

Quality of Service In Data Networks: Problems, Solutions, and Issues

**Raj Jain, Panel Chair
The Ohio State University
Columbus, OH 43210
Jain@CIS.Ohio-State.Edu**

These slides are available at

<http://www.cis.ohio-state.edu/~jain/talks/qos9905.htm>



- ❑ ATM QoS and Issues
- ❑ Integrated services/RSVP and Issues
- ❑ Differentiated Services and Issues
- ❑ QoS using MPLS
- ❑ End-to-end QoS
- ❑ This is an update to the May'98 talk
<http://www.cis.ohio-state.edu/~jain/talks/ipqos.htm>

QoS Triangle

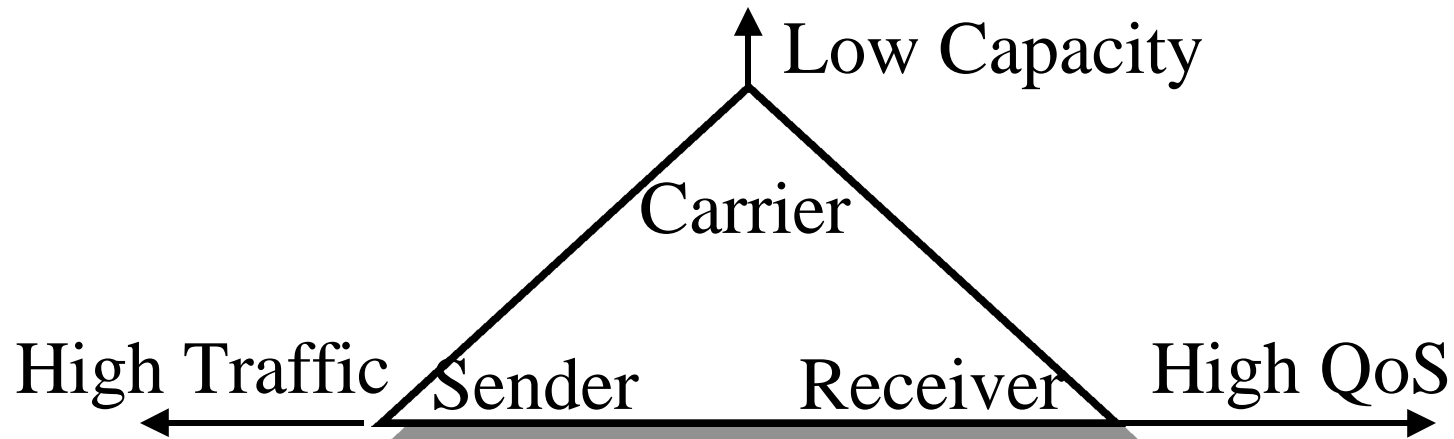

- ❑ Senders want to send traffic any time with high load, high burstiness
- ❑ Receivers expect low delay and high throughput
- ❑ Since links are expensive, providers want to minimize the infrastructure
- ❑ If one of the three gives in \Rightarrow no problem

What is QoS?

- ❑ "Unequal" allocation of resources
- ❑ Predictable Quality: Throughput, Delay, Loss, Delay jitter, Error rate
- ❑ Mechanisms: Routing, Classifiers, Scheduling, Queueing, Buffer Management, Admission Control, Shaping, Policing, capacity planning

ATM Service Categories

- ❑ **CBR**: Throughput, delay, delay variation
- ❑ **rt-VBR**: Throughput, delay, delay variation
- ❑ **nrt-VBR**: Throughput
- ❑ **UBR**: No Guarantees
- ❑ **GFR**: Minimum Throughput
- ❑ **ABR**: Minimum Throughput. Very low loss. Feedback.
- ❑ ATM also has QoS-based routing (PNNI)

Integrated Services

- ❑ Best Effort Service: Like UBR.
- ❑ Controlled-Load Service: Performance as good as in an unloaded datagram network. No quantitative assurances. Like nrt-VBR or UBR w MCR
- ❑ Guaranteed Service: rt-VBR
 - Firm bound on data throughput and delay.
 - Delay jitter or average delay not guaranteed or minimized.
 - Every element along the path must provide delay bound.
 - Is not always implementable, e.g., Shared Ethernet.
 - Like CBR or rt-VBR

RSVP

- ❑ Resource ReSerVation Protocol
- ❑ Internet signaling protocol
- ❑ Carries resource reservation requests through the network including traffic specs, QoS specs, network resource availability
- ❑ Sets up reservations at each hop

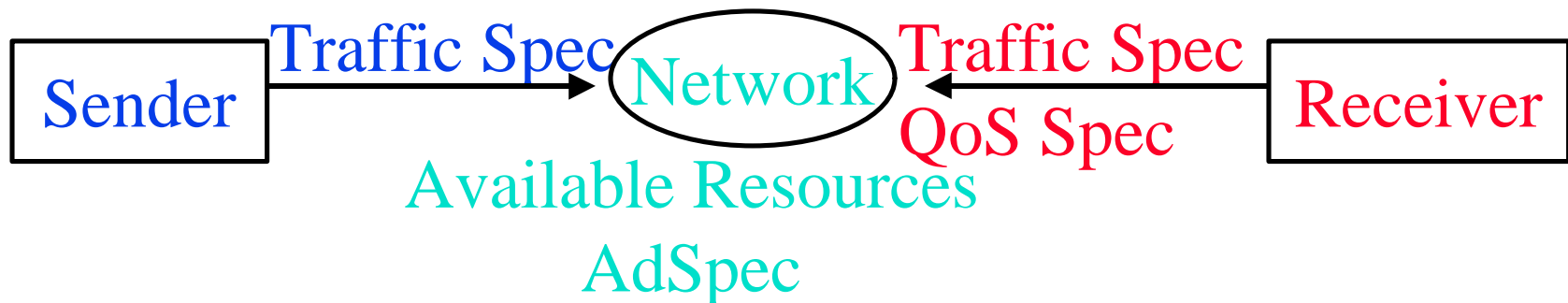

Differentiated Services

Ver	Hdr Len	Precedence	ToS	Unused	Tot Len
4b	4b	3b	4b	1b	16b

- ❑ IPv4: 3-bit precedence + 4-bit ToS
- ❑ OSPF and integrated IS-IS can compute paths for each ToS
- ❑ Many vendors use IP precedence bits but the service varies \Rightarrow Need a standard \Rightarrow Differentiated Services
- ❑ DS working group formed February 1998
- ❑ Charter: Define ds byte (IPv4 ToS field)
- ❑ Mail Archive: <http://www-nrg.ee.lbl.gov/diff-serv-arch/>

Multiprotocol Label Switching

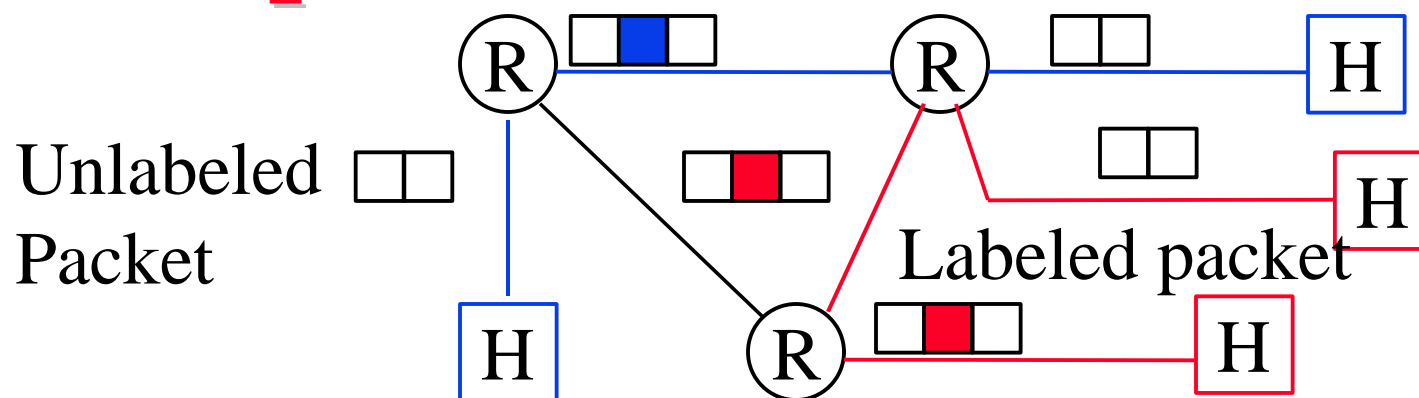

- ❑ Entry “label switch router (LSR)” attaches a label to the packet based on the route
- ❑ Other LSRs switch packets based on labels. Do not need to look inside \Rightarrow Fast.
- ❑ Labels have local significance \Rightarrow Different label at each hop (similar to VC #)
- ❑ Exit LSR strips off the label

Traffic Engineering Using MPLS

- ❑ Traffic Engineering = Performance Optimization
= Efficient resource allocation, Path splitting
⇒ Maximum throughput, Min delay, min loss
⇒ Quality of service
- ❑ In MPLS networks: “Traffic Trunks” = SVCs
Traffic trunks are routable entities like VCs
- ❑ Multiple trunks can be used in parallel to the same egress.
- ❑ Each traffic trunk can have a set of associated characteristics, e.g., priority, preemption, policing, overbooking

Bandwidth Broker

- ❑ Repository of policy database. Includes authentication
- ❑ Users request bandwidth from BB
- ❑ BB sends authorizations to leaf/border routers
Tells what to mark.
- ❑ Ideally, need to account for bandwidth usage along the path
- ❑ BB allocates only boundary or bottleneck

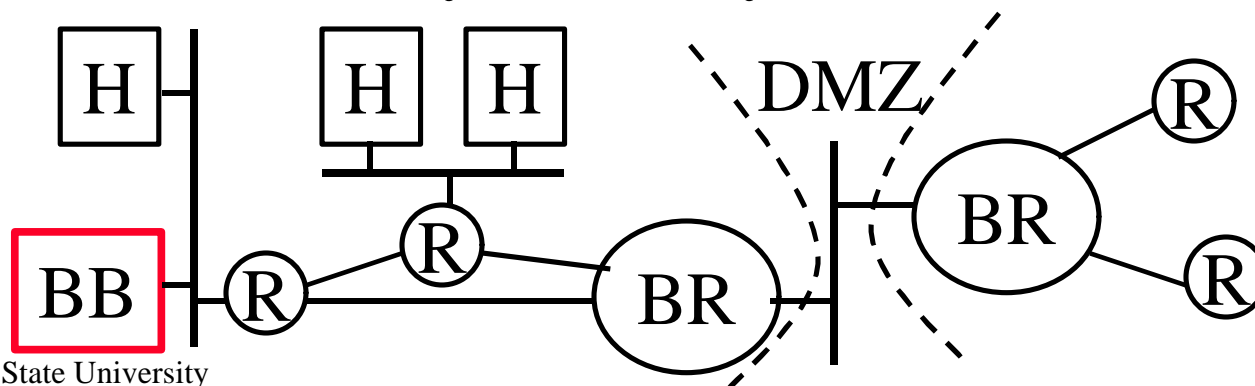

IEEE 802.1D Model

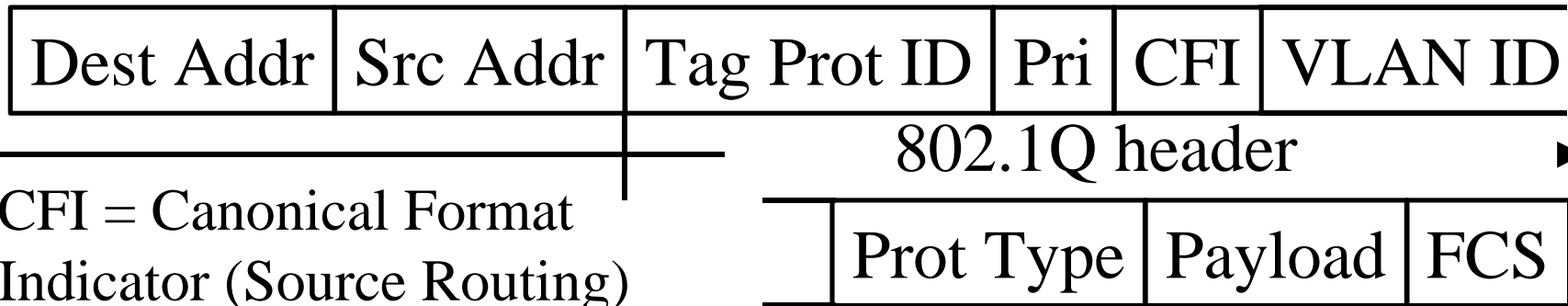

□ **Up to eight priorities:** Strict.

1 Background

2 Spare

0 Best Effort

3 Excellent Effort

4 Control load

5 Video (Less than 100 ms latency and jitter)

6 Voice (Less than 10 ms latency and jitter)

7 Network Control

End-to-end View

- ❑ ATM/PPP backbone, Switched LANs/PPP in Stub
- ❑ IntServ/RSVP, 802.1D, MPLS in Stub networks
- ❑ DiffServ, ATM, MPLS in the core

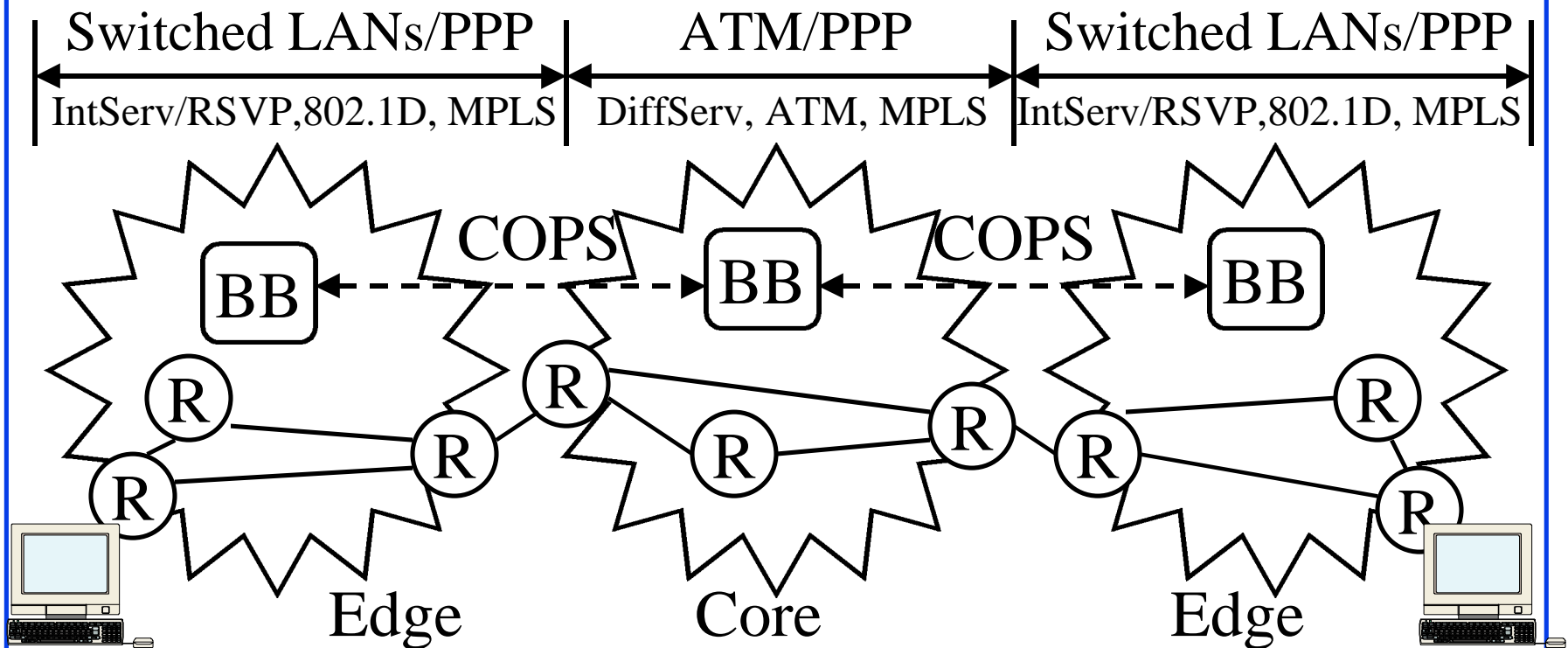

Summary

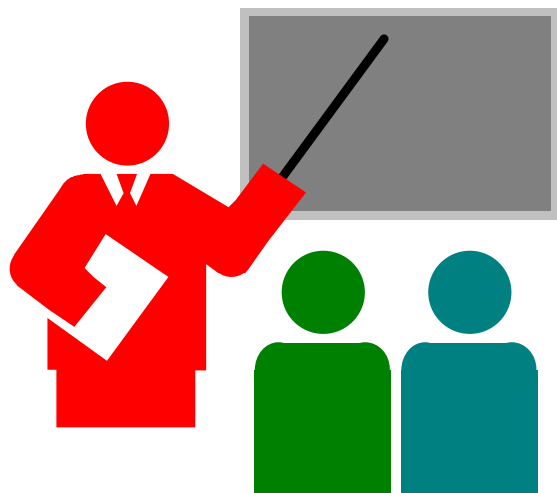

- ❑ ATM: CBR, VBR, ABR, UBR, GFR
- ❑ Integrated Services: GS = rtVBR, CLS = nrt-VBR
- ❑ Signaling protocol: RSVP
- ❑ Differentiated Services will use the DS byte
- ❑ MPLS allows traffic engineering
- ❑ 802.1D allows priority

References

- ❑ For a detailed list of references see:
refs/ipqs_ref.htm
- ❑ Additional papers and presentations on QoS are at:
<http://www.cis.ohio-state.edu/~jain/>

Our Panelists

- ❑ Sameh Rabie, Nortel Networks
- ❑ Sudhir Dixit, Nokia Research
- ❑ David Drury, FORE Systems
- ❑ Raj Yavatkar, Intel Corp

Thank You!

