

IEEE 802.21

Media Independent Handover (MIH)

Raj Jain
Professor of Computer Science and Engineering
Washington University in Saint Louis
Saint Louis, MO 63130

Audio/Video recordings of this lecture are available at:
<http://www.cse.wustl.edu/~jain/cse574-08/>



- Types of Handovers
- 802.21 Key Functions
- MIH Services
- MIHF Protocol
- Amendments for MIH

Types of Handovers

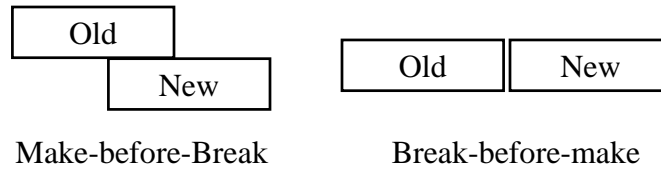

- Hard handover: Break-before-Make
- Soft handover: Make-before-Break. Need to use two radios
- Horizontal Handover: Same radio access technology (RAT)
- Vertical Handover: Different technologies
- Terminal Controlled
- Terminal Initiated, Network assisted
- Network Initiated, Network controlled

Washington University in St. Louis

CSE574S

©2008 Raj Jain

14-3

Intra-Technology Handovers

- 802.11i defines pre-authentication
- 802.11r is defining fast BSS transition
- 802.16e defines handover process optimization
- 802.1af is defining port access control (revised 802.1X)
- Most of these reduce handover time by pre-authentication with next target using current service

Washington University in St. Louis

CSE574S

©2008 Raj Jain

14-4

802.21 History and Timeline

- ❑ 1H2004: WG created
- ❑ 1H2005: Initial draft
- ❑ 2H2005: Changes to 802.11u, 802.16g, MIPSHOP
- ❑ 1H2006: WG letter ballot
- ❑ 2007: Sponsor ballot
- ❑ 2008: Standard
- ❑ 2009-10: Deployments

802.21 Key Functions

- ❑ Reduce power consumption by avoiding unnecessary scanning and using information. 802.16 module is turned on only if 802.16 is available.
- ❑ Reduce power consumption by using backend (core) network
- ❑ Reduce handover time by passing security/QoS information to next point of service
- ❑ Allow service providers to enforce their policies and roaming agreements

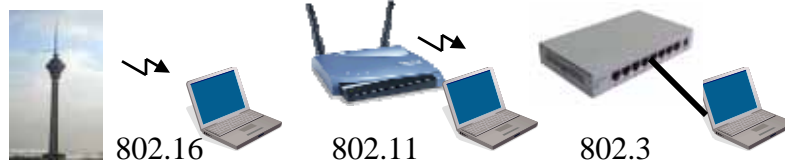

IEEE 802.21 Features

- ❑ Network Selection:
 - Allows users to select between 802.3, 802.11, 802.16, 3GPP, 3GPP2 networks
 - MS can automatically connect to the right network by observing user selections or by user policies
 - MS can notify user when available networks change or a switch occurs
- ❑ Session Continuity:
 - Allows make before break handovers
- ❑ Open Interface for:
 - Link state event reporting
 - Intersystem information service
 - Handover control (command) service

Washington University in St. Louis

CSE574S

©2008 Raj Jain

14-7

IEEE 802.21 Goals and Non-Goals

- ❑ Goals:
 - Architecture to enable low-latency handover across multiple technology access networks
 - Help in handover decision making
 - Standard functions to help gather network characteristics
 - Standard command procedures for seamless handovers
 - Supports both station initiated and network initiated handovers
- ❑ Non-Goals:
 - Define handover policies
 - Specify network selection procedure
 - Execute handover
 - Network detection procedure

Washington University in St. Louis

CSE574S

©2008 Raj Jain

14-8

802.21 Concepts

- ❑ Point of Access (PoA): Base Station or Access Point
- ❑ Mobile Node
- ❑ L2 Trigger: Layer 2 events
- ❑ Radio Access Technology (RAT): 802.11, 802.16, ...

MIH Services

- ❑ **Event Service:** Delivers triggers on events, e.g., link up, link down, new link available
- ❑ **Command Service:** Set of standard commands for handover control, e.g., Switch Link, Configure Link, Initiate handover, etc.
- ❑ **Information Service:** Defines a service that provides information for faster handovers, e.g., list of available networks, IP version, network operator, etc.
- ❑ MIH users access these services using well-defined service access points (SAPs)

Event Service

- ❑ Local (terminal side) and remote (network side) events are supported
- ❑ User preferences determine the delivery of events
- ❑ Events may trigger user actions

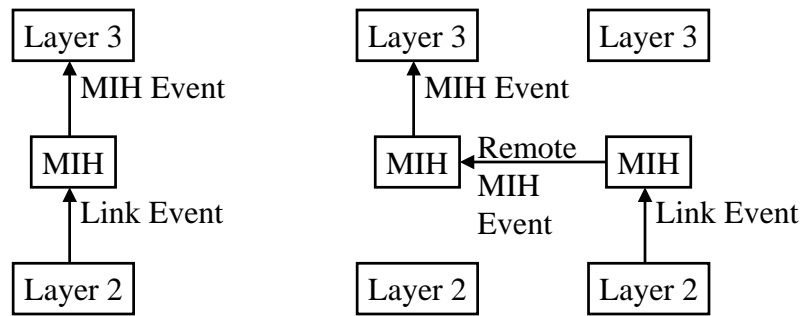

Washington University in St. Louis

CSE574S

©2008 Raj Jain

14-11

Triggers

- ❑ Link Layer Events
- ❑ Link up
- ❑ Link Down
- ❑ Link Going Down
- ❑ Link Detected (new link)
- ❑ Link Parameters Change (threshold crossing)
- ❑ Link Even Rollback
- ❑ Link SDU Transmit Status
- ❑ Link Handover Imminent
- ❑ Link Handover Complete

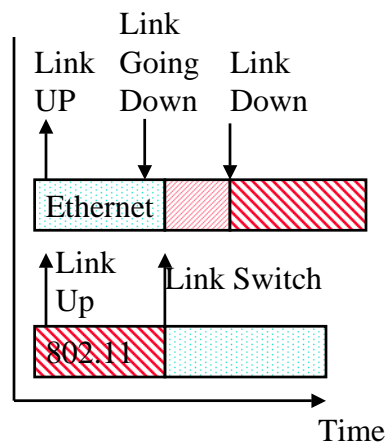

Washington University in St. Louis

CSE574S

©2008 Raj Jain

14-12

Command Service

- ❑ Commands flow from user to MIH and then to link layer
- ❑ Commands allow users to switch links
- ❑ User communicates separately with each technology
⇒ Commands do not flow from one technology to another

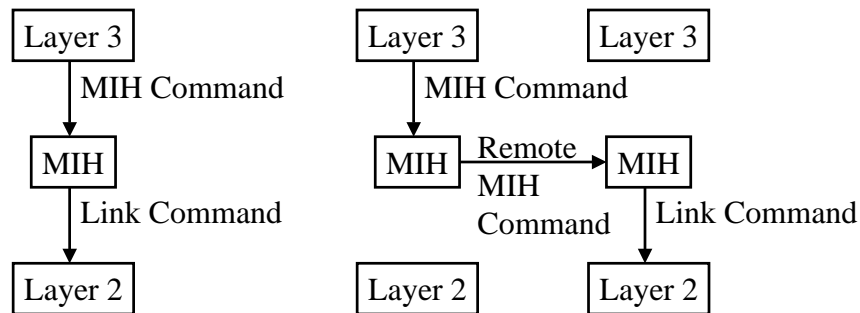

Washington University in St. Louis

CSE574S

©2008 Raj Jain

14-13

MIH Information Service

- ❑ Provides information about networks in a particular geographical area
- ❑ Information delivery via queries or by broadcast/multicast
- ❑ Generally static information
- ❑ 802.21 defines what information is required
- ❑ Does not define how the service is accessed

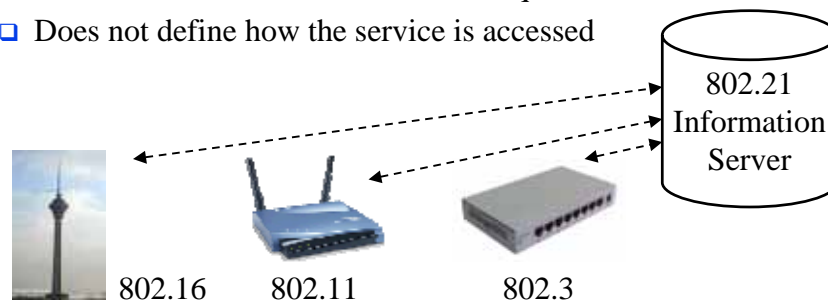

Washington University in St. Louis

CSE574S

©2008 Raj Jain

14-14

MIH Information Service (Cont)

- ❑ Common information representation
- ❑ List of available networks
- ❑ Location of POA
- ❑ Operator ID
- ❑ Roaming Partners
- ❑ Cost, Security, QoS
- ❑ Capabilities (emergency services, IMS)

MIH Services

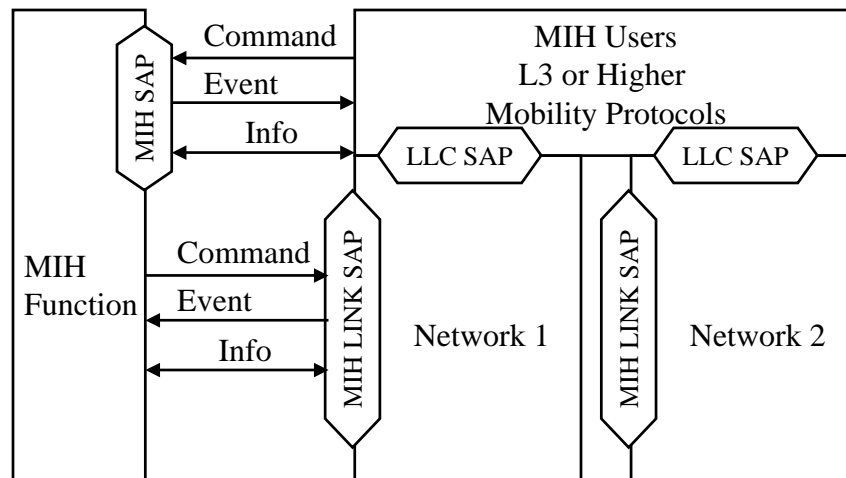

Network Initiated Handovers

- ❑ MIH Handover Initiate: Suggested PoA
- ❑ MIH Handover Prepare: current to target network
- ❑ MIH Handover Commit: Client commits to do handover
- ❑ MIH Handover complete: New network to old network. Send all buffered packets.

MIHF Protocol

- ❑ MIHF message sent between peer entities
- ❑ Communicates events, commands, and information
- ❑ MAC independent messages defined in 802.21
- ❑ Container for MIH messages for 802.11 defined in 802.11u
- ❑ Container for MIH messages for 802.16 defined in 802.16g
- ❑ Transport for MIH protocol defined in IETF MIPSHOP (Mobility for IP: Performance, Signaling, and Handoff Optimization)

802.21 Transport

- ❑ CS, ES, IS messages are transported over L2 or L3
- ❑ 802.11u is defining transport of 802.21 messages over 802.11
- ❑ MIPSHOP is defining transport over IP

802.11 Amendments for MIH

- ❑ MIH Capability indication in beacon
- ❑ MAC Layer Management Entity (MLME) Service Access Point (SAP): Link up indication, Scan confirm
- ❑ Information service for generic network selection: IS query frame
- ❑ Transport of MIHF protocol over 802.11

Summary

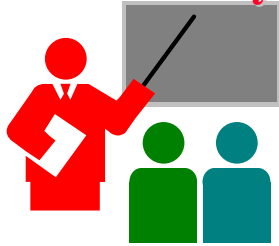

- ❑ 802.1 is a common protocol for handover initiation, network selection, handover
- ❑ 802.21 provides a common interface to L3 and higher mobility protocols
- ❑ Has triggers that allow higher layers to take action
- ❑ Has commands that allow higher layer to request action
- ❑ Has information service that allows all layers to not have to discover the static information

Washington University in St. Louis

CSE574S

©2008 Raj Jain

14-21

IEEE 802.21 References

- ❑ IEEE P802.21/D9.1, "Draft Standard for Local and Metropolitan Area Networks: Media Independent Handover Services," Mar 2008, 300 pp. (Available only to working group members)
- ❑ V. Gupta, et al, "IEEE 802.21 Media Independent Handover: Tutorial," Jul 2006, 65 pp.,
http://www.ieee802.org/802_tutorials/july06/802%2021-IEEE-Tutorial.ppt
- ❑ Stefano M. Faccin, "IEEE 802.21 Media Independent Handoff: Overview of services and scenarios for 3GPP2," Liaison to 3GPP2, Jul 2005, 31 pp.,
http://www.3gcn.org/3gpp2/TSGS/Working/_2005/2005-10-Beijing/Plenary/S00-20051024-041A_21-05-0396-03-0000-AdHoc3GPP2LiasionPackage.pdf

Washington University in St. Louis

CSE574S

©2008 Raj Jain

14-22

IEEE 802.21 References (Cont)

- ❑ Y. Ohba, et al, "Media-Independent Handover Security Tutorial," IEEE 802 meeting, March 17, 2008, 36 pp., http://ieee802.org/802_tutorials/march08/21-08-0080-01-0sec-security-signaling-during-handovers-tutorial.ppt
- ❑ Peretz Feder, "802.21 Liaison - Session #52 Closing Plenary," IEEE 802.16, 8 pp., http://wirelessman.org/liaison/docs/L80216-05_061.pdf

Homework 14

- ❑ Read the IEEE 802.21 standard. Make a diagram showing general MIHF reference model showing the exchange of MIH information and messages with the remote MIHF.