

Operational Laws



Raj Jain
Washington University in Saint Louis
Saint Louis, MO 63130
Jain@cse.wustl.edu

Audio/Video recordings of this lecture are available at:

<http://www.cse.wustl.edu/~jain/cse567-08/>

Washington University in St. Louis

CSE567M

©2008 Raj Jain

33-1



- What is an Operational Law?
 1. Utilization Law
 2. Forced Flow Law
 3. Little's Law
 4. General Response Time Law
 5. Interactive Response Time Law
 6. Bottleneck Analysis

Washington University in St. Louis

CSE567M

©2008 Raj Jain

33-2

Operational Laws

- ❑ Relationships that do not require any assumptions about the distribution of service times or inter-arrival times.
- ❑ Identified originally by Buzen (1976) and later extended by Denning and Buzen (1978).
- ❑ **Operational** \Rightarrow Directly measured.
- ❑ **Operationally testable assumptions**
 - \Rightarrow assumptions that can be verified by measurements.
 - For example, whether number of arrivals is equal to the number of completions?
 - This assumption, called job flow balance, is operationally testable.
 - A set of observed service times is or is not a sequence of independent random variables is or is not operationally testable.

Washington University in St. Louis

CSE567M

©2008 Raj Jain

33-3

Operational Quantities

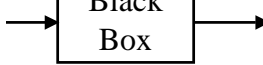
- ❑ Quantities that can be directly measured during a finite observation period. 

- ❑ T = Observation interval A_i = number of arrivals
- ❑ C_i = number of completions B_i = busy time B_i

$$\text{Arrival Rate } \lambda_i = \frac{\text{Number of arrivals}}{\text{Time}} = \frac{A_i}{T}$$

$$\text{Throughput } X_i = \frac{\text{Number of completions}}{\text{Time}} = \frac{C_i}{T}$$

$$\text{Utilization } U_i = \frac{\text{Busy Time}}{\text{Total Time}} = \frac{B_i}{T}$$

$$\text{Mean service time } S_i = \frac{\text{Total time Served}}{\text{Number served}} = \frac{B_i}{C_i}$$

Washington University in St. Louis

CSE567M

©2008 Raj Jain

33-4

Utilization Law

$$\begin{aligned} \text{Utilization } U_i &= \frac{\text{Busy Time}}{\text{Total Time}} = \frac{B_i}{T} \\ &= \frac{C_i}{T} \times \frac{B_i}{C_i} = \frac{\text{Completions}}{\text{Time}} \times \frac{\text{Busy Time}}{\text{Completions}} \\ &= \text{Throughput} \times \text{Mean Service Time} = X_i S_i \end{aligned}$$

- This is one of the operational laws
- Operational laws are similar to the elementary laws of motion
For example,

$$d = \frac{1}{2}at^2$$

- Notice that distance d , acceleration a , and time t are **operational quantities**. No need to consider them as expected values of random variables or to assume a distribution.

Example 33.1

- Consider a network gateway at which the packets arrive at a rate of 125 packets per second and the gateway takes an average of two milliseconds to forward them.
- Throughput $X_i =$ Exit rate = Arrival rate = 125 packets/second
- Service time $S_i = 0.002$ second
- Utilization $U_i = X_i S_i = 125 \times 0.002 = 0.25 = 25\%$
- This result is valid for any arrival or service process.
Even if inter-arrival times and service times are not IID random variables with exponential distribution.

Forced Flow Law

- ❑ Relates the system throughput to individual device throughputs.
- ❑ In an open model,
System throughput = # of jobs leaving the system per unit time
- ❑ In a closed model, System throughput = # of jobs traversing OUT to IN link per unit time.
- ❑ If observation period T is such that $A_i = C_i$
⇒ Device satisfies the assumption of *job flow balance*.
- ❑ Each job makes V_i requests for i th device in the system
- ❑ $C_i = C_0 V_i$ or $V_i = C_i / C_0$ is called visit ratio

Forced Flow Law (Cont)

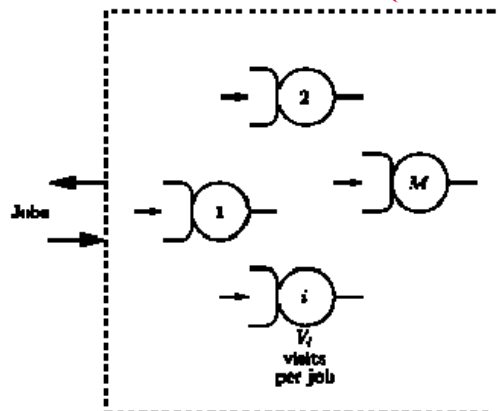

- ❑ System throughput:

$$\text{System throughput } X = \frac{\text{Jobs completed}}{\text{Total time}} = \frac{C_0}{T}$$

Forced Flow Law (Cont)

- Throughput of i^{th} device:

$$\text{Device Throughput } X_i = \frac{C_i}{T} = \frac{C_i}{C_0} \times \frac{C_0}{T}$$

- In other words:

$$X_i = X V_i$$

- This is the **forced flow law**.

Bottleneck Device

- Combining the forced flow law and the utilization law, we get:

$$\begin{aligned} \text{Utilization of } i^{\text{th}} \text{ device } U_i &= X_i S_i \\ &= X V_i S_i \\ U_i &= X D_i \end{aligned}$$

- Here $D_i = V_i S_i$ is the total service demand on the device for all visits of a job.
- The device with the highest D_i has the highest utilization and is the **bottleneck device**.

Example 33.2

- In a timesharing system, accounting log data produced the following profile for user programs.
 - Each program requires five seconds of CPU time, makes 80 I/O requests to the disk A and 100 I/O requests to disk B.
 - Average think-time of the users was 18 seconds.
 - From the device specifications, it was determined that disk A takes 50 milliseconds to satisfy an I/O request and the disk B takes 30 milliseconds per request.
 - With 17 active terminals, disk A throughput was observed to be 15.70 I/O requests per second.
- We want to find the system throughput and device utilizations.

Example 33.2 (Cont)

$$\begin{aligned}
 D_{CPU} &= 5 \text{ seconds,} \\
 V_A &= 80, \\
 V_B &= 100, \\
 Z &= 18 \text{ seconds,} \\
 S_A &= 0.050 \text{ seconds,} \\
 S_B &= 0.030 \text{ seconds,} \\
 N &= 17, \text{ and} \\
 X_A &= 15.70 \text{ jobs/second}
 \end{aligned}$$

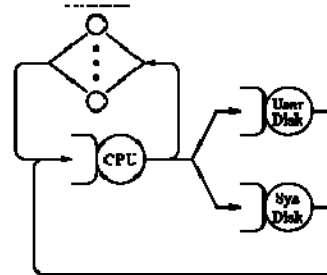

- Since the jobs must visit the CPU before going to the disks or terminals, the CPU visit ratio is:

$$\begin{aligned}
 V_{CPU} &= V_A + V_B + 1 = 181 \\
 D_{CPU} &= 5 \text{ seconds} \\
 D_A &= S_A V_A = 0.050 \times 80 = 4 \text{ seconds} \\
 D_B &= S_B V_B = 0.030 \times 100 = 3 \text{ seconds}
 \end{aligned}$$

Example 33.2 (Cont)

- Using the forced flow law, the throughputs are:

$$\begin{aligned}X &= \frac{X_A}{V_A} = \frac{15.70}{80} = 0.1963 \text{ jobs/second} \\X_{CPU} &= XV_{CPU} = 0.1963 \times 181 \\&= 35.48 \text{ requests/second} \\X_B &= XV_B = 0.1963 \times 100 \\&= 19.6 \text{ requests/second}\end{aligned}$$

- Using the utilization law, the device utilizations are:

$$\begin{aligned}U_{CPU} &= XD_{CPU} = 0.1963 \times 5 = 98\% \\U_A &= XD_A = 0.1963 \times 4 = 78.4\% \\U_B &= XD_B = 0.1963 \times 3 = 58.8\%\end{aligned}$$

Washington University in St. Louis

CSE567M

©2008 Raj Jain

33-13

Transition Probabilities

- p_{ij} = Probability of a job moving to j^{th} queue after service completion at i^{th} queue
- Visit ratios and transition probabilities are equivalent in the sense that given one we can always find the other.
- In a system with job flow balance: $C_j = \sum_{i=0}^M C_i p_{ij}$
 $i = 0 \Rightarrow$ visits to the outside link
- p_{i0} = Probability of a job exiting from the system after completion of service at i^{th} device
- Dividing by C_0 we get: $V_j = \sum_{i=0}^M V_i p_{ij}$

Washington University in St. Louis

CSE567M

©2008 Raj Jain

33-14

Transition Probabilities (Cont)

- Since each visit to the outside link is defined as the completion of the job, we have: $V_0 = 1$
- These are called **visit ratio equations**
- In central server models, after completion of service at every queue, the jobs always move back to the CPU queue:

$$p_{i1} = 1 \quad \forall i \neq 1$$

$$p_{ij} = 0 \quad \forall i, j \neq 1$$

Transition Probabilities (Cont)

- The above probabilities apply to exit and entrances from the system ($i=0$), also. Therefore, the visit ratio equations become:

$$1 = V_1 p_{10}$$

$$V_1 = 1 + V_2 + V_3 + \dots + V_M$$

$$V_j = V_1 p_{1j} = \frac{p_{1j}}{p_{10}} \quad j = 2, 3, \dots, M$$

- Thus, we can find the visit ratios by dividing the probability p_{1j} of moving to j^{th} queue from CPU by the exit probability p_{10} .

Example 33.3

- Consider the queueing network:

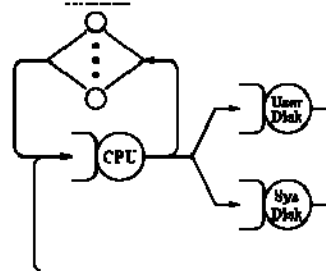

- The visit ratios are $V_A=80$, $V_B=100$, and $V_{CPU}=181$.
- After completion of service at the CPU the probabilities of the job moving to disk A, disk B, or terminals are $80/181$, $100/181$, and $1/181$, respectively. Thus, the transition probabilities are 0.4420 , 0.5525 , and 0.005525 .

Example 33.3 (Cont)

- Given the transition probabilities, we can find the visit ratios by dividing these probabilities by the exit probability (0.005525):

$$\begin{aligned}V_A &= \frac{0.4420}{0.005525} = 80 \\V_B &= \frac{0.5525}{0.005525} = 100 \\V_{CPU} &= 1 + V_A + V_B = 1 + 80 + 100 = 181\end{aligned}$$

Little's Law

Mean number in the device
= Arrival rate \times Mean time in the device
 $Q_i = \lambda_i R_i$

- If the job flow is balanced, the arrival rate is equal to the throughput and we can write:

$$Q_i = X_i R_i$$

Example 33.4

- The average queue length in the computer system of Example 33.2 was observed to be: 8.88, 3.19, and 1.40 jobs at the CPU, disk A, and disk B, respectively. What were the response times of these devices?
- In Example 33.2, the device throughputs were determined to be:

$$X_{CPU} = 35.48, X_A = 15.70, \text{ and } X_B = 19.6$$

- The new information given in this example is:

$$Q_{CPU} = 8.88, Q_A = 3.19, \text{ and } Q_B = 1.40$$

Example 33.4 (Cont)

- Using Little's law, the device response times are:

$$R_{CPU} = Q_{CPU}/X_{CPU} = 8.88/35.48 = 0.250 \text{ seconds}$$

$$R_A = Q_A/X_A = 3.19/15.70 = 0.203 \text{ seconds}$$

$$R_B = Q_B/X_B = 1.40/19.6 = 0.071 \text{ seconds}$$

General Response Time Law

- There is one terminal per user and the rest of the system is shared by all users.
- Applying Little's law to the central subsystem:
- $Q = X R$
- Here,
- Q = Total number of jobs in the system
- R = system response time
- X = system throughput

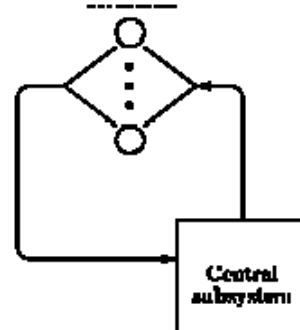

$$Q = Q_1 + Q_2 + \cdots + Q_M$$

$$X R = X_1 R_1 + X_2 R_2 + \cdots + X_M R_M$$

General Response Time Law (Cont)

- Dividing both sides by X and using forced flow law:

$$R = V_1 R_1 + V_2 R_2 + \cdots + V_M R_M$$

- or,

$$R = \sum_{i=1}^M R_i V_i$$

- This is called the **general response time law**.
- This law holds even if the job flow is not balanced.

Example 33.5

- Let us compute the response time for the timesharing system of Examples 33.2 and 33.4
- For this system:

$$V_{CPU} = 181, V_A = 80, \text{ and } V_B = 100$$

$$R_{CPU} = 0.250, R_A = 0.203, \text{ and } R_B = 0.071$$

- The system response time is:

$$\begin{aligned} R &= R_{CPU} V_{CPU} + R_A V_A + R_B V_B \\ &= 0.250 \times 181 + 0.203 \times 80 + 0.071 \times 100 \\ &= 68.6 \end{aligned}$$

- The system response time is 68.6 seconds.

Interactive Response Time Law

- If $Z =$ think-time, $R =$ Response time
 - The total cycle time of requests is $R+Z$
 - Each user generates about $T/(R+Z)$ requests in T

- If there are N users:

$$\begin{aligned}\text{System throughput } X &= \text{Total \# of requests/Total time} \\ &= N(T/(R+Z))/T \\ &= N/(R+Z)\end{aligned}$$

or

$$R = (N/X) - Z$$

- This is the interactive response time law

Example 33.6

- For the timesharing system of Example 33.2, we can compute the response time using the interactive response time law as follows:

- Therefore:

$$X = 0.1963, N = 17, \text{ and } Z = 18$$

$$R = \frac{N}{X} - Z = \frac{17}{0.1963} - 18 = 86.6 - 18 = 68.6 \text{ seconds}$$

- This is the same as that obtained earlier in Example 33.5.

Bottleneck Analysis

- From forced flow law:

$$U_i \propto D_i$$

- The device with the highest total service demand D_i has the highest utilization and is called the bottleneck device.
- Note: Delay centers can have utilizations more than one without any stability problems. Therefore, delay centers cannot be a bottleneck device.
- Only queueing centers used in computing D_{max} .
- The bottleneck device is the key limiting factor in achieving higher throughput.

Bottleneck Analysis (Cont)

- Improving the bottleneck device will provide the highest payoff in terms of system throughput.
- Improving other devices will have little effect on the system performance.
- Identifying the bottleneck device should be the first step in any performance improvement project.

Bottleneck Analysis (Cont)

- Throughput and response times of the system are bound as follows:

$$X(N) \leq \min\left\{\frac{1}{D_{max}}, \frac{N}{D + Z}\right\}$$

and

$$R(N) \geq \max\{D, ND_{max} - Z\}$$

- Here, $D = \sum D_i$ is the sum of total service demands on all devices except terminals.
- These are known as asymptotic bounds

Bottleneck Analysis: Proof

- The asymptotic bounds are based on the following observations:
- The utilization of any device cannot exceed one. This puts a limit on the maximum obtainable throughput.
- The response time of the system with N users cannot be less than a system with just one user. This puts a limit on the minimum response time.

Proof (Cont)

- The interactive response time formula can be used to convert the bound on throughput to that on response time and vice versa.

- For the bottleneck device b we have:

$$U_b = X D_{max}$$

- Since U_b cannot be more than one, we have:

$$X D_{max} \leq 1$$

$$X \leq \frac{1}{D_{max}}$$

Proof (Cont)

- With just one job in the system, there is no queueing and the system response time is simply the sum of the service demands:

$$R(1) = D_1 + D_2 + \cdots + D_M = D$$

- Here, D is defined as the sum of all service demands.
- With more than one user there may be some queueing and so the response time will be higher. That is:

Proof (Cont)

- Applying the interactive response time law to the bounds:

$$R(N) \geq D$$

- Combining these bounds we get the asymptotic bounds.

$$R(N) = \frac{N}{X(N)} - Z \geq ND_{max} - Z$$

$$X(N) = \frac{N}{R(N) + Z} \leq \frac{N}{D + Z}$$

Typical Asymptotic Bounds

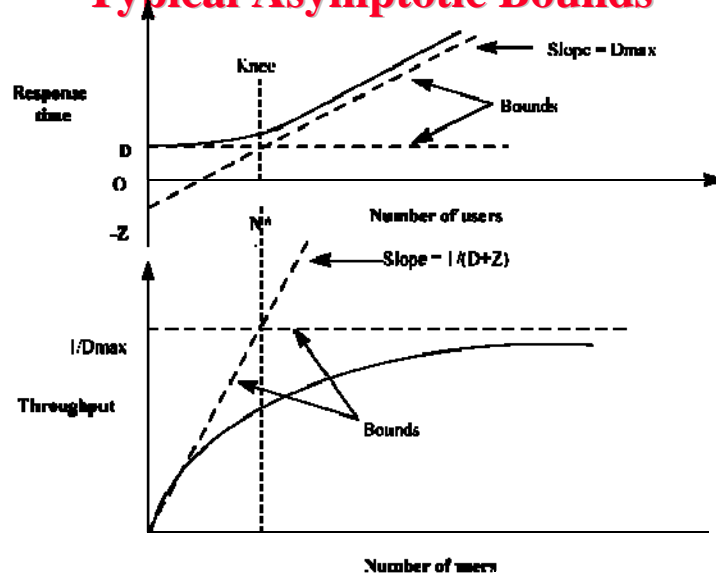

Typical Asymptotic Bounds (Cont)

- The number of jobs N^* at the knee is given by:

$$D = N^* D_{max} - Z$$

$$N^* = \frac{D + Z}{D_{max}}$$

- If the number of jobs is more than N^* , then we can say with certainty that there is queueing somewhere in the system.
- The asymptotic bounds can be easily explained to people who do not have any background in queueing theory or performance analysis.

Example 33.7

- For the timesharing system considered in Example 33.2:

$$D_{CPU} = 5, D_A = 4, D_B = 3, Z = 18$$

$$D = D_{CPU} + D_A + D_B = 5 + 4 + 3 = 12$$

$$D_{max} = D_{CPU} = 5$$

- The asymptotic bounds are:

$$X(N) \leq \min \left\{ \frac{N}{D + Z}, \frac{1}{D_{max}} \right\} = \min \left\{ \frac{N}{30}, \frac{1}{5} \right\}$$

$$R(N) \geq \max \{ D, N D_{max} - Z \} = \max \{ 12, 5N - 18 \}$$

Example 33.7: Asymptotic Bounds

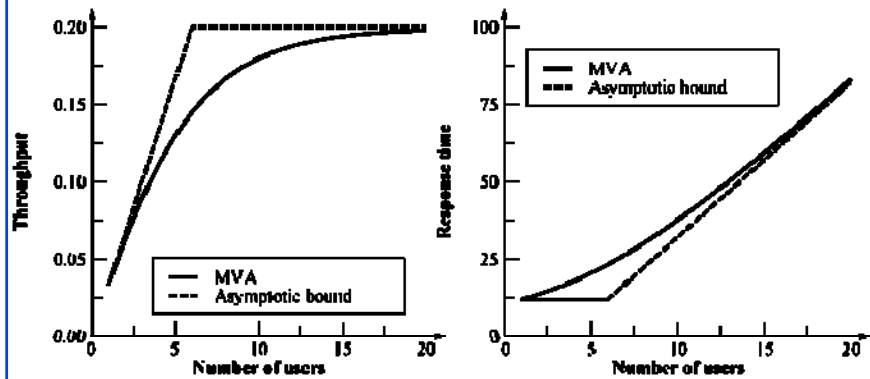

Washington University in St. Louis

CSE567M

©2008 Raj Jain

33-37

Example 33.7 (Cont)

- The knee occurs at:

$$12 = 5N^* - 18$$

or

$$N^* = \frac{12 + 18}{5} = \frac{30}{5} = 6$$

- Thus, if there are more than 6 users on the system, there will certainly be queueing in the system.

Washington University in St. Louis

CSE567M

©2008 Raj Jain

33-38

Example 33.8

- How many terminals can be supported on the timesharing system of Example 33.2 if the response time has to be kept below 100 seconds?

- Using the asymptotic bounds on the response time we get:

$$R(N) \geq \max\{12, 5N - 18\}$$

- The response time will be more than 100, if: $5N - 18 \geq 100$

- That is, if: $N \geq 23.6$

- the response time is bound to be more than 100. Thus, the system cannot support more than 23 users if a response time of less than 100 is required.

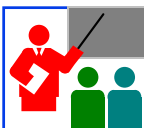

Summary

Utilization Law:	$U_i = X_i S_i = X D_i$
Forced Flow Law:	$X_i = X V_i$
Little's Law:	$Q_i = X_i R_i$
General Response Time Law:	$R = \sum_{i=1}^M R_i V_i$
Interactive Response Time Law:	$R = \frac{D}{X} - Z$
Asymptotic Bounds:	$R \geq \max\{D, N D_{max} - Z\}$
	$X \leq \min\{1/D_{max}, N/(D + Z)\}$

- Symbols:

D	= Sum of service demands on all devices = $\sum_i D_i$
D_i	= Total service demand per job for i th device = $S_i V_i$
D_{max}	= Service demand on the bottleneck device = $\max_i \{D_i\}$
N	= Number of jobs in the system
Q_i	= Number in the i th device
R	= System response time
R_i	= Response time per visit to the i th device
S_i	= Service time per visit to the i th device
U_i	= Utilization of i th device
V_i	= Number of visits per job to the i th device
X	= System throughput
X_i	= Throughput of the i th device
Z	= Think time

Homework 33

For a timesharing system with two disks (user and system), the probabilities for jobs completing the service at the CPU were found to be **0.75** to disk A, **0.15** to disk B, and **0.1** to the terminals. The user think time was measured to be 5 seconds, the disk service times are 30 milliseconds and 25 milliseconds, while the average service time per visit to the CPU was 40 milliseconds.

Using the queueing network model shown in Figure 32.8 answer the following for this system:

- a. For each job, what are the visit ratios for CPU, disk A, and disk B?
- b. For each device, what is the total service demand?
- c. If disk A utilization is **50%**, what is the utilization of the CPU and disk B?

Homework (Cont)

- d. If the utilization of disk B is 8%, what is the average response time when there are 20 users on the system?
- e. What is the bottleneck device?
- f. What is the minimum average response time?
- g. What is the maximum possible disk A utilization for this configuration?
- h. What is the maximum possible throughput of this system?
- i. What changes in CPU speed would you recommend to achieve a response time of ten seconds with **30** users? Would you also need a faster disk A or disk B?
- j. Write the expressions for asymptotic bounds on throughput and response time.

Homework (Cont)

For this system which device would be the bottleneck if:

- k. The CPU is replaced by another unit that is twice as fast?
- l. disk A is replaced by another unit that is twice as slow?
- m. disk B is replaced by another unit that is twice as slow?
- n. The memory size is reduced so that the jobs make **25** times more visits to disk B due to increased page faults?