Optical DWDM Networks

Raj Jain

The Ohio State University

Columbus, OH 43210

Jain@CIS.Ohio-State.Edu

These slides are available at

<http://www.cis.ohio-state.edu/~jain/cis788-99/>



Sparse and Dense WDM

Recent WDM Records

WDM Applications and Sample Products

Key Technologies

Types of Fibers

Amplifiers

Upcoming Technologies

Sparse and Dense WDM

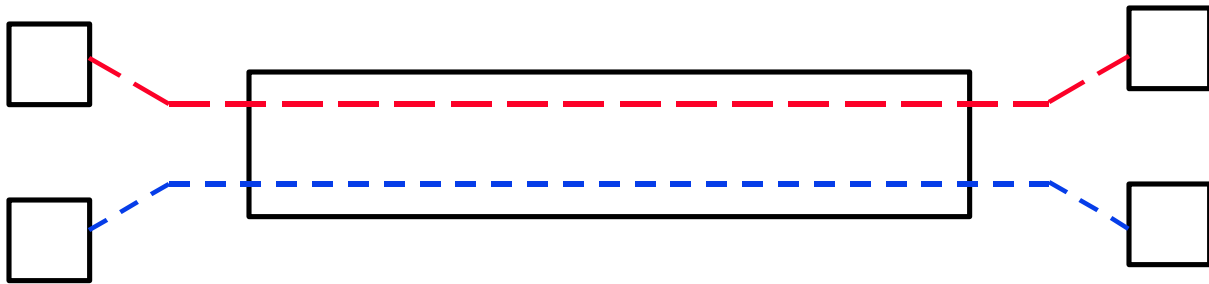

10Base-F uses 850 nm

100Base-FX uses 1310 nm

Some telecommunication lines use 1550 nm

WDM: 850nm + 1310nm or 1310nm + 1550nm

Dense \Rightarrow Closely spaced \approx 1nm separation

Recent WDM Records

10 Gbps over a single wavelength upto 65 km demonstrated by Alcatel in Summer of 1998. Modulation gave 20 GHz at 3-dB point. The distance limitation was due to PMD.

2.64 Tbps to 120km (NEC'96): $132 \lambda \times 20$ Gbps

1.4 Tbps 600 km (NTT'97): $70 \lambda \times 20$ Gbps

1 Tbps 400 km (Lucent 97): $100 \lambda \times 10$ Gbps using TrueWave Fiber

320 Gbps 7200 km (Lucent 97): $64 \lambda \times 5$ Gbps

WDM Applications

WANs: Fiber links \Rightarrow WDM \Rightarrow DWDM Links

Undersea Links: Amplifiers \Rightarrow High maintenance cost
 \Rightarrow Can't put too many fibers

DWDM highly successful in long-haul market.

Not yet cost-competitive in metro market.

Bandwidth demand is low and more dynamic.

Sample Products

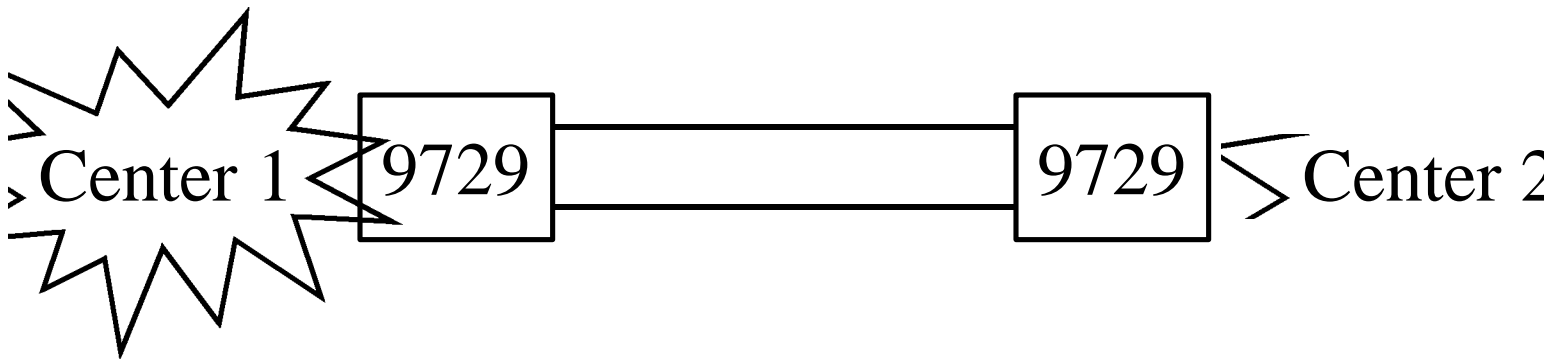

[1994: IBM 9729. First commercial system.

Allows 10 full-duplex channels in one fiber upto 50 kms. Designed to connect large mainframe datacenters.

Channel spacing is 1 nm

Distance limited to 50km to avoid amplifiers.

Products (Cont)

Lucent's WaveStar product allows 400 Gbps over a single fiber using 80 channel DWDM (January 1998)

Lucent's LazrSPEED allows 10 Gb/s up to 300 on LazrSPEED multimode fibers using low cost short-wavelength (850nm) vertical cavity surface-emitting laser (VCSEL) transceivers. Demoed at May 99 Interop.

Monterey make wavelength routers that allow mesh architecture and use OSPF or PNNI like routing.

Key Technologies

Tunable Lasers

Fast tuning receivers

Frequency converters

Amplifiers

Splitters, Combiners

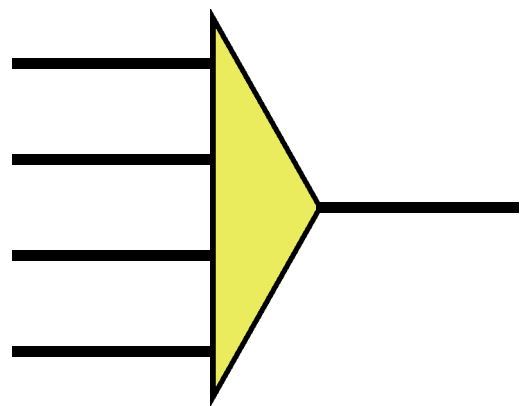
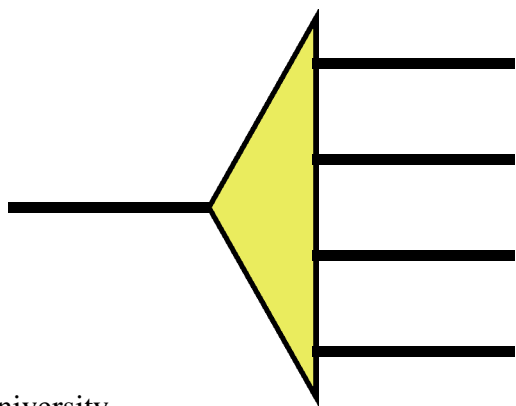

Directional Couplers

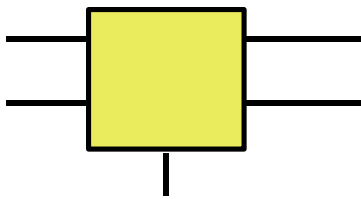

Control

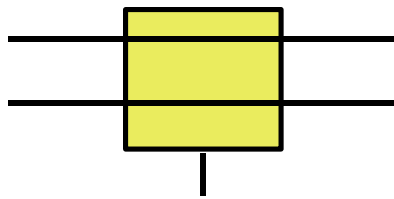

Control

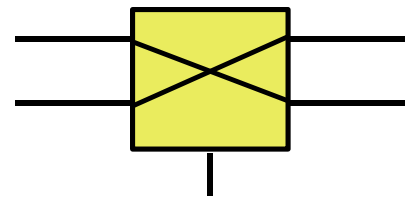

Control

Can be used in bus networks:

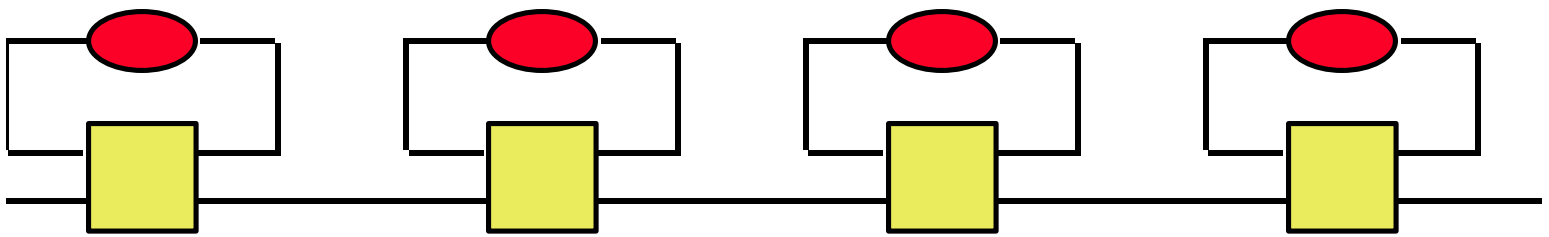

Larger switches can be built out of 2×2 switches

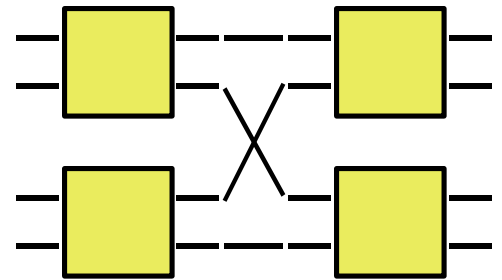

Types of Fibers

Multimode Fiber: Core Diameter 50 or 62.5 μm
Wide core \Rightarrow Several rays (mode) enter the fiber
Each mode travels a different distance

Single Mode Fiber: 10- μm core. Lower dispersion.

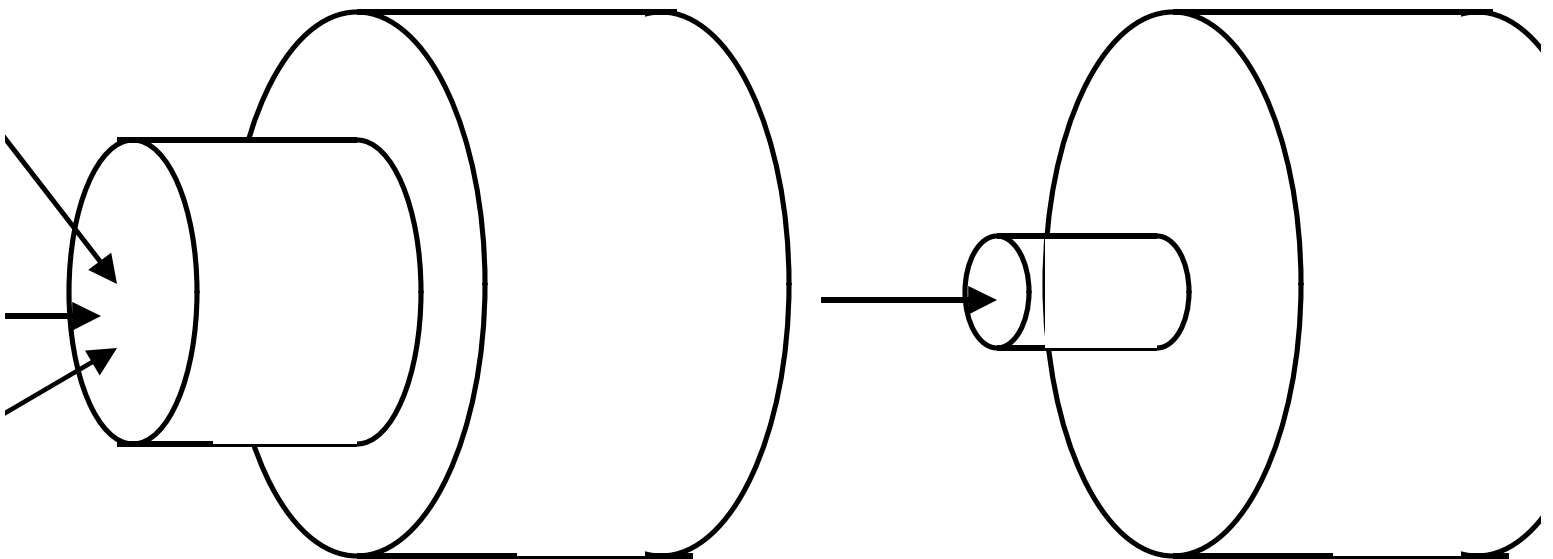

Dispersion Shifted Fiber

Zero dispersion at 1310nm

1550 nm has a lower attenuation

EDFAs operate at 1550 nm \Rightarrow DWDM systems at 1550 nm

Special core profile \Rightarrow zero dispersion at 1550 nm

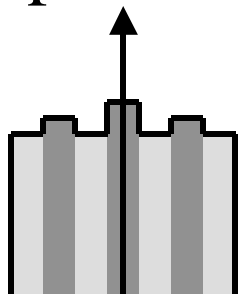

Dispersion shifted

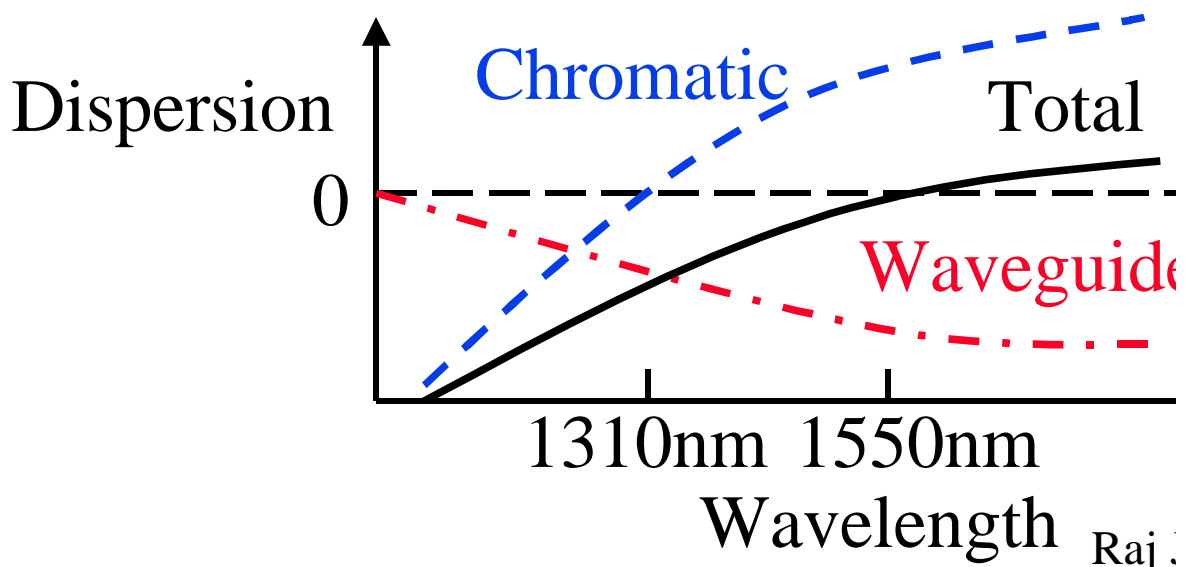

Dispersion Flattened Fiber

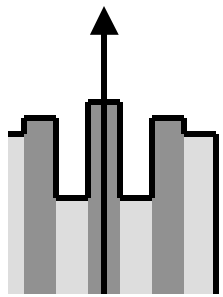

Dispersion
flattened

Dispersion

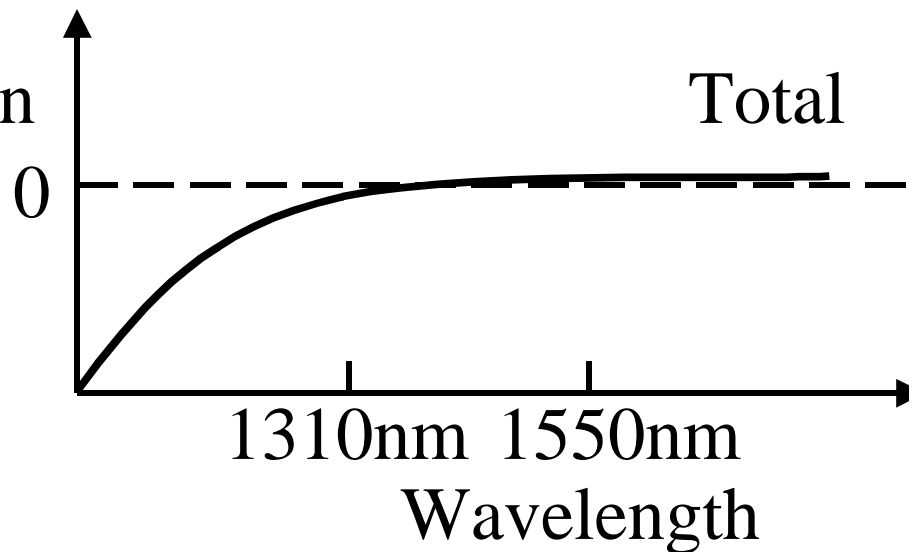

Less than 3 ps/nm/km over 1300-1700 nm

Use 1300 nm now and 1550 in future

Low dispersion causes four-way mixing

⇒ DSF/DFB not used in DWDM systems

Four-way Mixing (FWM)

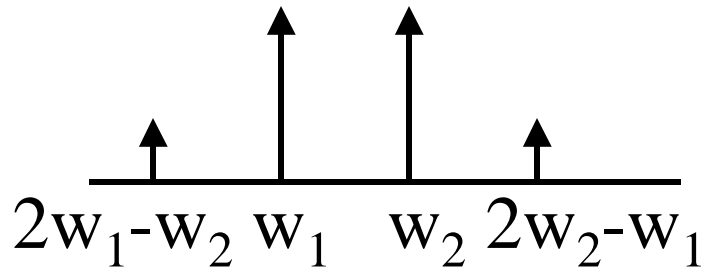

Caused when multiple wavelengths travel in the same phase for long time

New signals are generated at the same frequency spacing as original: $w_1, w_2 \Rightarrow 2w_2 - w_1, 2w_1 - w_2$

Closer channels \Rightarrow More FWM

More power \Rightarrow More FWM

Less dispersion \Rightarrow More time same phase
 \Rightarrow More FWM

Dispersion Optimized Fiber

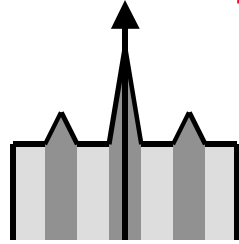

Non-zero dispersion shifted fiber (NZ-DSF)
⇒ 4 ps/nm/km near 1530-1570nm band

Avoids four-way mixing

Different vendors have different characteristics:

Tru-Wave from Lucent. SFM-LS from Corning

Dispersion shifting reduces the effective area of core

⇒ increases power density ⇒ More non-linearity

Large effective area fibers (LEAF) from Corning:

DOF with larger effective area

Dispersion Compensating Fiber

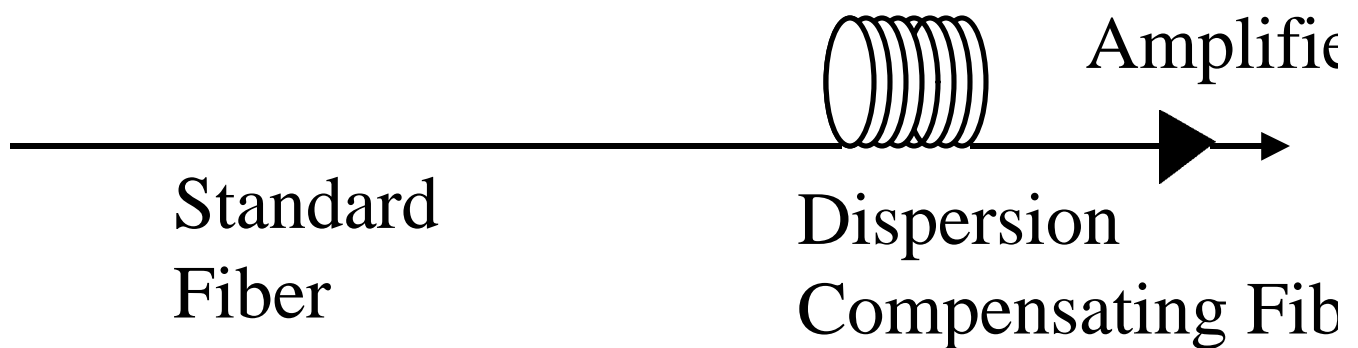

Standard fiber has 17 ps/nm/km

DCF has -100 ps/nm/km

100 km of standard fiber followed by 17 km of DCF
⇒ zero dispersion

DCF has much narrower core ⇒ More attenuation and non-linearity ⇒ Need to amplify

Polarization Mode Dispersion

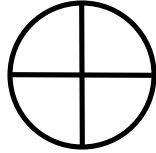

Each light pulse consists of two orthogonally polarized pulses.

These polarizations experience different delays through the fiber.

Polarization Mode Dispersion (PMD) limits distance to square of the bit rate

⇒ OC-192 to 1/16th of OC-48, OC-768 to 1/256th.

Need Regenerators to compensate for PMD

⇒ Expensive

⇒ Most DWDM systems operate at OC-48

Plastic Fiber

Original fiber (1955) was plastic
organic polymer core rather than glass)

80 μ core of PolyMethylMethylAcrylate (PMMA)

Large Dia \Rightarrow Easy to connectorise, cheap installation

Higher attenuation and Lower bandwidth than
multimode fiber

Can use 570-650 nm (visible light) LEDs and lasers
Laser pointers produce 650 nm)

OK for short distance applications and home use

Cheaper Devices: Plastic amplifiers, Plastic wave
guide grafting routers, plastic lasers

Hard Polymer Clad Silica Fiber

200 micron glass core \Rightarrow Easy to join

Uses same wave length (650nm) as plastic fiber

Lower attenuation and lower dispersion than plastic fiber

55 Mbps ATM PHY spec for plastic and HPCF up to 100m.

Amplifiers

Erbium-Doped Fiber Amplifiers (EDFAs)

Flat response in 1535-1560 nm

Can be expanded to 40 nm width

Dynamic Non-linearity: Response changes if one channel is not used \Rightarrow problem as channels are dropped and added

Causes rapid transient power fluctuations if there are multiple EDFAs in a link

Upcoming Technologies

Simple Optical Networks: Wavelength add-drop, broadcast and select

Wavelength Routed Networks: One wavelength end-to-end

Optically Switched Networks: Wavelength routing with conversion

Optical Time Domain Multiplexing (OTDM): SONET-like synchronous connections

Optical Packet Switching: Need optical logic

Broadcast and Select Networks

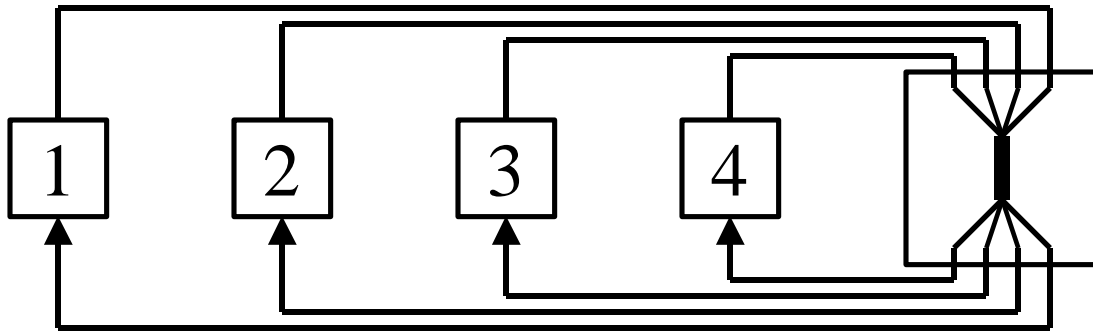

Early 1990 used in LANs, e.g., Rainbow-1

Propagation delays \Rightarrow Limited to LANs

Non-tunable transmitters and receivers

Tunable transmitters \Rightarrow Space division switch

Tunable receivers \Rightarrow Allows multicasts

Both tunable \Rightarrow Allows more nodes than λs

Broadcast \Rightarrow Power wasted

\Rightarrow Amplifiers just before the receiver filter

Centralized WDM Switch

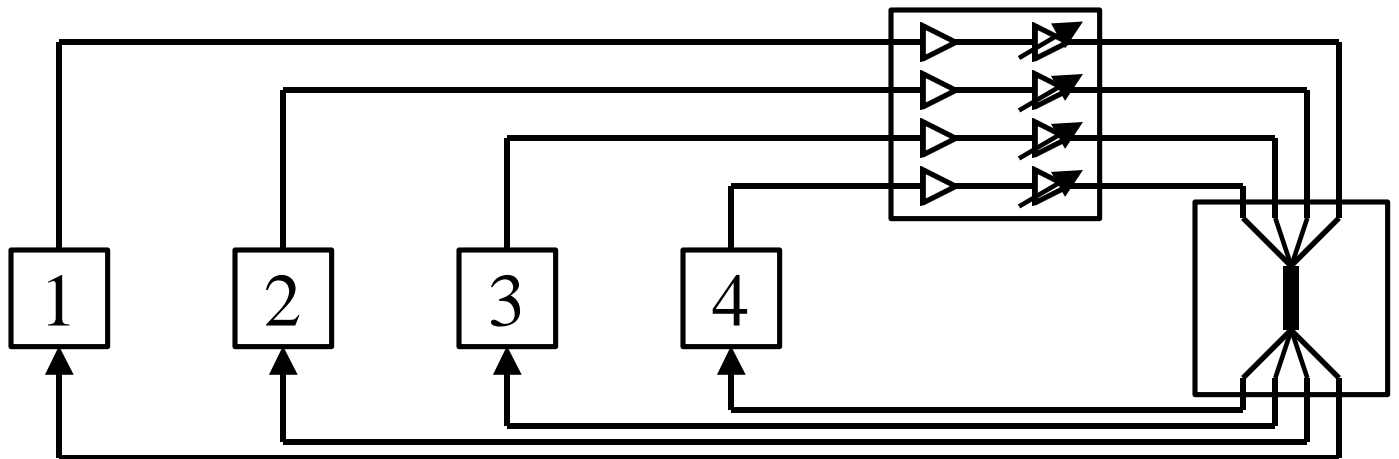

• Tunable components moved to a central switch
• Each station has a preassigned receive wavelength
• Switch converts the signal to receiver wavelength

Wavelength Router

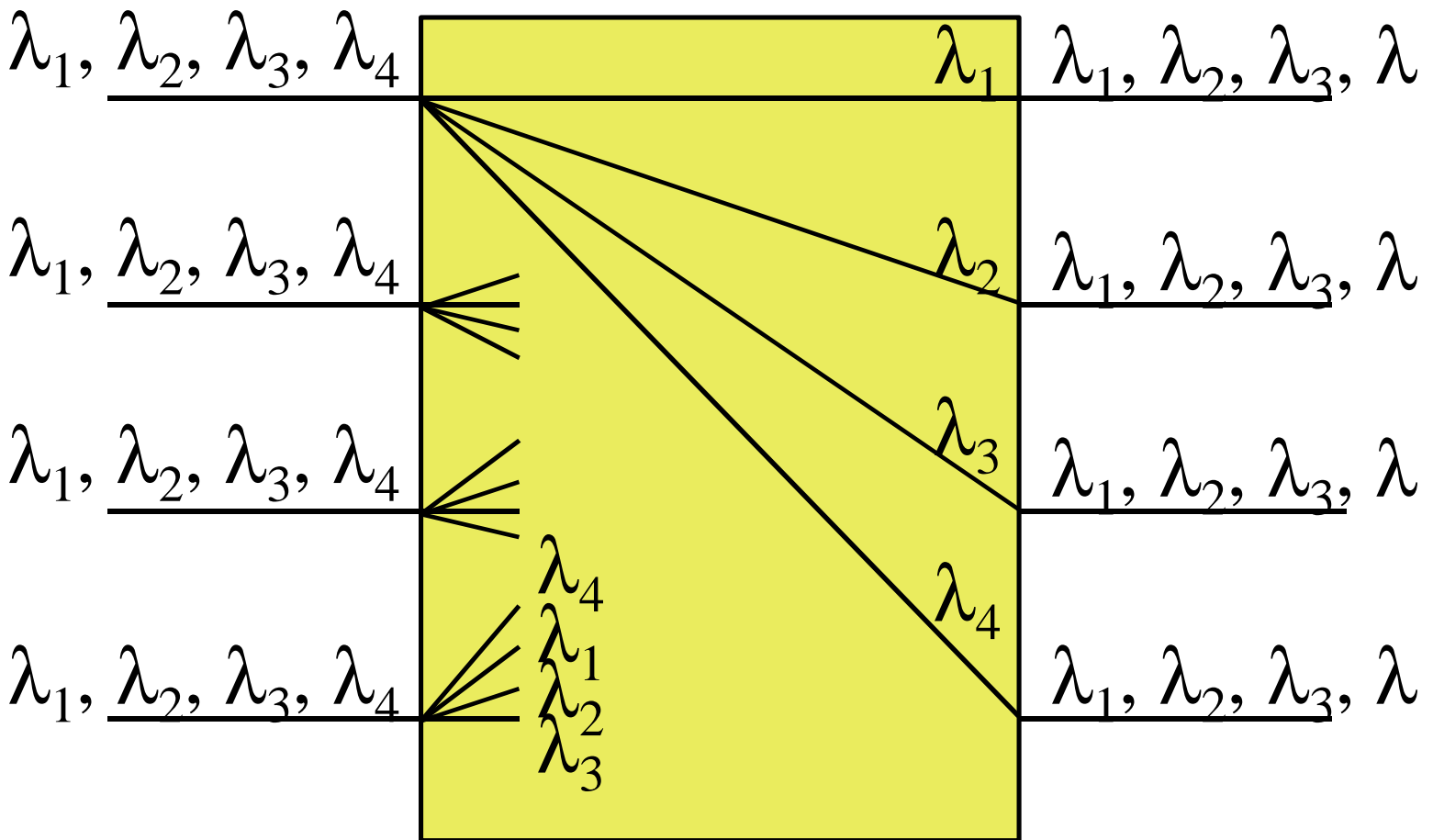

Router = Crossconnect with wavelength conversion

Wavelength Routed Networks

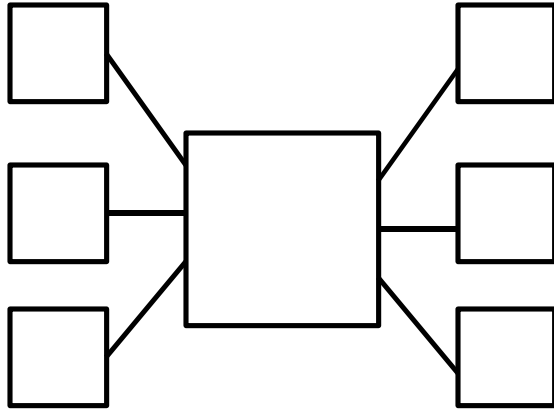

Either transmitters, receivers, or both tunable.

Switches are programmable.

Signaling channel could be electronic or optical

Wavelength collisions \Rightarrow Suitable for medium size networks.

Wavelength converters help avoid wavelength collisions

Optical Time Division Multiplexing (OTDM)

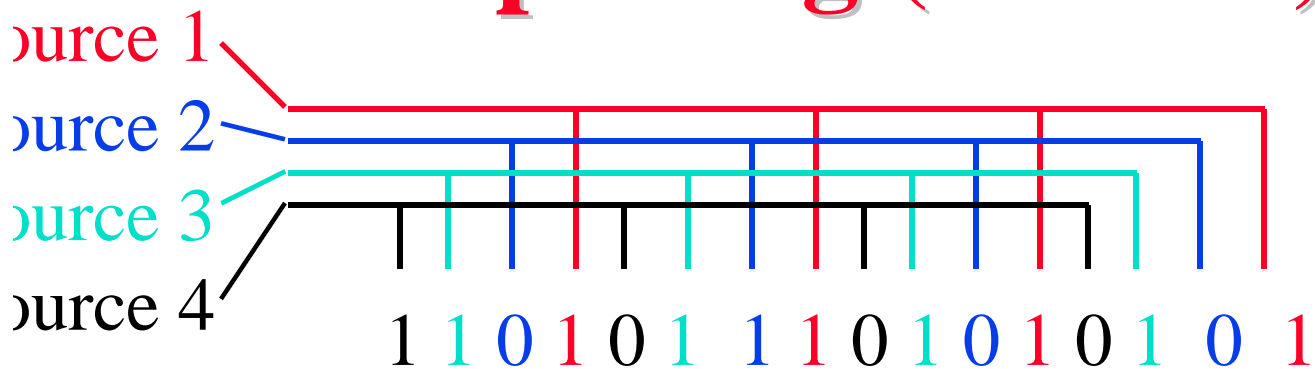

Optics faster than electronics \Rightarrow Bit multiplexing.

OTDM Implementation

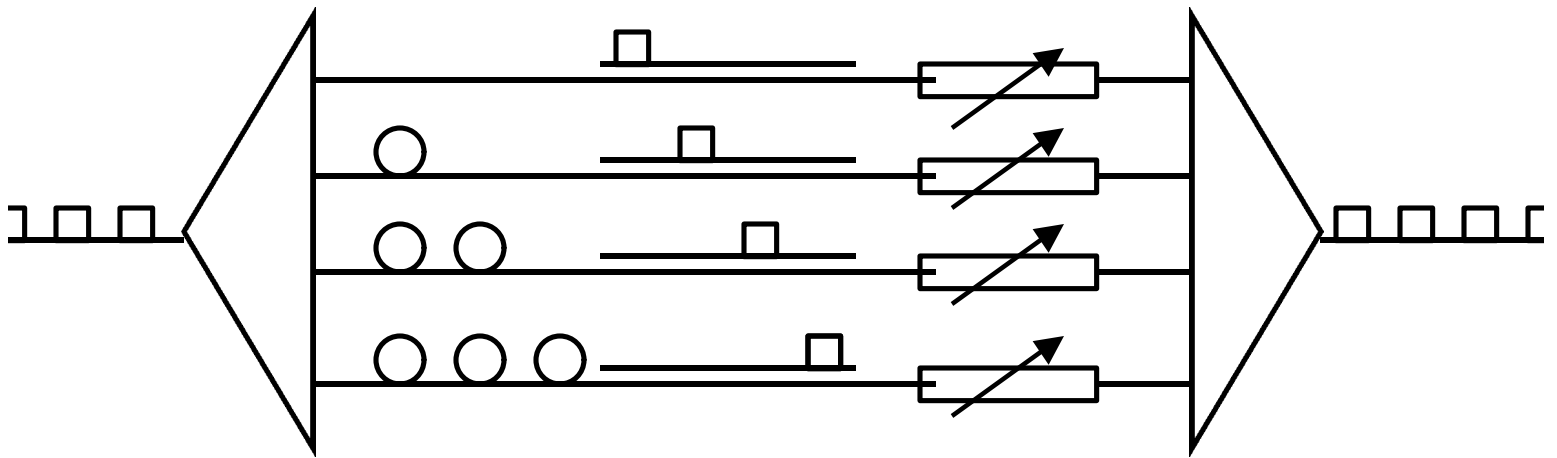

Splitter Delay lines Modulators Combine

A laser produces short pulses.

Pulse stream divided into 4 substreams

Each substream modulated by different source

Substreams combined.

Solitons

Light velocity is a function of amplitude

⇒ Index of dispersion is non-linear:

- $n = n_0 + n_2 E^2$, Where, E = field strength
- No dispersion if the pulse is $\text{sech}(t)$

Need high amplitude pulses (100 mW) and high nonlinearity

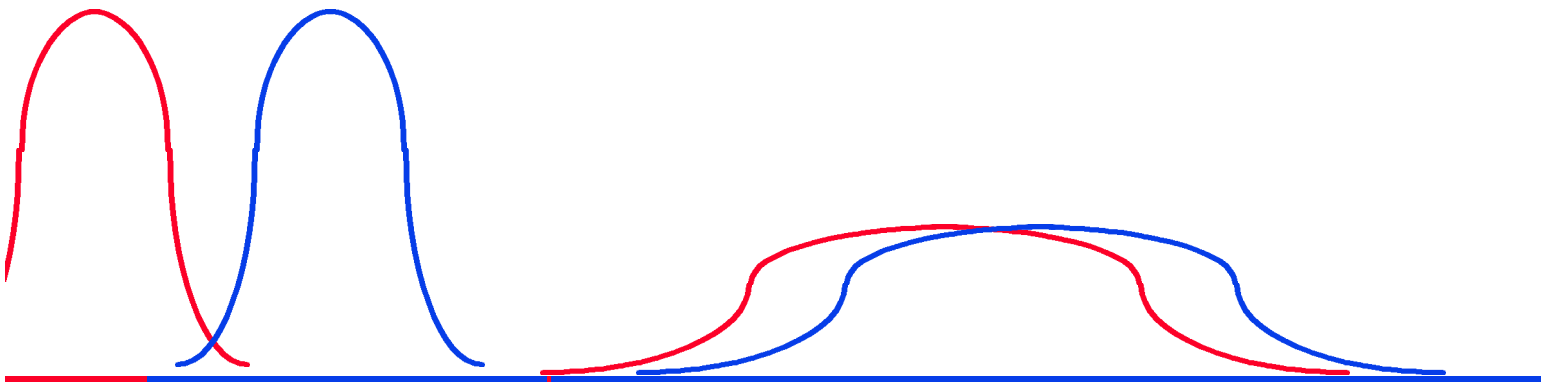

Summary

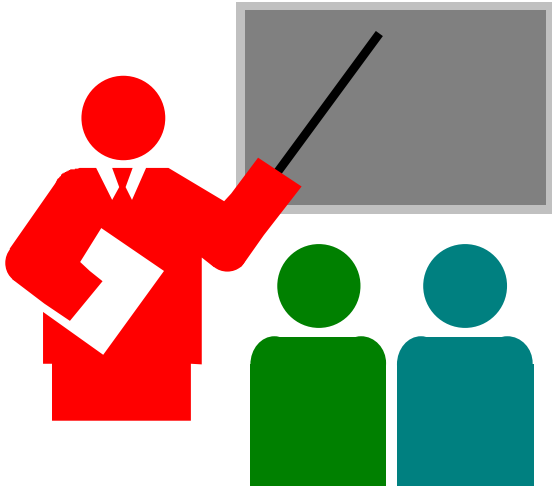

DWDM allows 32- to 64- channels per fiber

Several new types of fibers with different dispersion characteristics

Wavelength routers will allow all-optical networks

References:

See references in http://www.cis.ohio-state.edu/~jain/refs/opt_refs.htm

Recommended books on optical networking,
http://www.cis.ohio-state.edu/~jain/opt_book.htm

Newsgroup: sci.optics.fiber

Organizations

National Transparent Optical Network Consortium (NTONC) connects San Francisco and Los Angeles 10 Gbps. Link is a part of DARPA's SuperNet.

NTONC members include Nortel, GST Telecommunications, Lawrence Livermore National Laboratory, and Sprint

Data Aware Transport Activity (D.A.T.A.) for data over SONET