

Residential Broadband: Technologies for High-Speed Access To Homes

Raj Jain

The Ohio State University

Columbus, OH 43210

Jain@CIS.Ohio-State.Edu

<http://www.cis.ohio-state.edu/~jain/cis788-97/>

Email questions to mbone@netlab.ohio-state.edu



- ❑ 56 kbps Modems, ISDN
- ❑ ADSL, VDSL
- ❑ HFC, FTTC, FTTH
- ❑ Cable Modems
- ❑ IEEE 802.14 standard

Potential Applications

- ❑ Video on demand (VOD)
- ❑ Near video on demand (NVOD)
 - staggered starts
- ❑ Distance learning, Teleconferencing, Home shopping
- ❑ Telecommuting
- ❑ Meter reading
- ❑ Security

Existing cable TV has the media but no switching

Existing phone service has switching but not enough bandwidth

56 kbps Modems

- Past:

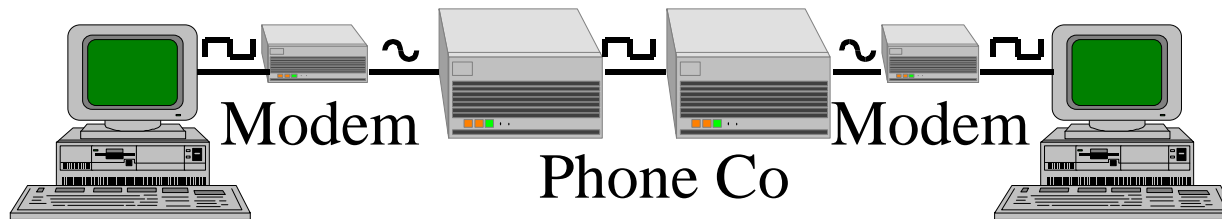

- Current:

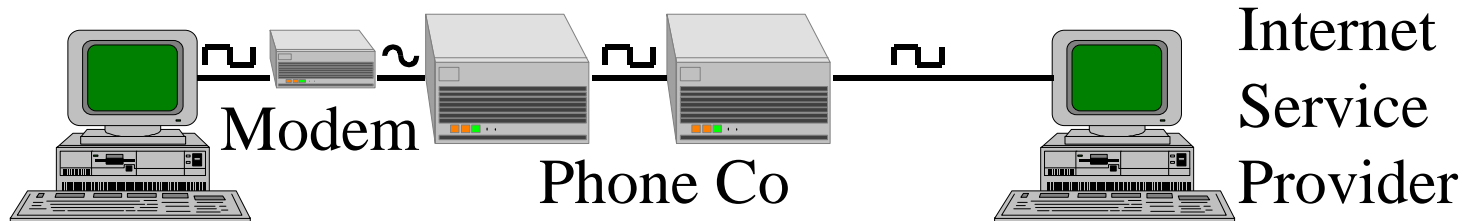

- ISP's have direct digital link (T1 or T3)
- Only one D/A/D conversion \Rightarrow Higher speed possible

Residential Access Networks (RANs)

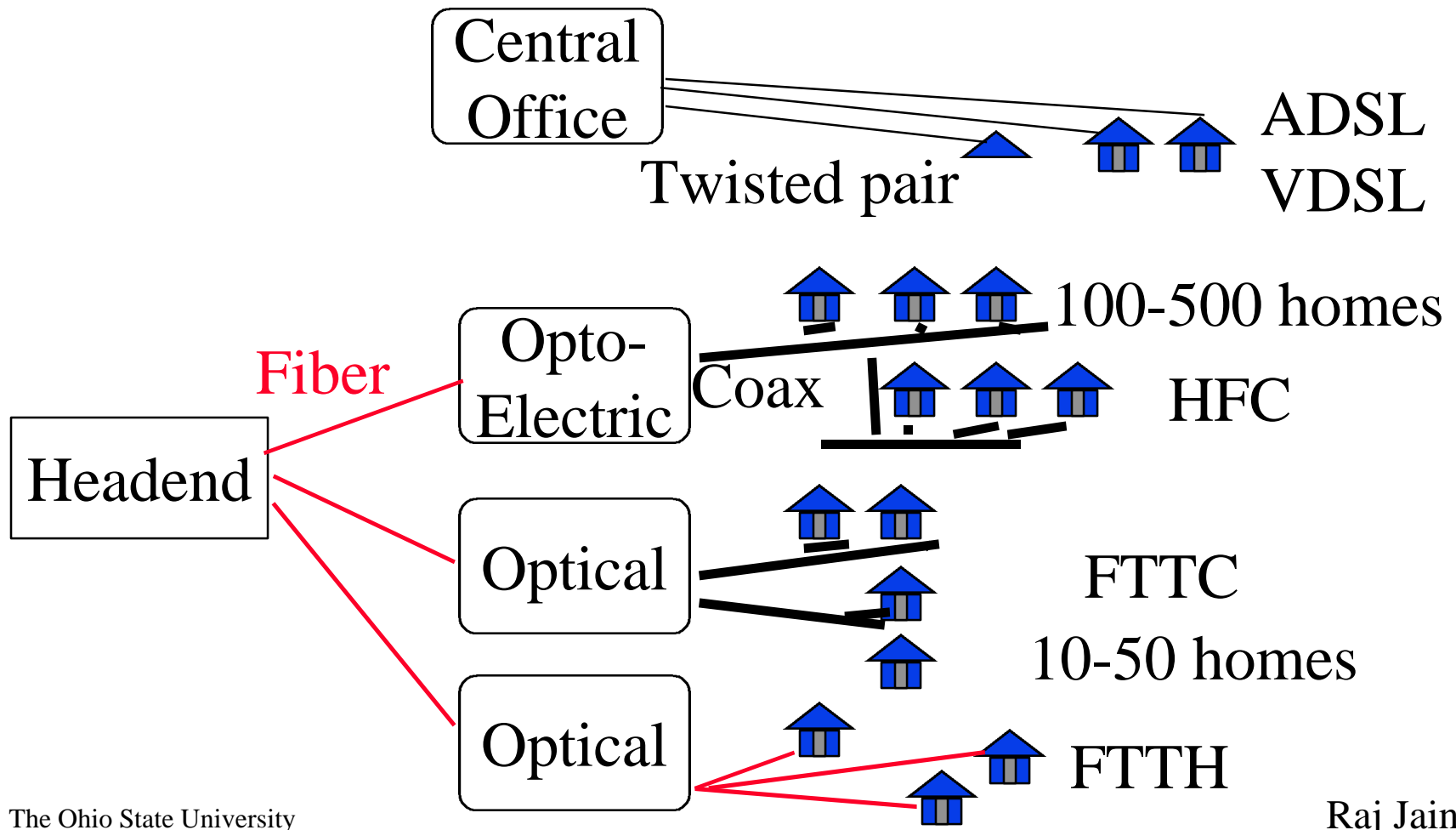

Why Modems are Low Speed?

- ❑ Telephone line bandwidth = 3.3 kHz
- ❑ V.34 Modem = 28.8 kbps \Rightarrow 10 bits/Hz
- ❑ Better coding techniques. DSP techniques.
- ❑ Cat 3 UTP can carry higher bandwidth
- ❑ Phone companies put 3.3 kHz filters at central office \Rightarrow Allows FDM

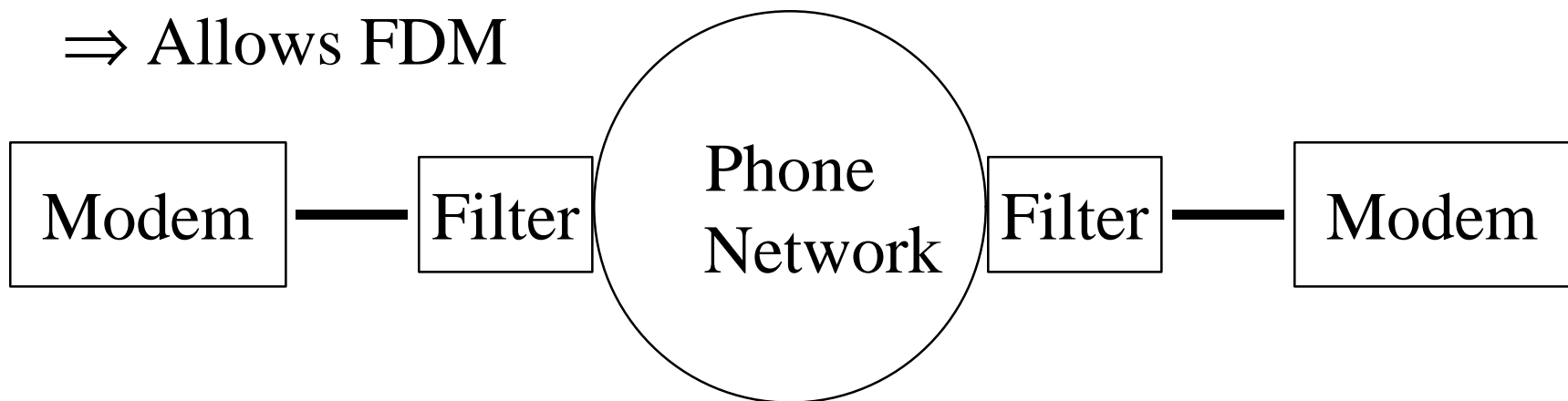

DSL

- ❑ Digital Subscriber Line = ISDN
- ❑ $64 \times 2 + 16 + \text{overhead}$
= 160 kbps up to 18,000 ft
- ❑ DSL requires two modems (both ends of line)
- ❑ Symmetric rates \Rightarrow transmission and reception on same wire \Rightarrow Echo cancellation
- ❑ Use 0 to 80 kHz \Rightarrow Can't use POTS simultaneously

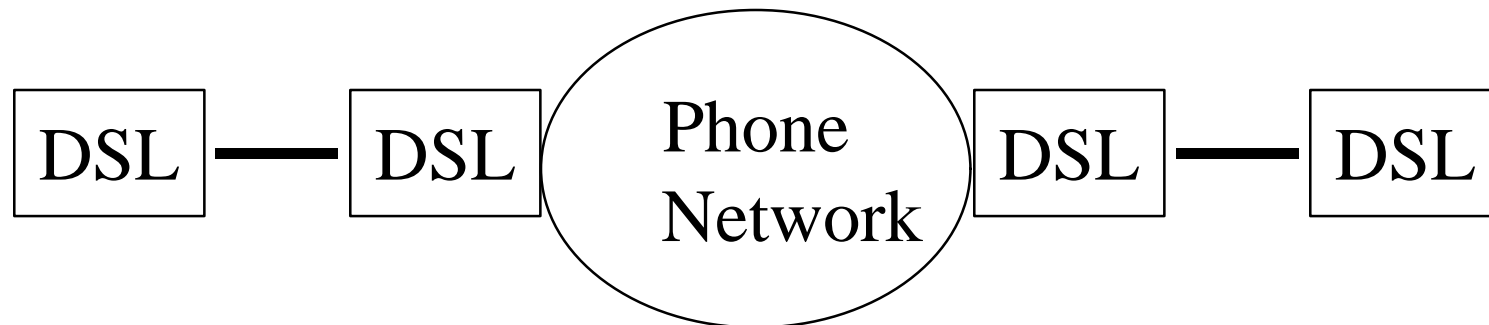

DSL Technologies

- ❑ DSL: Digital Subscriber Line (ISDN)
- ❑ HDSL: High data rate DSL (T1/E1 on 2 pairs)
- ❑ SDSL: Single line DSL (T1/E1+POTS on 1 pair)
- ❑ ADSL: Asymmetric DSL
- ❑ RADSL: Rate-adaptive ADSL
- ❑ VDSL: Very high data rate DSL
- ❑ VADSL: Very high data rate Asymmetric DSL
= VDSL
- ❑ BDSL: Another name for VDSL
- ❑ VDSL_e: European version of VDSL

HDSL

- ❑ Initially T1/E1 over copper used AMI coding \Rightarrow Repeaters every 3000 - 6000 ft
- ❑ Uses 1.5 MHz for 1.5 Mbps \Rightarrow Wasteful of bandwidth \Rightarrow Interference \Rightarrow Can't put more than 1 circuit in a 50 pair cable
- ❑ HDSL transmits T1/E1 over two pairs using 80 to 240 kHz \Rightarrow repeaters at 12,000 ft
- ❑ Used in PBX interconnection, cellular antenna stations, interexchange POPs
- ❑ SDSL = Single pair version of HDSL. Allows POTS and T1/E1 simultaneously. Up to 10000 ft.

ADSL

- ❑ Asymmetric Digital Subscriber Line
- ❑ Asymmetric \Rightarrow upstream \ll Downstream
- ❑ Symmetric \Rightarrow Significant decrease in rate
- ❑ 6 Mbps downstream, 640 kbps upstream
- ❑ Using existing twisted pair lines
- ❑ No interference with phone service (0-3 kHz)
 \Rightarrow Your phone isn't busy while netsurfing
- ❑ Up to 7500 m
- ❑ ANSI T1.413 Standard
- ❑ Quickest alternative for Telcos

Why Asymmetric?

- ❑ Unshielded twisted pair \Rightarrow Crosstalk
- ❑ Downstream signals are all same amplitude \Rightarrow Not affected
- ❑ Upstream signals start at different distances \Rightarrow Different amplitudes \Rightarrow Weak signals are highly affected
- ❑ Solutions:
 1. Use asymmetric rates
 2. Use lower frequencies for upstream
(Cross talk increases with frequencies)

ADSL Status

- ❑ ADSL modems have been tested successfully by over 30 phone companies
- ❑ InterAccess Inc (Internet service provider) offers 1.5 Mbps/64 kbps ADSL in downtown Chicago. \$200 per PC or \$1000 per LAN.
- ❑ Microsoft + Westell to support ADSL in Windows NT server \Rightarrow MS Public Network Platform
- ❑ Microsoft + General Instrument, Zenith, and Motorola to support cable modems

VDSL

- ❑ Very High-Speed Digital Subscriber Lines
- ❑ Also called VADSL, BDSL, VHDSL
- ❑ ANSI T1E1.4 standardized the name VDSL and ETSI also adopted it
- ❑ VDSL_e to denote European version
- ❑ For use in FTTC systems
- ❑ Downstream Rates: 51.84 -55.2 Mbps (300 m), 25.92-27.6 Mbps (1000 m), 12.96 - 13.8 Mbps (1500 m)

VDSL (Cont)

- ❑ Upstream Rates: 1.6-2.3 Mbps, 19.2 Mbps, Same as downstream
- ❑ Admits passive network termination
⇒ Can connect multiple VDSL modems like extension phones
(ADSL requires active termination)
- ❑ Unlike ADSL, VDSL uses ATM to avoid packet handling and channelization
- ❑ Orkit Communications (Israel) demoed VDSL modems at Supercomm'96

Hybrid Fiber Coax (HFC)

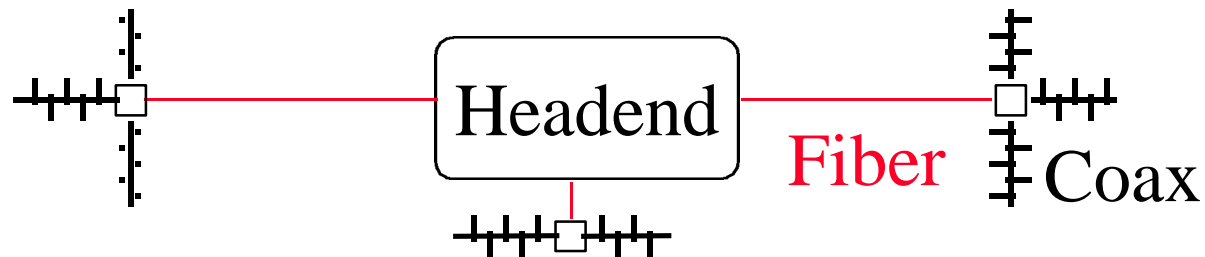

- ❑ Reuse existing cable TV coax
- ❑ Replace trunks to neighborhoods by fibers
- ❑ 45 Mbps downstream, 1.5 Mbps upstream
- ❑ MAC protocol required to share upstream bandwidth
- ❑ 500 to 1200 homes per HFC link
- ❑ Sharing \Rightarrow Security issues
- ❑ IEEE 802.14 is standardizing MAC and PHY

Cable Modems

- ❑ Modulate RF frequencies into cable.
Signal received at the headend and converted to optical
- ❑ Cost \$395 to \$995
- ❑ If cable is still one-way, upstream path through POTS
- ❑ \$30 to \$40 per month flat service charge
- ❑ Successful trials in Canada using 500 kbps modems
- ❑ After the trial 75% users kept the service and paid
- ❑ TCI formed @Home <http://www.home.net>
- ❑ Servers at headend to avoid Internet bottleneck
- ❑ Plans to create high-speed cable backbone across US

Fiber to the Curb (FTTC)

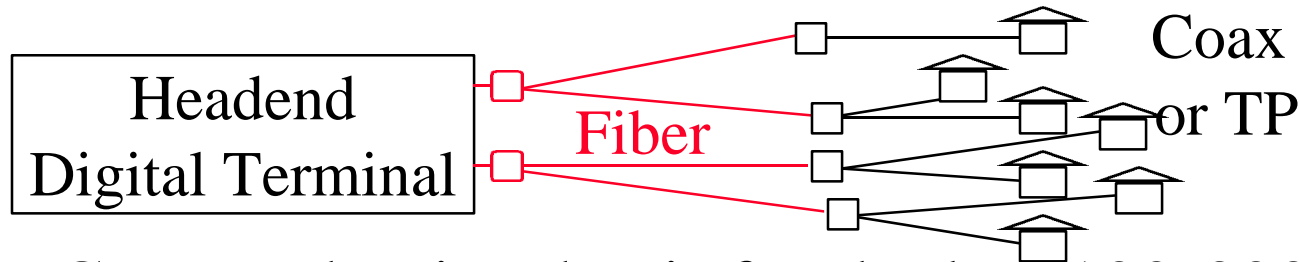

- ❑ Coax and twisted pair for the last 100-300 m
- ❑ Coax is used for analog video, TP is used for POTS
- ❑ Baseband \Rightarrow No frequency multiplexing
- ❑ Passive optical network \Rightarrow signal is optically broadcast to several curbs \Rightarrow Time division multiplexing
- ❑ Up to 50 Mbps downstream, Up to 20 Mbps upstream
- ❑ Co-exist with POTS or ISDN on the same cable pair
- ❑ Twisted pair \Rightarrow EMI \Rightarrow withstand legal 400W radio transmissions at 10 m

Fiber to the Home (FTTH)

- ❑ Fully optical \Rightarrow No EMI
- ❑ Initially passive optical network
 \Rightarrow Time division multiplexing
- ❑ Upstream shared using a MAC
- ❑ 155 Mbps bi-directional
- ❑ Need new fiber installation

Comparison of RANs

Tech-nology	Typical Downstream Rate	Typical Upstream Rate	Max Distance	Homes Per Opt. Unit
HFC	45 Mbps Shared	1.5 Mbps Shared	N/A	500
FTTC	25-50 Mbps	25-50 Mbps	100 m	10-50
FTTH	155 Mbps	155 Mbps	N/A	10-200
ADSL	6 Mbps	640 kbps	4,000 m	1,000
VDSL	13-50 Mbps	1.6-5 Mbps	2,000 m	100

ADSL Vs Cable Modems

ADSL	Cable Modems
Phone company	Cable company
Switching experience but low bandwidth ckts	No switching but high bandwidth infrastructure
Point-to-point \Rightarrow Data privacy	Broadcast. Sharing \Rightarrow More cost effective
Currently 1.5 to 8 Mbps	10 to 30 Mbps
Perf = fn(location)	Independent of location
Phone everywhere	Cable only in suburbs (not in office parks)
Existing customers \Rightarrow ISDN and T1 obsolete	New Revenue

IEEE 802.14

- ❑ CATV Protocol working group
- ❑ Started November 1994
- ❑ Defining PHY and MAC for 2-way HFC
- ❑ Downstream PHY: 1-to-n broadcast
- ❑ Upstream PHY: n-to-1
- ❑ Up to 200 microsecond one-way

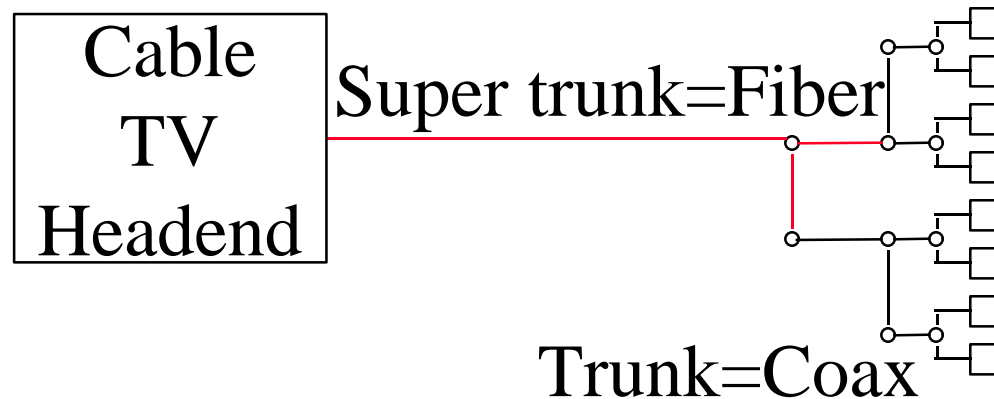

IEEE 802.14 Protocol Stack

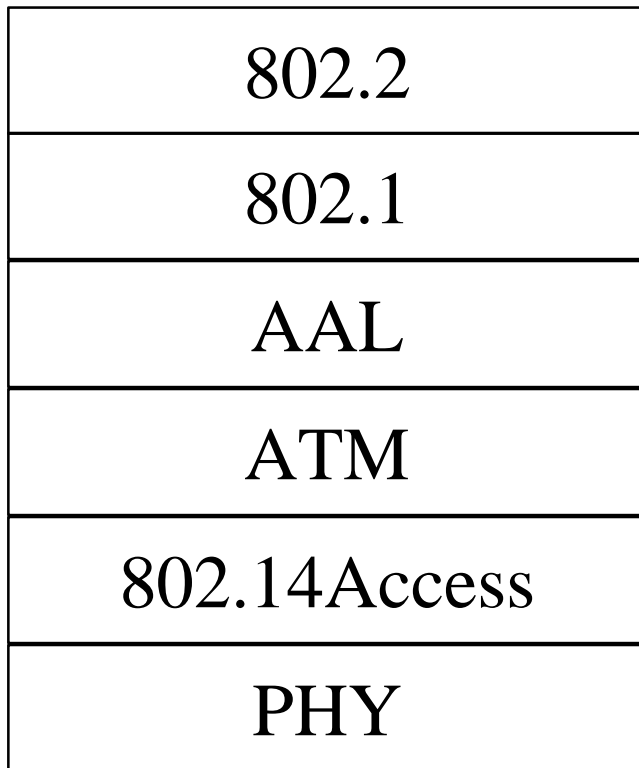

All ATM

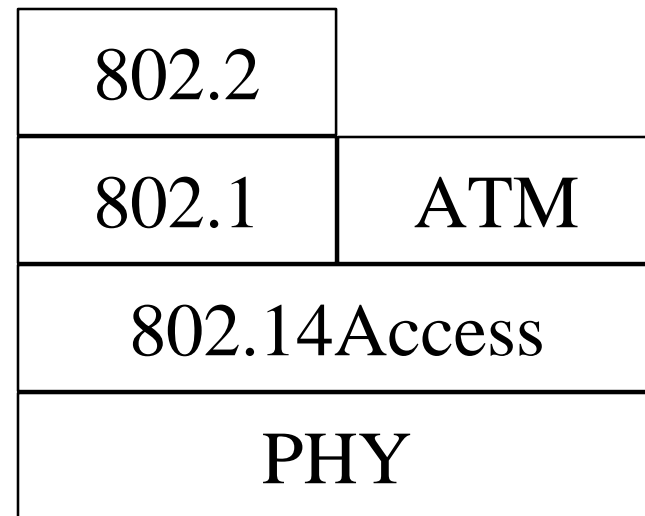

√ATM Friendly

802.14 MAC Issues

- ❑ ATM-based mandatory
- ❑ Addresses: Permanent (48-bit) and 14-bit local id
- ❑ Slot allocation granularity: 6 bytes downstream, Upstream: Minislot = 8 bytes data + Phy + Guard
- ❑ Contention method: Ternary tree

IEEE 802.14 PHY

- ❑ 500 homes as a reference design point
- ❑ Support sub-split (5-65 MHz upstream), mid-split (5-108 MHz upstream), and high-split (5-174 MHz upstream)
- ❑ Quadrature Amplitude Modulation (QAM) 64 and 256 for downstream.
⇒ 6 bits/Hz ⇒ 30 Mbps on 6 MHz ⇒ 27 Mbps w FEC
- ❑ Quadrature Phase Shift Keying (QPSK) and 16-QAM for upstream to sustain high noise
⇒ 1.5 to 3 Mbps on 2 MHz
- ❑ Several upstream channels per downstream channel

QAM

- ❑ Quadrature Amplitude Modulation, 16-QAM, 64-QAM
- ❑ Two waves 90° apart are amplitude modulated using $n/2$ bits each to produce 2^n -QAM
- ❑ Used in V.34 modems.

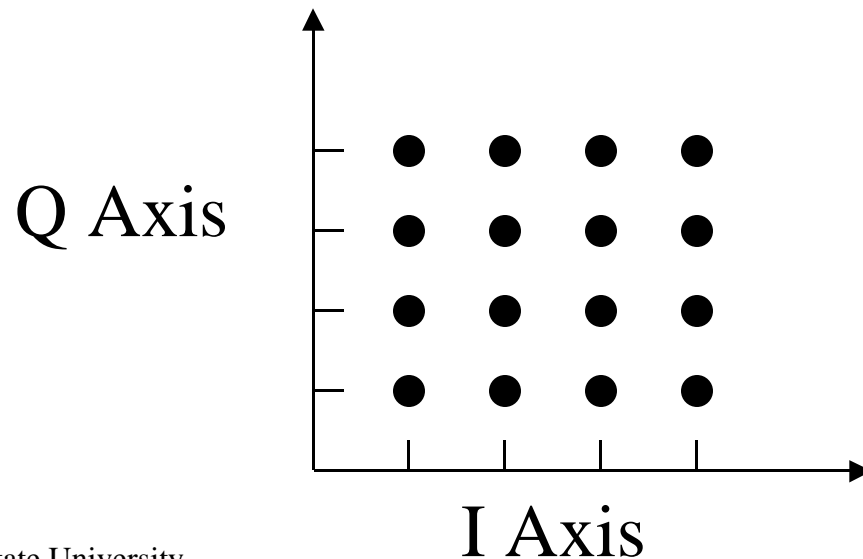

Satellites for Data

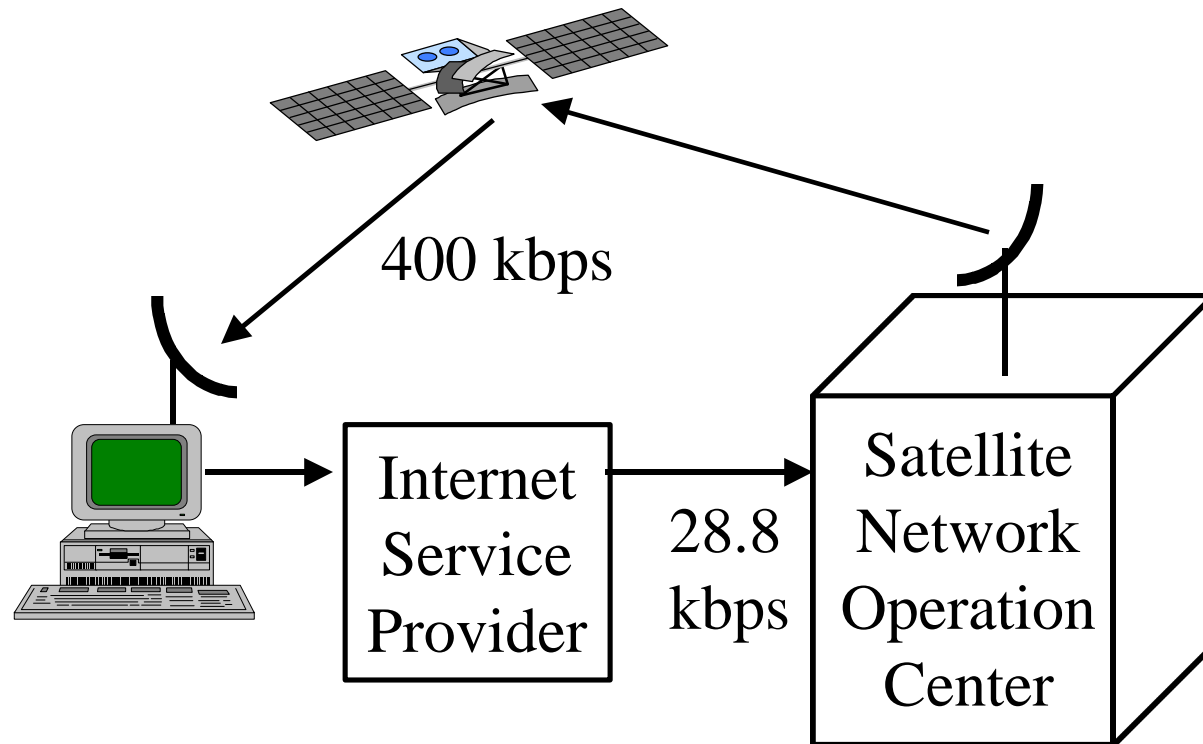

- ❑ DirecPC from Hughes
- ❑ One-way high-speed connection

Wireless Local Loop

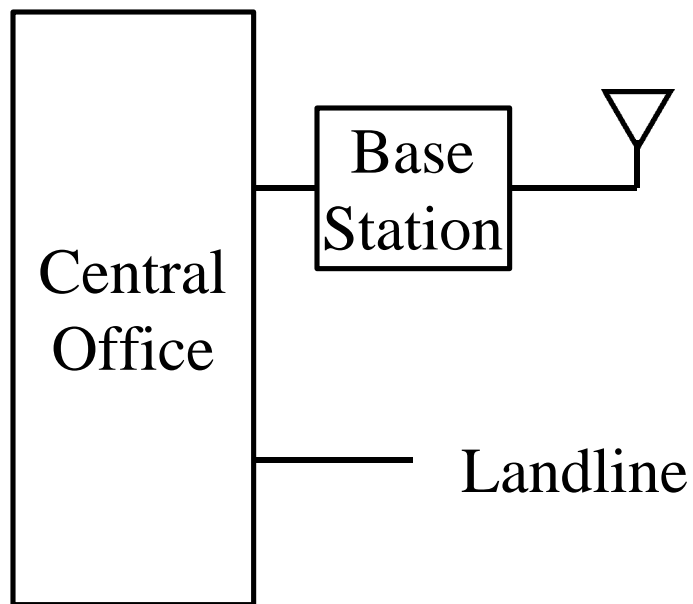

- ❑ Fixed, high, directional antennas \Rightarrow Lower loss, no handoff

Summary

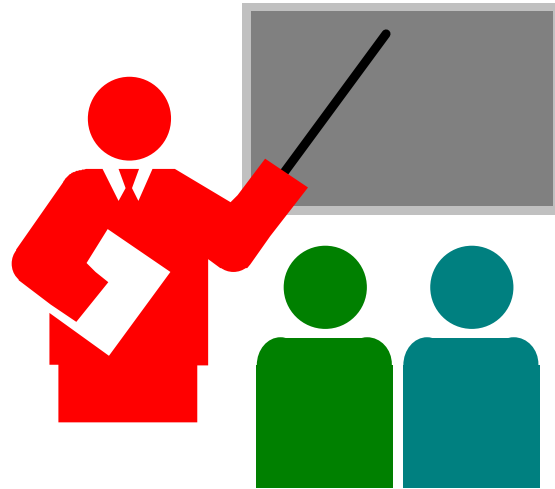

- ❑ High Speed Access to Home:
ADSL, VDSL, HFC, FTTC, FTTH
- ❑ 6 to 155 Mbps downstream, 1.5 Mbps upstream
- ❑ Both cable and telecommunication companies are trying to get there with minimal modification to their infrastructure

RBB: Key References

- ❑ For a detailed list of references, see http://www.cis.ohio-state.edu/~jain/refs/rbb_refs.htm
- ❑ IEEE 802.14 Media Access Control, Draft 2 R1, June 20, 1997
- ❑ IEEE 802.14 Physical Layer Specification for HFC networks, Draft, May 16, 1997.
- ❑ ANSI T1.413, ADSL Metallic Interface

References (Cont)

- ❑ IEEE 802.14 Working group,
<http://www.walkingdog.com>
- ❑ The ADSL Forum,
<http://www.sbexpos.com/sbexpos/associations/adsl/home.html>
- ❑ Cable Labs, <http://www.cablemodem.com>
- ❑ IETF IP over Cable Data Network working group,
<http://www.ietf.org/html.charters/ipcdn-charter.html>
- ❑ Cable Modem FAQ,
<http://www.cox.com/modemfaq.html>

Current Schedule

7/17/97 Priority and Multicasting on LANs

7/22/97 **No Class**

7/24/97 Virtual LANs

7/29/97 Gigabit Ethernet

7/31/97 Quiz 2 (No MBone transmission)

8/5/97 Residential broadband: Cable Modems, xDSL

8/7/97 **Multicasting over IP and ATM**

8/12/97 Multimedia over IP: RSVP, RTP

8/14/97 Wireless LANs and WANs

8/19/97 Quiz 3 (No MBone transmission)