

97-0425

**Performance of Bursty
World Wide Web (WWW)
Sources over ABR**

Bobby Vandalore, Shiv Kalyanaraman, Raj Jain,
Rohit Goyal, Sonia Fahmy, and Xiangrong Cai
The Ohio State University

Seong-Cheol Kim, Samsung Electronics Co.

<http://www.cis.ohio-state.edu/~jain/>



- ❑ Goal: Bursty TCP Performance over ABR
- ❑ Concern: ABR, UILI, Slow start policies may adversely affect bursty traffic
- ❑ Workload: SpecWeb'96 traffic (Modified)

SPECWeb96

- ❑ Majority of traffic on the Internet is WWW
- ❑ Developed by Standard Performance Evaluation Corporation (SPEC)
- ❑ A consortium similar to ATM Forum for performance benchmarking
- ❑ SPECMark, SPEC CPU95, SPECInt95, SPEC SFS
- ❑ SPECWeb96 is for benchmarking WWW servers
- ❑ Ref: <http://www.specbench.org/ost/web96/webpaper.html>

SPECWeb96

Class 0	Class 1	Class 2	Class 3
$p = 0.35$	$p = 0.5$	$p = 0.14$	$p = 0.01$
0.1 kB	1 kB	10 kB	100 kb
0.2 kB	2 kB	20 kB	200 kB
...
0.9 kB	9 kB	90 kB	900 kB

- Each column has a given probability of access.
- Each row of the column then has a given probability of access (Poisson distribution centered around the midpoint of the class).

Problem with SPECWeb96

- ❑ Average File Size = 120.2 kB
- ❑ 10-sec think time
⇒ Average load = 60 kbps per user
- ❑ Low bandwidth per user
⇒ Need a very large number of users to fill 155 Mbps
- ❑ Solution: Use 150 or so users on 45 Mbps link.
- ❑ Also modified the workload to make 10 times more demand per user.

Modified SPECWeb96

Class 0	Class 1	Class 2	Class 3	Class 4
$p = 0.2$	$p = 0.28$	$p = 0.40$	$p = 0.112$	$p = 0.008$
0.1 kB	1 kB	10 kB	100 kb	1 MB
0.2 kB	2 kB	20 kB	200 kB	2 MB
...
0.9 kB	9 kB	90 kB	900 kB	9 MB

- ❑ Each Web page consists of one index page and 4 images.
- ❑ First Column: Index page ($p = 1/5$)
- ❑ Other Columns: $p = 0.8$ Probability of class $n-1$ in the original SPECweb96

Modified SPECWeb96 (Cont)

- ❑ Average File size = 120.3 kB
- ❑ Bandwidth per user = 0.48 Mbps
- ❑ HTTP 1.1 \Rightarrow All components of a web page are fetched in one TCP connection.

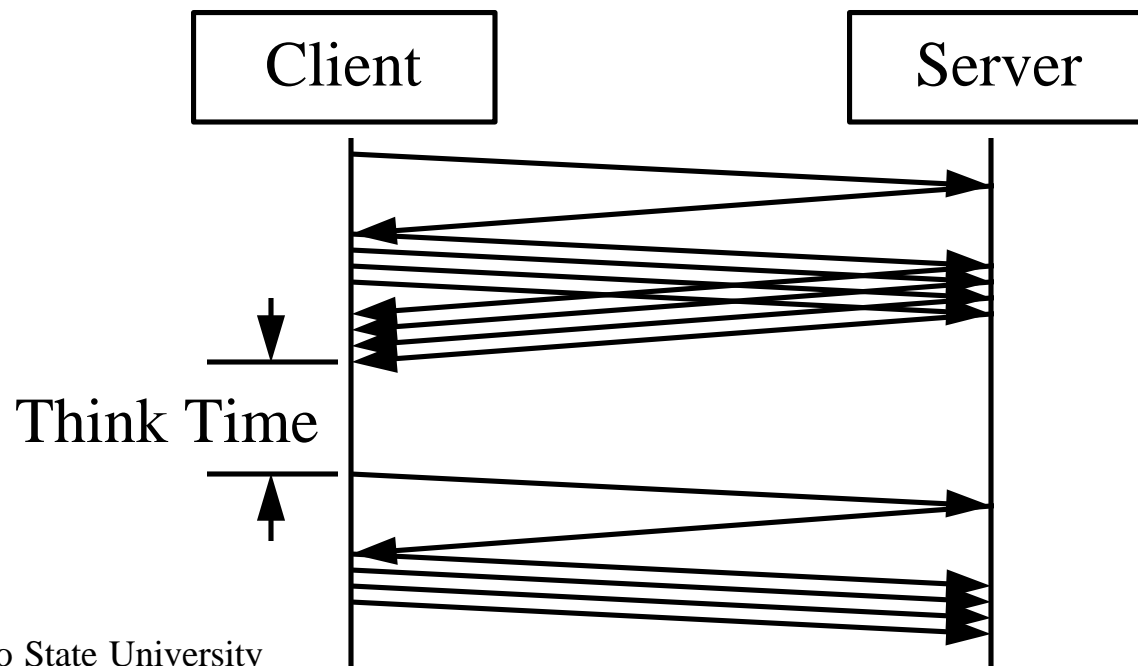

K-N Client-Server Configuration

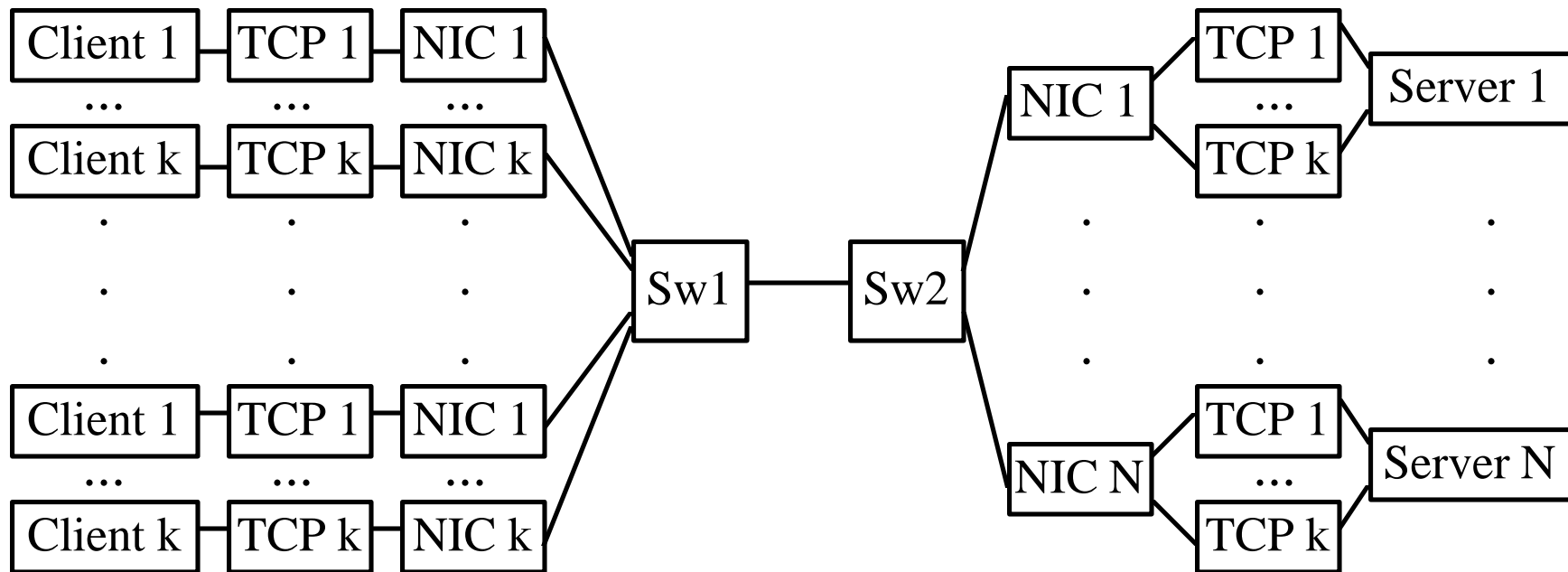

- ❑ K clients per server, $K=15$
- ❑ N servers, $N=1, 2, 5, 10$
- ❑ Total $K*N$ VCs
- ❑ Note: Typo in contribution $10 \text{ ms} = 3667 \text{ cells}$ (not 3680)

Parameters

- ❑ TCP Parameters:
 - ❑ Window = 16×64 kB (on WANs with 30 ms RTT)
 - ❑ MSS = 512 Bytes \Rightarrow 12 cells per segment
 \Rightarrow Maximum TCP payload = 78% of link rate
= 35.1 Mbps on T3
- ❑ ERICA Parameters:
 - ❑ Averaging interval = $\text{Min}\{500 \text{ cells}, 5 \text{ ms}\}$
 - ❑ Queue thresholds:
 $T_0 = 500 \mu\text{s}$, $a=1.15$, $b=1.05$, $\text{QDLF} = 0.5$
- ❑ Workload Parameters:
 - ❑ Inter-batch time = 10 seconds
 \Rightarrow 72 Mbps on the T3 link with 150 clients

Simulation Results

# of Servers	Max Switch Q (Cells)	TCP Throughput	Efficiency
1	3677 = 1.0 F	6.1 Mbps	17.4%
2	6154 = 1.7 F	14.2 Mbps	40.3%
5	14057 = 3.8 F	34.1 Mbps	97.1%
10	17269 = 4.7 F	32.7 Mbps	93/2%

F = Feedback delay

- ❑ Queues increase linearly first, then stabilize
- ❑ Queue lengths are a small multiple of the feedback delay.
- ❑ Efficiency increases linearly first, then stabilizes
- ❑ Efficiency is high.
- ❑ ABR is stable even under bursty TCP traffic.