

# **97-0614: Modifications to the Throughput Section of Performance Testing Baseline Text**

Gojko Babic, Arjan Duresi, Raj Jain, Justin Dolske  
The Ohio State University

Contact: Jain@cis.ohio-state.edu

<http://www.cis.ohio-state.edu/~jain/>



- ❑ Description of foreground traffic characteristics

# Throughput

- ❑ More precise measurement procedure
- ❑ No variation  $\Rightarrow$  No repetitions  
 $\Rightarrow$  Removed standard deviation and mean

# Connection Configurations for Foreground Traffic

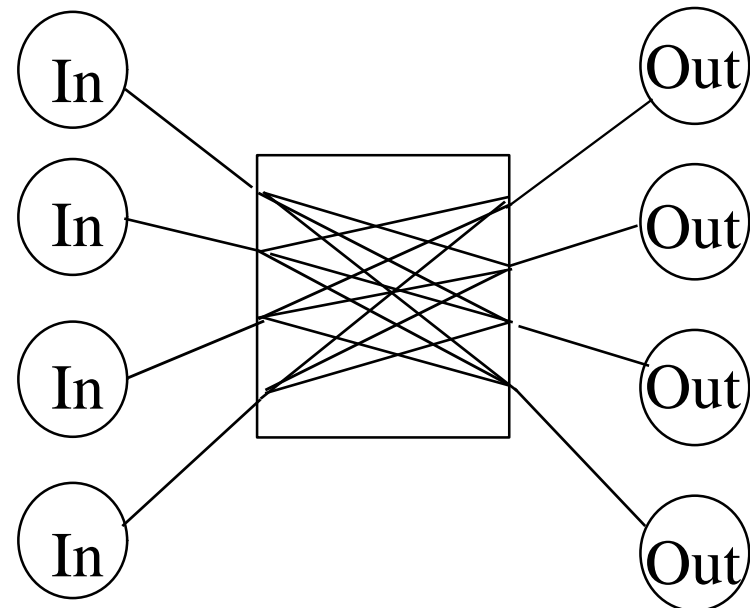
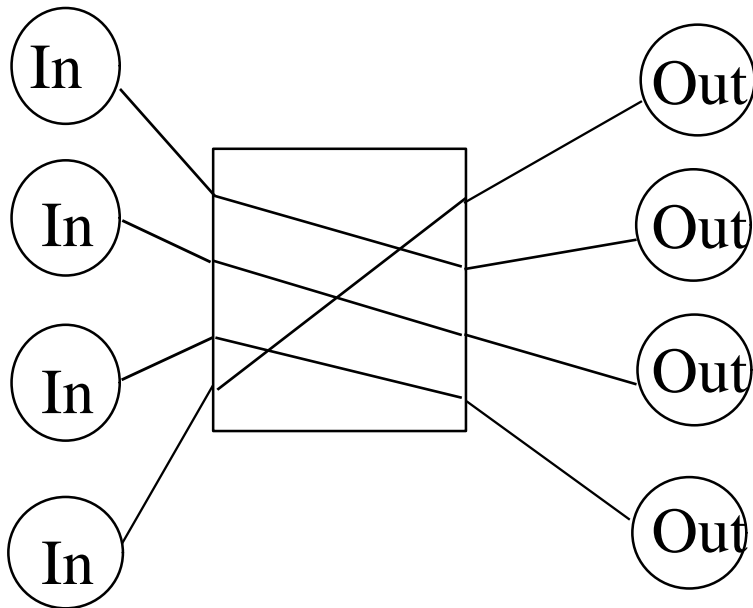

- a.**  $n$ -to- $n$  straight:  $n$  VCCs;  $n=4$       **b.**  $n$ -to- $(n-1)$  full cross:  $n \times (n-1)$  VCCs;  $n=4$

Note: Inputs are shown on the left. Outputs on the right.

# Configurations (Cont)

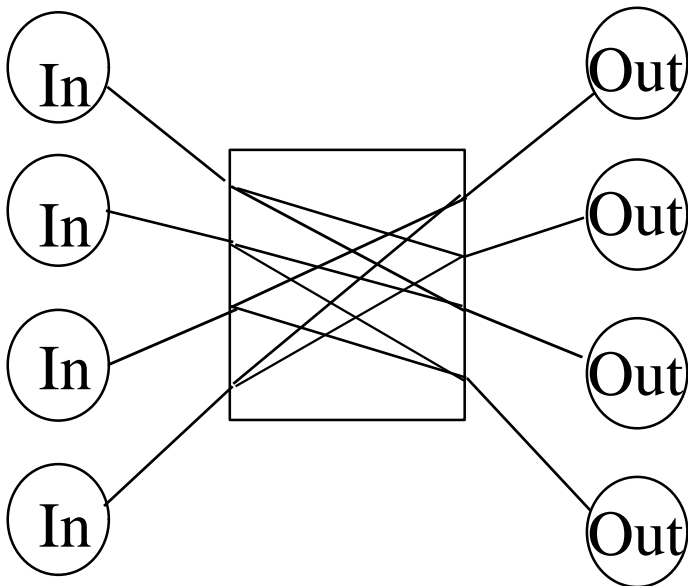

c. n-to-m partial cross:  $n \times m$  VCCs;  
 $n=4$ ,  $m=2$

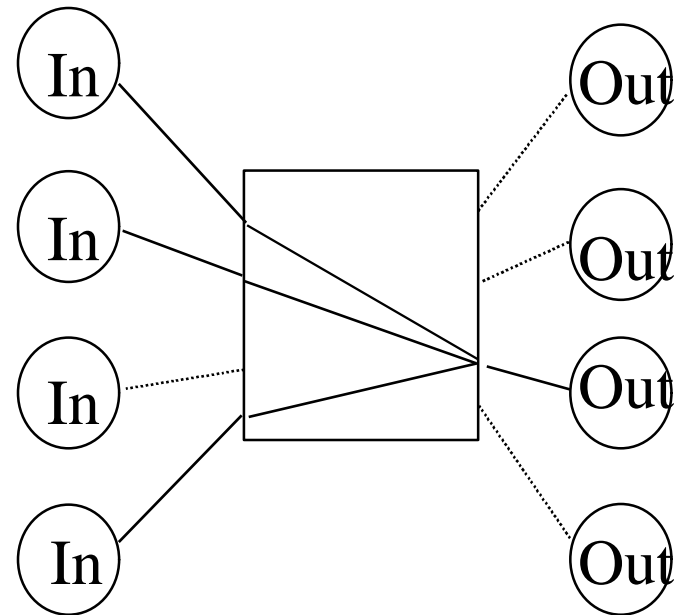

d. k-to-1:  $k$  VCCs;  $k=3$

□ Note: Inputs are shown on the left. Outputs on the right.

# Configurations (Cont)

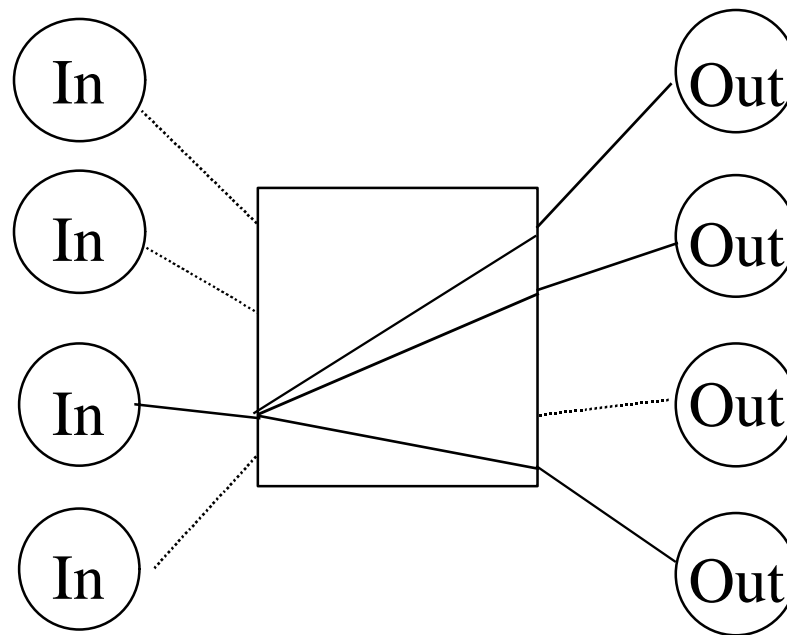

e. 1-to-(n-1): one (multicast) VCC

□ Note: Inputs are shown on the left. Outputs on the right.

# Configurations (Cont)

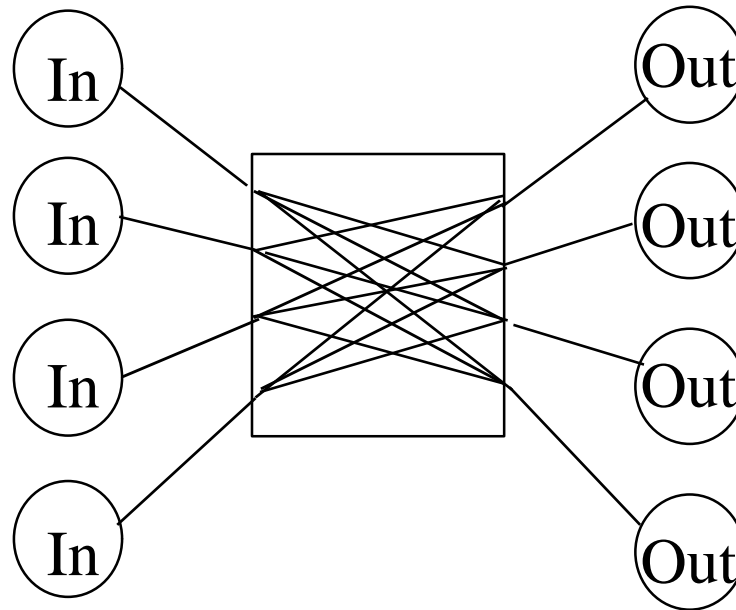

f.  $n$ -to- $(n-1)$  multicast:  $n$  (multicast) VCCs;  $n=4$

□ Note: Inputs are shown on the left. Outputs on the right.

# Service Classes, Arrival Patterns and Frame Lengths

**1. UBR service class:** Equally spaced frames of fixed length. Each frame includes number of back-to-back cells (AAL payload size: 64 B, 1518 B, 9188 B, 64 kB).

*Under study: Variable length frames and other arrival patterns .*

**2. ABR and VBR service classes:** under study.

# Scaleable Test Configurations

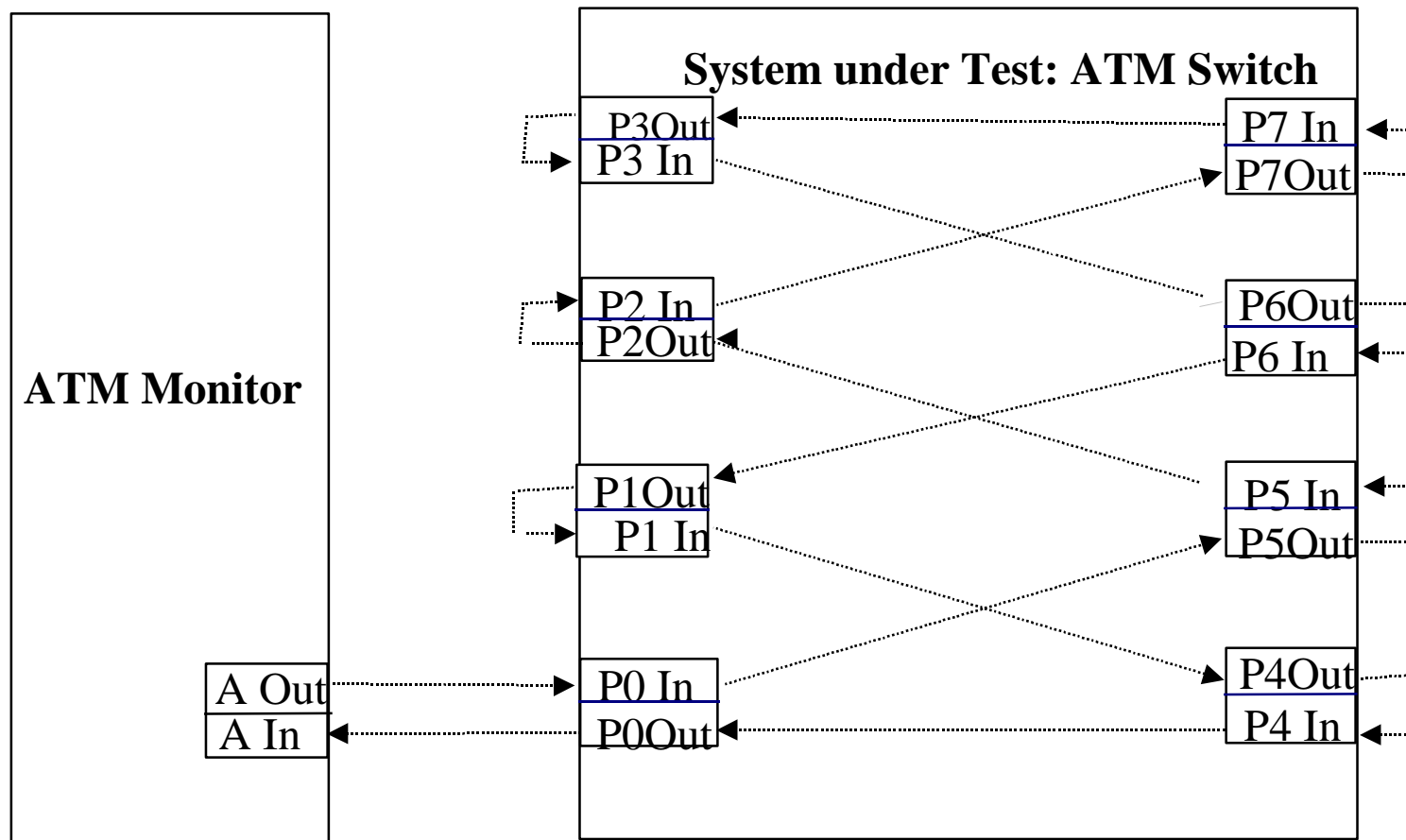

n-to-n Straight

# Scaleable Test Configurations II

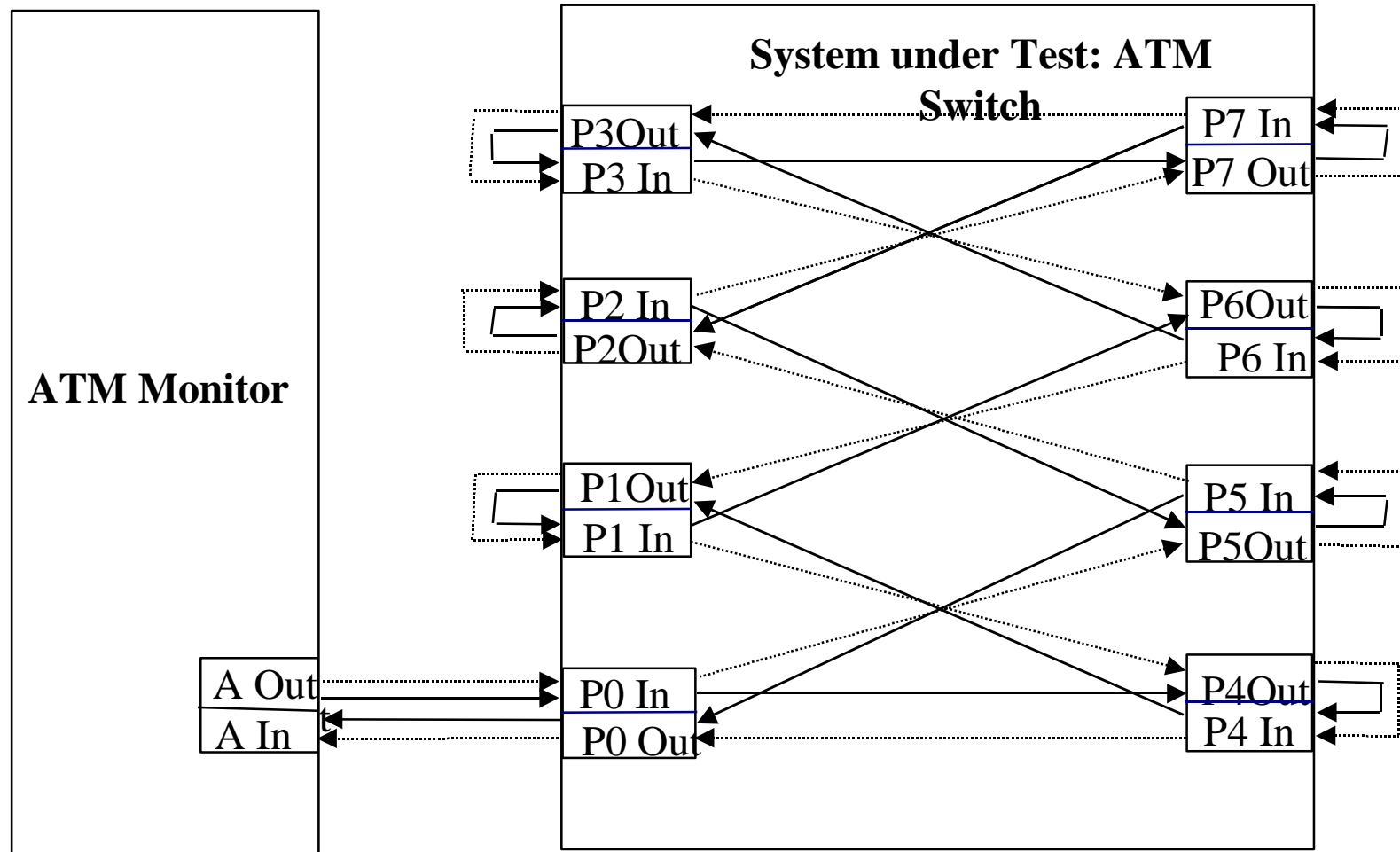

8-to-2 partial cross

# Guidelines for Scalable Test Configurations

- ❑ Cross-module VCs
- ❑ Loopbacks  $\Rightarrow$  Only PVCs
- ❑ Loopbacks  $\Rightarrow$  Max load =  $n \times$  Lowest rate

# Foreground Characteristics

- ❑ Type of foreground VCCs: PVP, SVP, **PVC**, SVC
- ❑ Foreground VCCs between ports on same/different modules/fabrics, combination
- ❑ Connection configuration: n-to-n straight, n-to-(n-1) full cross, **n-to-m partial cross** with  $m = 2, 3, 4, \dots, n-1$ , **k-to-1** with  $k=2, 3, 4, 5, 6, \dots$ ;
- ❑ Service class: **UBR**, ABR, VBR
- ❑ Arrival patterns: **equally spaced frames**, self-similar, random
- ❑ Frame length: 64 B, 1518 B, 9188 B or 64 kB, **variable**

# Motion

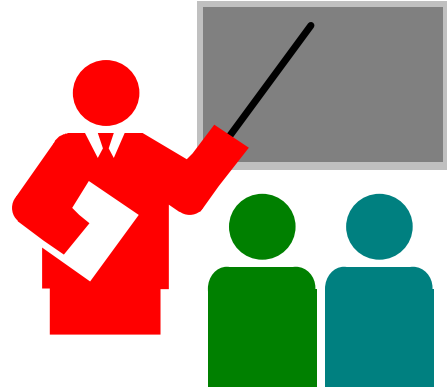

- ❑ Adopt the text of 97-0614 to replace sections 3.1 of Performance Testing Baseline Text.