

97-0832: Fairness for ABR Multipoint-to-Point Connections

**Sonia Fahmy, Raj Jain, Rohit Goyal,
and Bobby Vandalore**

Department of CIS, The Ohio State University

Sastri Kota, Lockheed Martin Telecommunications

Pradeep Samudra, Samsung Telecom America, Inc.

Contact: jain@cis.ohio-state.edu

<http://www.cis.ohio-state.edu/~jain/>



- ❑ Multipoint-to-point VCs
- ❑ Cell Interleaving Solutions
- ❑ Multipoint-to-point Algorithms
- ❑ Fairness Definitions, Examples and Comparisons
- ❑ Design and Implementation Issues

Multipoint-to-Point VCs

- ❑ A multipoint-to-point VC can have more than one concurrent sender
- ❑ Traffic at root = Σ Traffic originating from leaves
- ❑ How can bandwidth be allocated fairly?

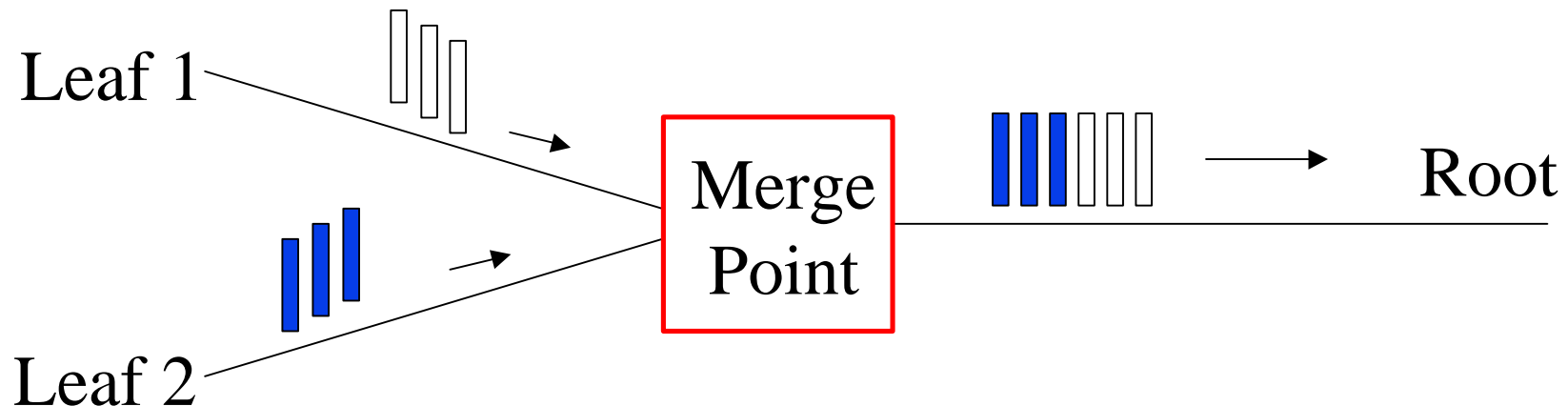

Cell Interleaving Solutions

- ❑ AAL 3/4: Limited sources, high overhead, unused.
- ❑ VC Mesh: Each source sets up a 1-to-n multicast VC. Not scalable.
- ❑ Multicast Server (MCS): Senders send to MCS, which forwards data on a 1-to-n VC. Can become overloaded.

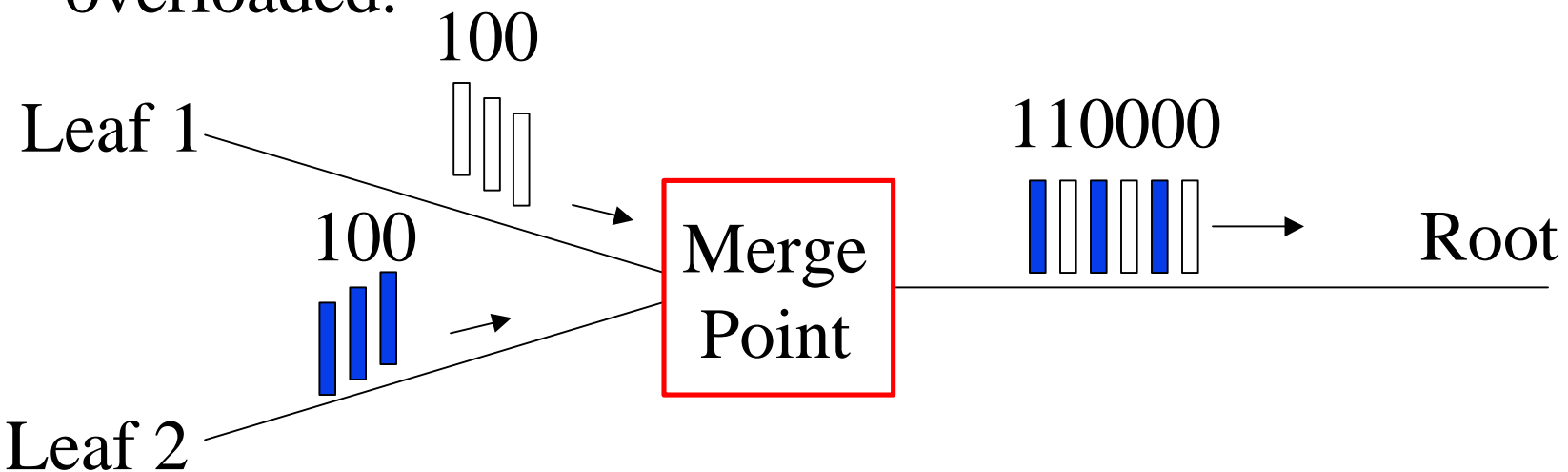

Cell Interleaving (Cont)

- ❑ Tokens: Only token holder can transmit.
High overhead and delay.
- ❑ VP merge: VCI = sender ID
VPs are used for other purposes.
- ❑ VC merge: Buffer at merge point till EOM bit = 1.
Requires memory and adds to traffic burstiness and latency.
- ❑ Sub-channel multiplexing: Use GFC.
May not scale well.

Multipoint-to-Point Algorithms

- ❑ Maintain a bit at the merge point for each flow being merged. Bit = 1 \Rightarrow FRM received from this flow after BRM sent to it.
- ❑ BRMs are duplicated and sent to flows whose bits are set, then bits are reset.

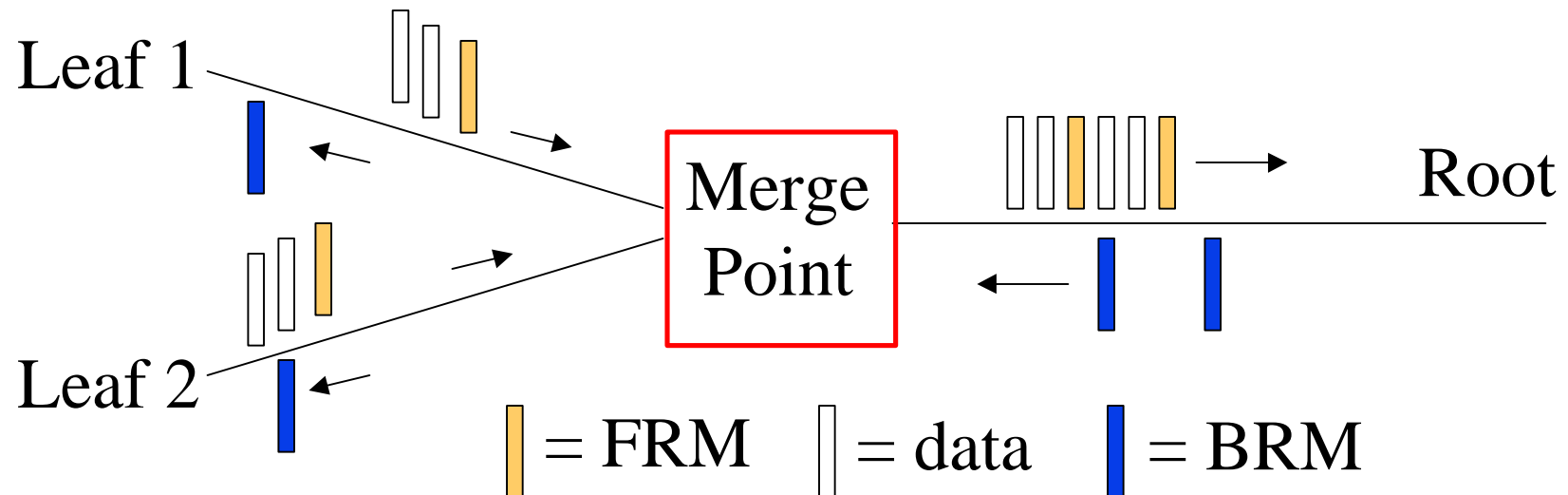

Sources, VCs, and Flows

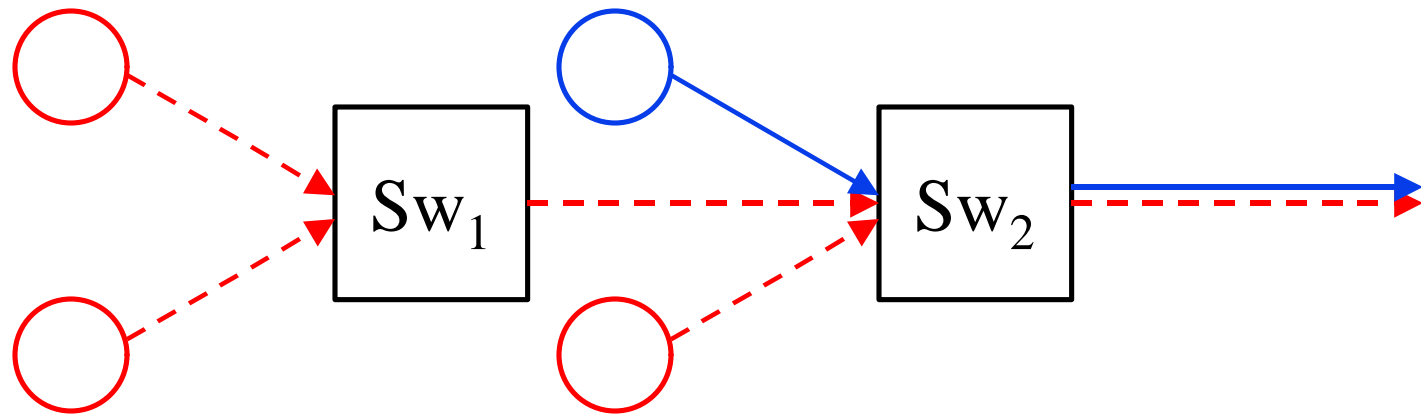

- Sw_2 has to deal with
 - Two VCs: Red and Blue
 - Four sources: Three red sources and one blue source
 - Three flows: Two red flows and one blue

Fairness Definitions

- ❑ Source-based: N-to-one connection = N one-to-one connections \Rightarrow Use max-min fairness among sources
- ❑ VC/Source-based:
 1. Allocate bandwidth fairly among VCs
 2. For each VC, allocate fairly among its sources
- ❑ Flow-based: Flow = VC coming on an input link. Switch can easily distinguish flows.
- ❑ VC/Flow-based:
 1. Allocate bandwidth fairly among VCs
 2. For each VC, allocate fairly among its flows

Example I

- How is the bandwidth of LINK₃ allocated?
- Source: $\{S_1, S_2, S_3, S_A\} \leftarrow \{37.5, 37.5, 37.5, 37.5\}$
- VC/Source: $\{S_1, S_2, S_3, S_A\} \leftarrow \{25, 25, 25, 75\}$
- Flow: $\{S_1, S_2, S_3, S_A\} \leftarrow \{25, 25, 50, 50\}$
- VC/Flow: $\{S_1, S_2, S_3, S_A\} \leftarrow \{18.75, 18.75, 37.5, 75\}$

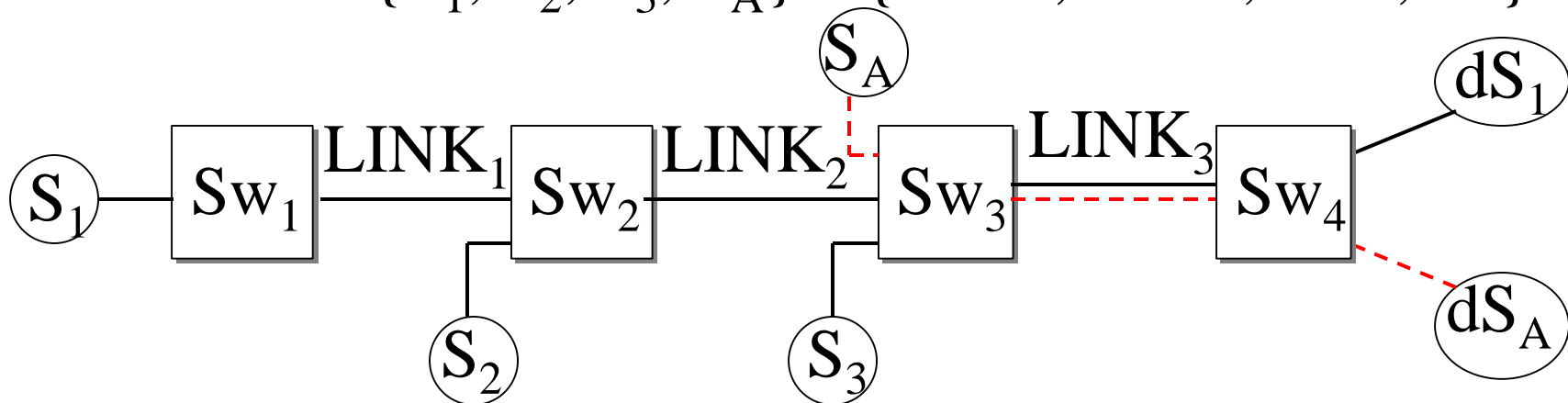

All links are 150 Mbps

Example II

- How is left-over capacity on LINK₃ allocated?
- Source: $\{S_1, S_2, S_3, S_4, S_A\} \leftarrow \{16.7, 16.7, 58.3, 58.3, 16.7\}$
- VC/Src: $\{S_1, S_2, S_3, S_4, S_A\} \leftarrow \{12.5, 12.5, 62.5, 62.5, 25\}$
- Flow: $\{S_1, S_2, S_3, S_4, S_A\} \leftarrow \{16.7, 16.7, 41.7, 75, 16.7\}$
- VC/Flow: $\{S_1, S_2, S_3, S_4, S_A\} \leftarrow \{12.5, 12.5, 50, 75, 25\}$

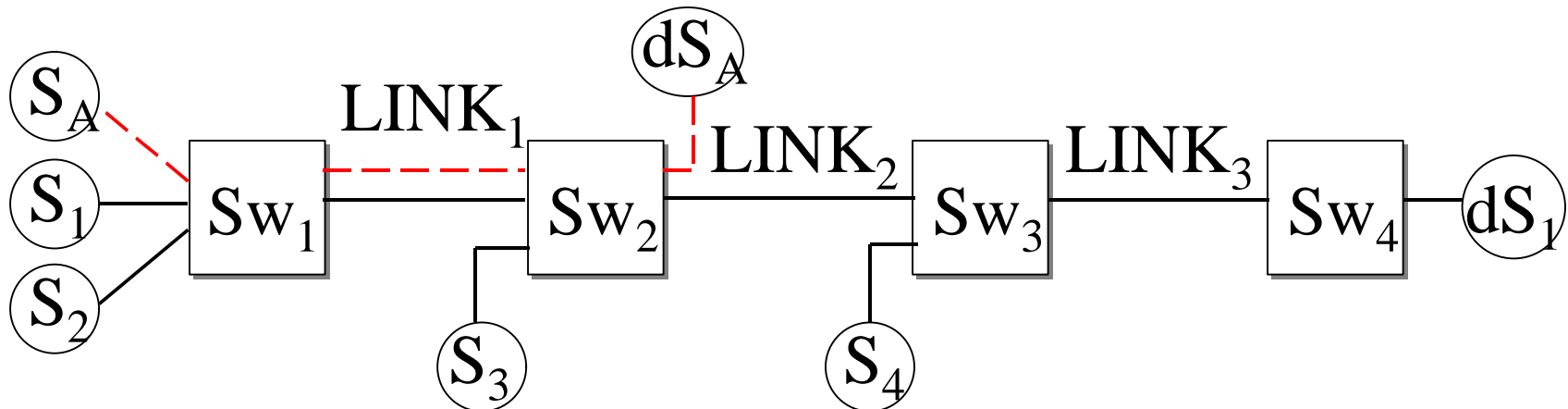

All links are 150 Mbps, except LINK₁ which is 50 Mbps

Comparison

- ❑ Source-based versus VC/source-based: In source-based, a multipoint-to-point VC with N concurrent senders is allocated N/K times the bandwidth allocated to a VC with K concurrent senders (if all senders are bottlenecked on the same link).
Is pricing based on senders or on VCs?
- ❑ Flow-based and VC/flow-based: Suffer from a “beat-down”-like problem. Sources whose flow crosses a larger number of merge points are allocated less bandwidth. But this may be acceptable in practical situations.

Design Issues

- ❑ Per-source/VC/flow accounting are equivalent for point-to-point, but different for multipoint-to-point.
 - ❑ Avoid per-source accounting (with VC merge).
 - ❑ Aggregate flow values for per-VC accounting.
- ❑ Per-source accounting is possible with VP merge.
- ❑ Using downstream rate allocations is necessary for all types except source-based (see next slide).
- ❑ Do destinations or merge points generate BRMs?
- ❑ For scalability, overhead and delays should not increase with the increase of the levels of the tree.

Implementations

- ❑ Source: Simplest to implement.
 - ❑ Avoid any per-source accounting, and estimation of rates or number of active sources.
- ❑ VC/Source: Bi-level operation, i.e., compute VC allocations, and source allocations.
 - ❑ Use downstream allocations since VC bandwidth needs to be divided among VC sources.
- ❑ Flow: Separate flows are merged into one flow
⇒ Must use downstream allocations.
- ❑ VC/Flow: Bi-level operation to estimate both (VC and flow) allocations based upon load and capacity.

Summary

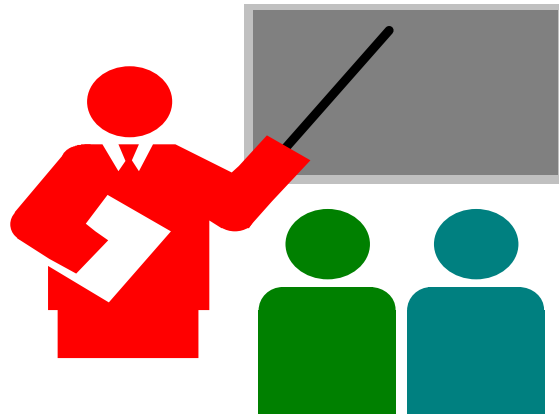

- ❑ VP merge versus VC merge
- ❑ Fairness based on sources, VCs, or flows
- ❑ Use of per-source/VC/flow accounting
- ❑ Multipoint ABR algorithms can offer tradeoffs between complexity, noise, transient response, overhead and scalability

Motion 1

- Add section 2 of 97-0832 to the baseline text of living list item 97-001

Motion 2

- Add section 7 of 97-0832 to the baseline text of living list item 97-001