

97-0615: Feedback Consolidation Algorithms for ABR Point-to-Multipoint Connections

**Sonia Fahmy, Raj Jain, Rohit Goyal,
Bobby Vandalore, Shivkumar Kalyanaraman**

Department of CIS, The Ohio State University

Sastri Kota, Lockheed Martin Telecommunications

Pradeep Samudra, Samsung Telecom America, Inc.

Contact: jain@cis.ohio-state.edu

<http://www.cis.ohio-state.edu/~jain/>



- ❑ Consolidation algorithm design
- ❑ Previous 4 algorithms
- ❑ Proposed 3 algorithms
- ❑ Simulation results
- ❑ Performance comparison

The Consolidation Operation

- Necessary to prevent feedback implosion: too many BRMs per FRM at the root

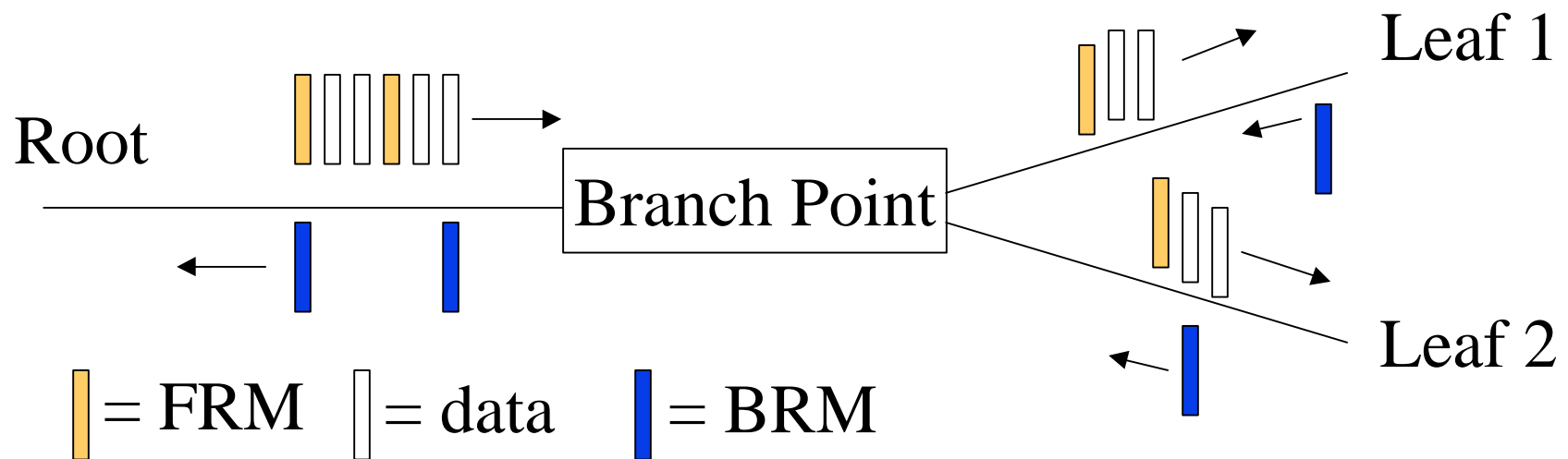

Design Issues

- ❑ Who generates BRMs: branch points or leaves?
- ❑ Wait for feedback from all branches?
- ❑ Control of ratio of BRMs to FRMs at the root?
- ❑ Ratio of BRMs to FRMs inside the network?
- ❑ Interaction of branch point and switch operations if branch point is a switch?
- ❑ Which values are stored per VC and which per branch?
- ❑ Handling non-responsive branches and timeouts?
Algorithm should not halt nor cause overload/underload
- ❑ Consolidation delay and scalability?

Scalability

- Overhead (# BRMs at root and inside network) and feedback delay should not increase with the number of leaves, branches or levels

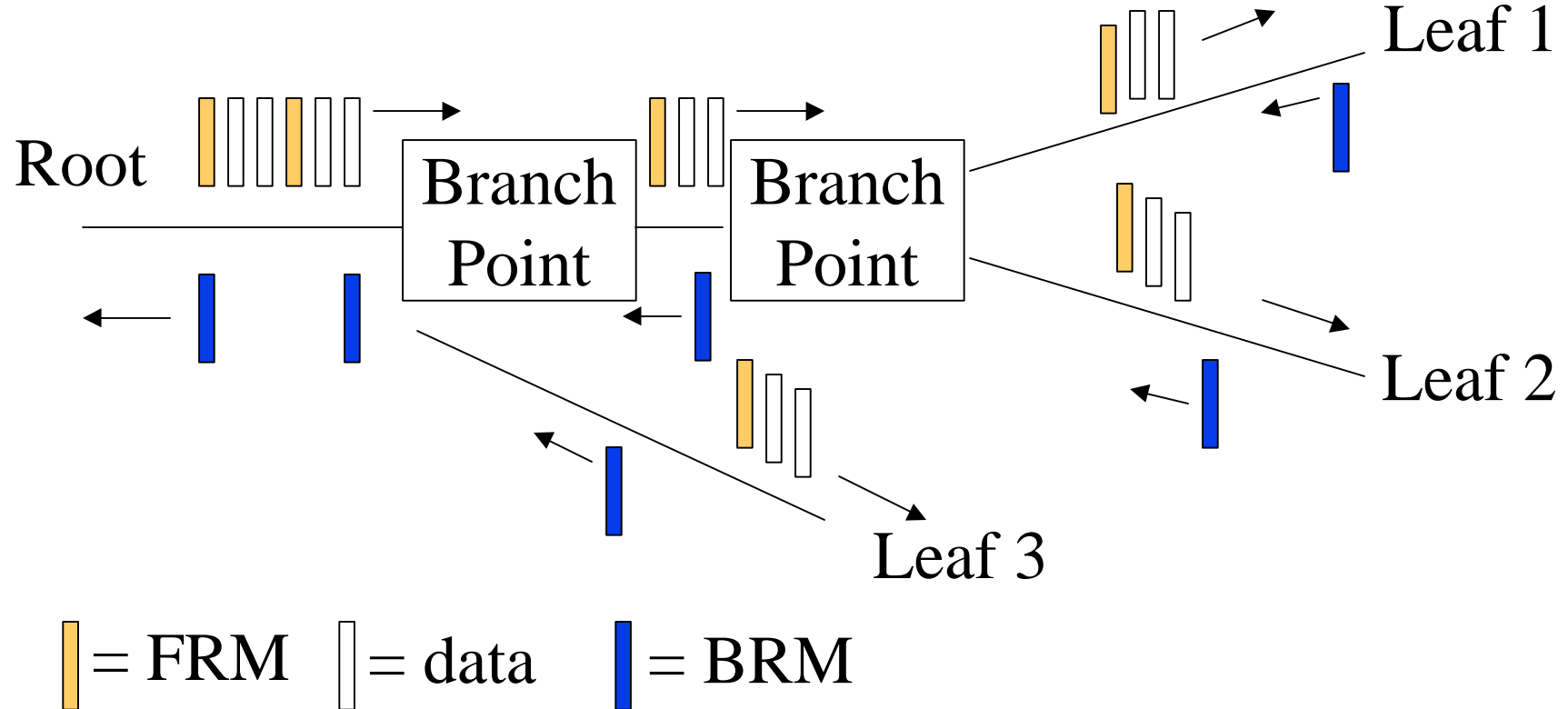

Previous Algorithms

- ❑ **Algorithm 1:** Simply turn around RM cells with the current minimum and reset minimum
- ❑ **Algorithm 2:** Turn around FRM only if at least one BRM has been received since last BRM was sent
- ❑ **Algorithm 3:** Do not turn around RM cells. Simply flag the receipt of the FRM, and return the first BRM (with modified fields) to arrive after that
- ❑ **Algorithm 4:** Wait till BRMs are received from all branches after last BRM was sent, and return the last one (with modified fields)

New Algorithms

- **Goals:**
 - Eliminate consolidation noise, but not at the expense of a very slow transient response
 - Transient response must be fast in the case of overload
- **Algorithm 5:** If the ER in the BRM is *much less* than the last ER sent (or CCR), do not wait \Rightarrow send the BRM, but do not reset the values: reset when feedback from all leaves is received
- **Problem:** BRM to FRM ratio at the root may exceed one

New Algorithms (Cont)

- ❑ **Solution \Rightarrow Algorithm 6:** For every premature RM cell, increment a counter. Decrement the counter the next time an RM giving a higher rate than the last sent is to be returned, but do not return the RM
- ❑ **Another Problem:** What if the branch point is a switch, and it is overloaded?
- ❑ **Solution \Rightarrow Algorithm 7:** When a BRM is received at the branch point, invoke the switch algorithm for the branches before checking if there is overload or not

Simulation Parameters

- ❑ Links: WAN, 155.52 Mbps (149.76 Mbps after SONET)
- ❑ Traffic: unidirectional; bursty, persistent and with and without (on/off) VBR background
- ❑ Source: Parameters selected to *maximize* ACR
Initial Cell Rate = PCR
Rate Increase Factor = 1 \Rightarrow ACR is not limited
TBE = very large
- ❑ Switch: ERICA algorithm
Target utilization = 90%
Averaging interval = $\min\{100 \text{ cells}, 1 \text{ ms}\}$

Configuration 2

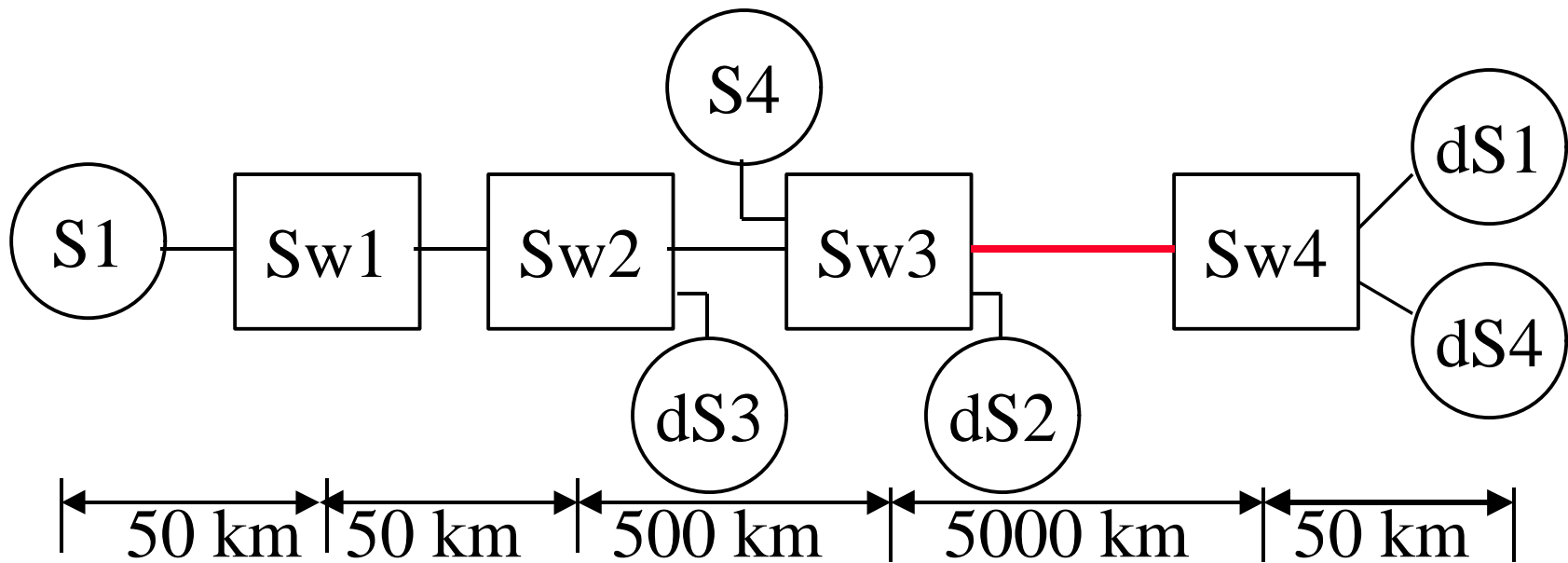

- ❑ Persistent S1 sends to dS1, dS2, dS3. S4 sends to dS4
- ❑ Chain configuration: Bottleneck link only on route to distant leaf leaves \Rightarrow all branches except longest branch (to dS1) give PCR as ER

Simulation Results 2

- ❑ Algorithms 1, 2, 3: noise, unfair, unstable
- ❑ Algorithms 4, 5, 6: no noise, but slow response
- ❑ Algorithm 7: no noise and fast response

Configuration 3

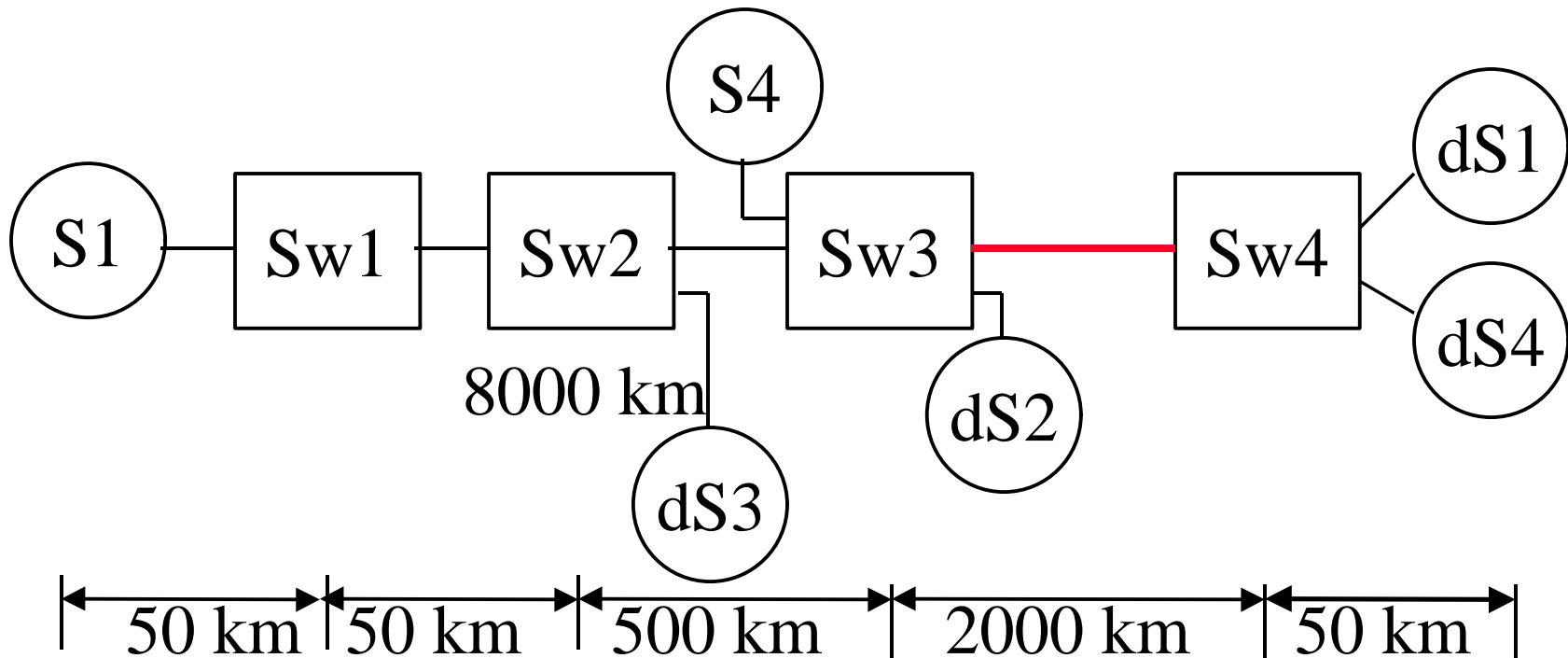

- ❑ Modified chain configuration: Bottleneck feedback is closer than other leaves. Non-bottlenecked feedback comes from far away

Simulation Results 3

- ❑ Algorithm 4: slow transient response
- ❑ Algorithms 5, 6: much faster response
- ❑ Algorithm 7: fastest
- ❑ Similar results with configurations with 10 leaves at different switches

Performance Comparison

Algorithm	1	2	3	4	5	6	7
Complexity	High	High	Low	Med	>Med	>Med	>>Med
Transient Response	Fast	Med	Med	Slow	Fast for overload		Very fast for overld
Noise	High	Med	High	Low	Low	Low	Low
BRM:FRM	1	< 1	≤ 1	≤ 1	may>1	lim=1	lim=1
Sensitivity to branch points and levels	High	High	Low	Med	>Med	Med	Med

Performance Comparison (Cont)

- ❑ Algorithms 1 and 2 do not perform well and are complex
- ❑ Algorithm 3 suffers from consolidation noise
- ❑ Algorithm 4 has a slow transient response
- ❑ Algorithms 5, 6, and especially 7 overcome this problem

Conclusions

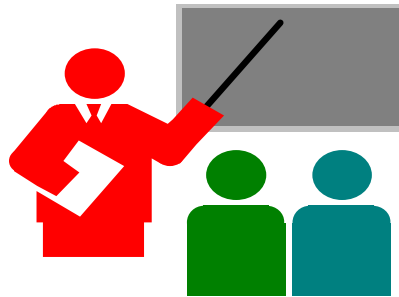

- ❑ Consolidation algorithms offer tradeoffs between complexity, transient response, noise, overhead and scalability
- ❑ The new algorithms 6 and 7 speed up the transient response, while eliminating consolidation noise and controlling overhead