

Digital Subscriber Lines and Cable Modems

Paul Sabatino, sabatino@cis.ohio-state.edu

This paper details the impact of new advances in residential broadband networking, including ADSL, HDSL, VDSL, RADSL, cable modems. History as well as future trends of these technologies are also addressed.

[Other Reports on Recent Advances in Networking](#)

[Back to Raj Jain's Home Page](#)

Table of Contents

- [1. Introduction](#)
 - [2. DSL Technologies](#)
 - [2.1 ADSL](#)
 - [2.1.1 Competing Standards](#)
 - [2.1.2 Trends](#)
 - [2.2 HDSL](#)
 - [2.3 SDSL](#)
 - [2.4 VDSL](#)
 - [2.5 RADSL](#)
 - [2.6 DSL Comparison Chart](#)
 - [3. Cable Modems](#)
 - [3.1 IEEE 802.14](#)
 - [3.2 Model of Operation](#)
 - [4. Future Trends](#)
 - [4.1 Current Trials](#)
 - [5. Summary](#)
 - [6. Glossary](#)
 - [7. References](#)
-

1. Introduction

The widespread use of the Internet and especially the World Wide Web have opened up a need for high bandwidth network services that can be brought directly to subscriber's homes. These services would provide the needed bandwidth to surf the web at lightning fast speeds and allow new technologies such as video conferencing and video on demand. Currently, Digital Subscriber Line (DSL) and Cable modem technologies look to be the most cost effective and practical methods of delivering broadband network services to the masses.

[<-- Back to Table of Contents](#)

2. DSL Technologies

Digital Subscriber Line

A Digital Subscriber Line makes use of the current copper infrastructure to supply broadband services. A DSL requires two modems, one at the phone companies end and one at the subscribers end. The use of the term modem is not entirely correct because technically a DSL modem does not do modulation/demodulation as in a modem that uses the normal telephone network. DSL's also have the added benefit of transmitting telephone services on the same set of wire as data services. DSL's common in many flavor, and are sometimes referred to as xDSL, the x standing for the specific type.

For years it has been believed that the upper limit for transmitting data on analog phone lines was 56 kb/s. This limit is set using the maximum possible bandwidth and no compression. The reason for this limit is that POTS or Plain Old Telephone Service uses the lower 4 Khz only. The limit imposed by the POTS lines does not take advantage of all the bandwidth available on copper, which is on the order of 1 Mhz. The xDSL technologies take advantage of this difference and uses the upper frequencies for data services. Previously this was not possible because of the interference that the data services would cause in the POTS band. Advances in digital signal processing have eliminated the near-end crosstalk that results from the use of the upper bandwidth for data. The new DSP technologies allow data and POTS to be transmitted on the same set of copper wires without interfering with each other. DSL technologies were initially tested for use with video on demand (VOD) and interactive television (ITV) services. Lack of a "killer application" for these services and competition from the cable TV industry in these areas forced the telephone companies to look for a different application for their technologies. With the popularity of the World Wide Web and telecommuting on the rise the DSL technologies moved to providing network and phone services to the home. Other areas where DSL technologies are targeted for are Intranet access, LAN to LAN connections, Frame Relay, ATM Network access, and leased line provisioning.

[<-- Back to Table of Contents](#)

2.1 ADSL

Asymmetric Digital Subscriber Line

The most promising of the DSL technologies is ADSL or Asymmetric Digital Subscriber Line. ADSL looks to make the most impact in residential access and the SOHO (Small Office Home Office) market. Just like the name implies ADSL is asymmetric, meaning that the downstream bandwidth is higher than the upstream bandwidth. Downstream refers to traffic in the direction towards the subscriber, and upstream refers to data sent from the subscriber back to the network. This is done because of the kinds of traffic that ADSL is designed to carry. Asymmetry is used to increase the downstream bandwidth. This works because all of the downstream signals can be of the same amplitude thus eliminating crosstalk between downstream channels. Upstream signals would have to put up with more interference because the amplitude of the upstream signals would be of smaller amplitude because they are originating from different distances. The asymmetric nature of ADSL lends itself well to applications like the web and client server applications.

To achieve the asymmetry ADSL divides its bandwidth into four classes of transport.

- higher bandwidth simplex channel
- lower bandwidth duplex channel
- duplex control channel
- POTS channel

Transmission on the high bandwidth simplex channel and the lower bandwidth duplex channel do not interfere in any way with the POTS channel. So ADSL can carry both data and POTS on the same medium, which makes it ideal for residential and small office use.

ADSL bandwidth is currently standardized by ANSI (American National Standards Institute). Tables 1 and 2 detail the four transport classes which are based on multiples of T-1 (1.5 Mb/s) downstream bandwidth. There are also three more classes that are based on the European E-1 (2.0 Mb/s) standard which is shown in the second chart. These classes are all based on the maximum bandwidth available on each channel. The actual rates depend on factors such as wire gauge, local loop length, and line condition. In this case, the local loop length is the distance from the central office to the subscriber.

ADSL Transport Classes (T-1 based multiples)*

Class	1	2	3	4
Downstream simplex channel	6.144 Mb/s	4.608 Mb/s	3.072 Mb/s	1.536 Mb/s
Upstream duplex channel	640 kb/s 576 kb/s of usable bandwidth	608 kb/s 544 kb/s of usable bandwidth	608 kb/s 544 kb/s of usable bandwidth	176 kb/s 160 kb/s of usable bandwidth
Control channel	64 kb/s	64 kb/s	64 kb/s	16 kb/s
POTS channel	64 kb/s	64 kb/s	64 kb/s	64 kb/s

Chart 1

ADSL Transport Classes (E-1 based multiples)*

Class	2M1	2M2	2M3
Downstream simplex channel	6.144 Mb/s	4.096 Mb/s	2.048 Mb/s
Upstream duplex channel	640 kb/s	608 kb/s	176 kb/s
Control channel	64 kb/s	64 kb/s	16 kb/s
POTS channel	64 kb/s	64 kb/s	64 kb/s

Chart 2

*Table information from *IEEE Network Jan./Feb. 1997*

2.1.1 Competing Standards

One issue yet to be resolved with ADSL is the debate between CAP (Carrierless Amplitude Modulation) and DMT (Discrete Multitone) line code standards. DMT has been standardized by ANSI, but currently products using CAP have been released by various companies. Different companies support different standards and neither of them has become a de facto standard. CAP technologies have been quicker to get to market but DMT is gaining. The main drawback with DMT is that it has been expensive to deploy up until recently. Both methods have their advantages. CAP is a single carrier modulation technique that uses three frequency ranges. CAP uses 900 Mhz for downstream data, 75 Mhz for upstream data, and 4 KHz for POTS service. CAP takes the data channels and treats them like one big pipe on which to send data. DMT is different in that it breaks the data transmission channels into 256 subchannels and then selects the best ones on which to send its data. DMT fits better in to a [RADSL](#) or Rate Adaptive DSL, scheme due to the fact that it has that ability to select channels that have lower levels of interference on them. CAP generally provides 1.5 Mb/s downstream and 64 kb/s up stream. In contrast DMT transmits 6 Mb/s downstream and 640 kb/s upstream. DMT is not without disadvantages, the DMT equipment requires more power and therefore operates at higher temperature which limits the number of ADSL / DMT modems that can be stacked together at a central office.

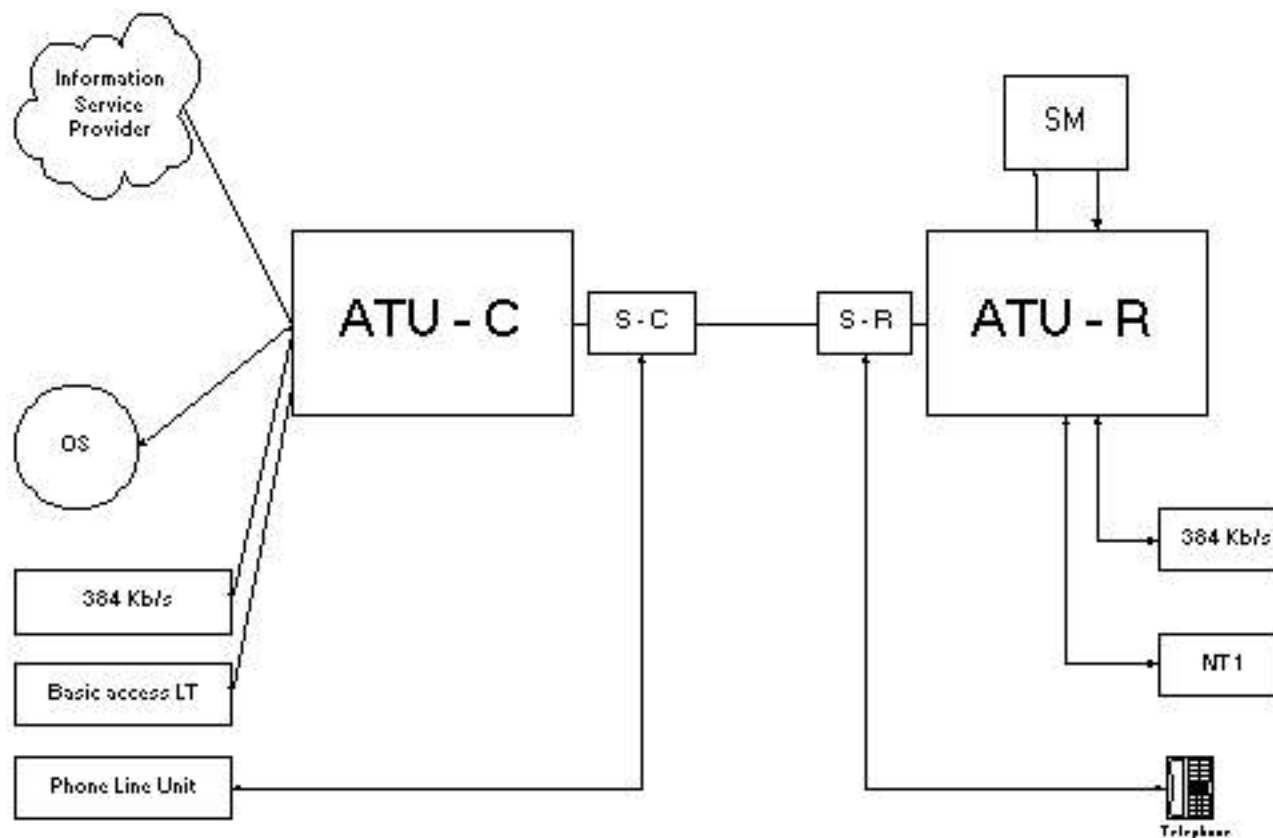

Figure 1: Basic ADSL system

The basic ADSL model is given in [figure 1](#) . The -C and -R designations are given to the terminal equipment on the Central Office and the remote end respectively. The S-C and the S-R units split the POTS signal in and out of the ADSL signal.

2.1.2 Trends

Of all the DSL technologies ADSL is being tested the most right now. Widespread deployment is not far off.

To help this along companies are making complete DMT based ADSL transceivers on a chips at lower costs than the chip sets previously used. Some of those chips also incorporate Ethernet serial transceivers in them to make it easier to interface with current LAN technologies.

There is also some debate between HDSL or High-data-rate DSL and ADSL. HDSL provides a symmetric data pathway at 1.544 Mb/s which matches the speed of today's T-1's. HDSL has been around longer and is currently being used to effectively provision local access to T-1's. HDSL has its place in that market while ADSL can provide a better service to homes and small business that use the web and client server technologies.

[<-- Back to Table of Contents](#)

2.2 HDSL

High-data-rate Digital Subscriber Line

The most common DSL deployed today is HDSL. HDSL is mostly used to provision other services by

telephone companies. HDSL symmetrically delivers 1.544 Mb/s over two sets of copper twisted pair. Which is the same rate as a T-1 type connection. This allows telco's (short for telephone companies) to use HDSL to deliver T-1 services. HDSL's operating range is about 12,000 feet, and it is possible to extend that by using repeaters along the line to the customer. HDSL is mostly used to deploy PBX network connections , interexchange POP's (Point Of Presence), and directly connecting servers to the Internet.

2.3 SDSL

Single-line Digital Subscriber Line also know as Symmetric Digital Subscriber Line

Similar to HDSL, SDSL delivers the same 1.544 Mb/s, but it does it on a single set of twisted pair of copper. This limits SDSL's reach to 10,000 feet. SDSL could take hold in niche markets like residential video conferencing or connecting LAN's over short distances.

[<-- Back to Table of Contents](#)

2.4 VDSL

Very-high-rate Digital Subscriber Line

VDSL technology operates on a single set of copper twisted pair, and delivers data in the range of 13 Mb/s to 52 Mb/s. This high bandwidth does not come without a price, the range of VDSL is limited to between 1,000 and 4,500 feet. The VDSL standard is still in the works but there are already applications for the technology. One use for it is in getting high data rate services from the telephone companies central office to the subscriber via a FTTN (Fiber To The Neighborhood) network.. FTTN encompasses the Fiber To The Curb technologies and uses VDSL as the customers connection to the telephone companies fiber based network.

VDSL would be used to connect premises distribution networks to the Optical Network Unit or ONU. The optical network unit is in turn connected via fiber optical line to the telco's central office.

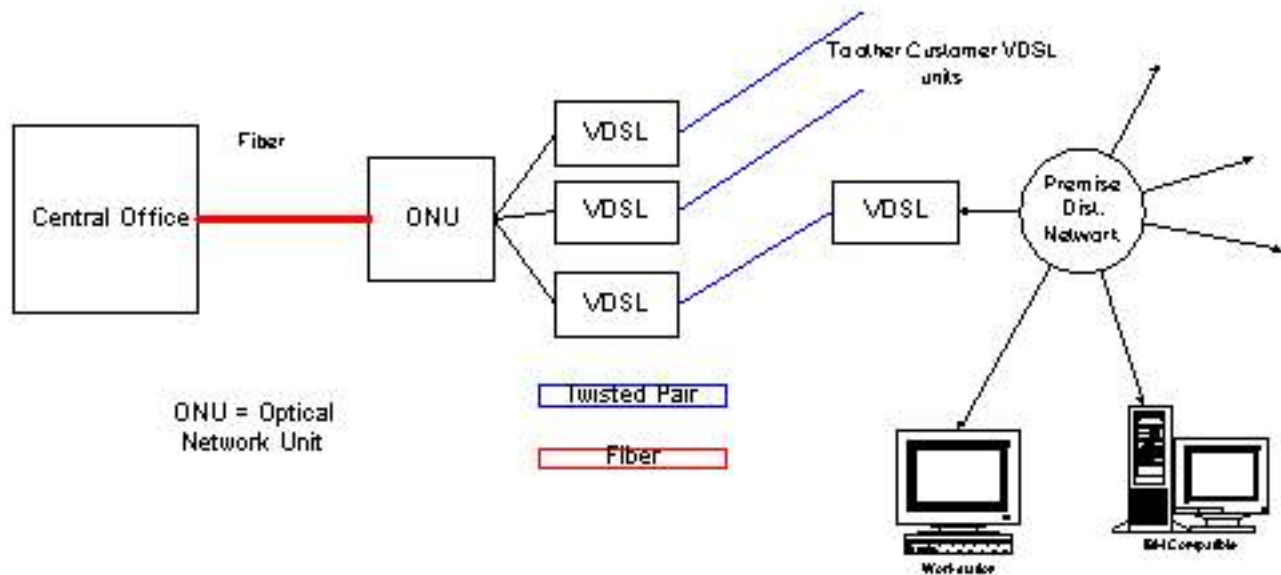

Figure 2: A typical use of VDSL

Figure 2 shows how VDSL might be used to bring data services from an ONU to the customers premises distribution network. The fiber links are shown in red and the twisted pair links are shown in blue.

Since VDSL is still in discussion right now there are no solid standards but some reachable goals have been set in an early draft by the ADSL Forum. Data rates have been projected as multiples of SONET and SDH. These speeds have been chosen because of proposed use of VDSL as a solution for delivering fiber type bandwidth to customers over copper.

Proposed Data rates for VDSL

Data rate	Range in feet	Range in meters
12.96 - 13.8 Mb/s	4500 ft	1500 m
25.92 - 27.6 Mb/s	3000 ft	1000 m
51.84 - 55.2 Mb/s	1000 ft	300 m

Chart 3

2.5 RADSL

Rate Adaptive Digital Subscriber Line

RADSL is derived from ADSL technologies with some added features. RADSL automatically adjusts line speed based on the condition of the line. In areas where there is a large variance in the distance between the central office and the subscribers RADSL helps to provide a more consistent service for its subscribers by taking the uncertainties of line conditions out of the equation when setting up a DSL connection. RADSL can adjust line speed based on the gauge of the wire, the distance between

subscriber and the central office, and the condition of the line. It also takes care of fluctuations that the weather can induce into the line.

[<-- Back to Table of Contents](#)

2.6 Comparison of DSL Technologies

DSL Comparison

DSL	Upstream Bandwidth	Downstream Bandwidth	Range	Media	Symmetry
ADSL	16 kb/s to 640 kb/s	1.5 Mb/s to 9 Mb/s *	18,000 feet	Single twisted pair	Asymmetric
HDSL	1.544 Mb/s	1.544 Mb/s	12,000 feet	Two twisted pairs	Symmetric
SDSL	1.544 Mb/s	1.544 Mb/s	10,000 feet	Single twisted pair	Symmetric
RADSL	varies with in ADSL range	varies with in ADSL range	18,000 feet	Single twisted pair	Asymmetric
VDSL	13 Mb/s - 52 Mb/s	1.6 Mb/s to 2.3 Mb/s	1,000 - 4,500 feet	Single twisted pair	Both

Chart 4

* New technologies have reported higher rates.

[<-- Back to Table of Contents](#)

3. Cable Modems

Broadband networking using a modification of today's CATV infrastructure.

Internet growth and the convergence of the television with the computer has led cable companies to develop methods of delivering broadband services to residential customers. Currently there are approximately 63 million households in the United States that have cable TV. That number is projected to grow to near 70 million by the year 2000. It is estimated that about 40% of those households are in a cable system that, with modest upgrade to the backbone equipment, will be able to support two way cable network traffic. This opens up a huge market for cable companies. Cable modem bandwidth varies with the manufacturer of the equipment and the network design from 96 kb/s up to 10 Mb/s. Cable networks are based on modified LAN technologies and the Hybrid Fiber Coax (HFC) network, which which accounts for the backbone of most modern cable systems. The one major drawback to this strategy is that these networks are all based on media sharing. This only presents a problem when the network is

under heavy use, but with proper network design overloading can easily be avoided.

3.1 Basic Model of Operation

Cable modems have been designed to transparently carry data traffic through a combination of HFC and or coax network then connect to varying types of data networks. Beyond transparently carrying IP traffic a cable modem network must also be capable of filtering certain types of traffic. The cable network must be able to filter out all local LAN broadcasts, except for DHCP traffic which is used to configure network hosts, and ARP packets which are needed for address resolution. Also ICMP message must be passed over the network for the proper use of the IP protocol. A specification for the cable modem to customer network equipment has been established by a group of companies and maintained by [CableLabs](#), a Denver based R&D Consortium. Some of the companies in this working group are Comcast, Continental Cablevision, Cox Communications, Rogers Cablesystems Ltd, Time Warner Cable, and Tele-Communications Inc. They also set specifications for the network termination equipment that interface the cable network and other data networks. This specification specifies interfaces for several different kinds of data networks some of those are ATM, FDDI, Ethernet and IEEE 802. protocols.

3.2 IEEE 802.14

Logical Reference Model

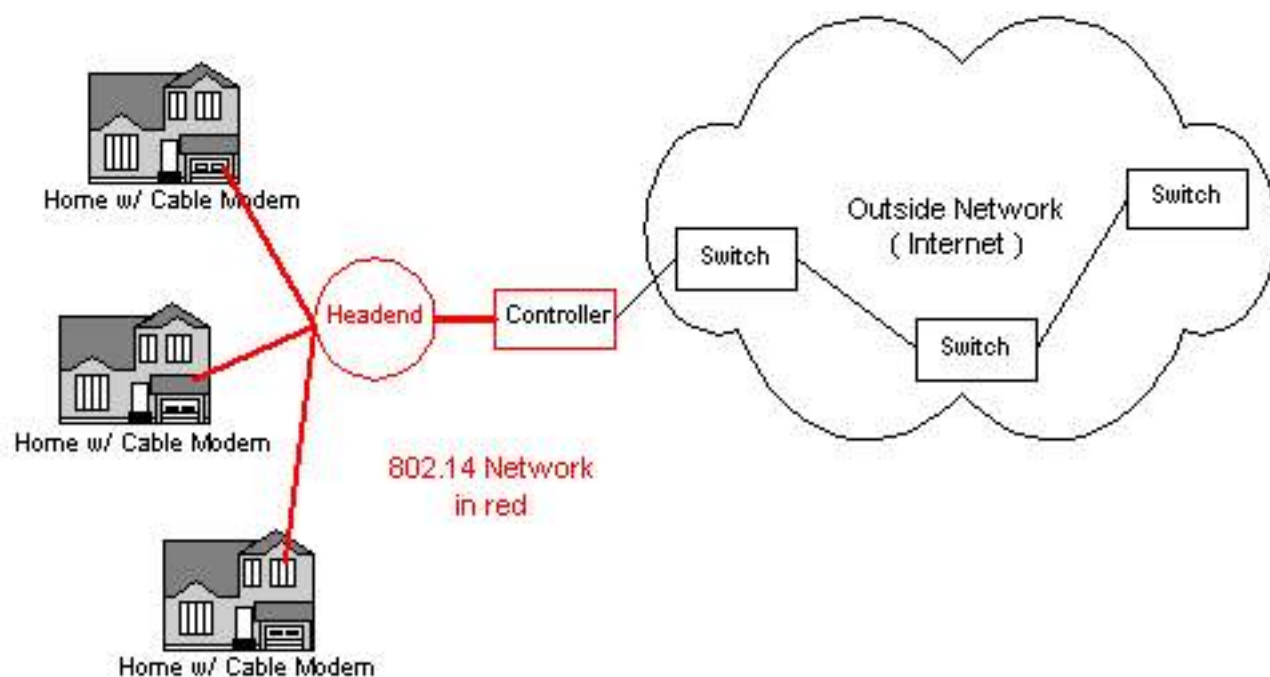

Figure 3: An 802.14 network is shown in red

The model shown in figure 3 will be implemented over HFC and TV cable coax networks. The topology of today's most common cable TV system is tree and branch or a collection of branches, where

all signals originate at the head and are propagated down to the subscribers. The IEEE 802.14 standard provides for several different topologies, coaxial cable TV network, fiber to the serving area, regional hub / passive coaxial network, and hybrid fiber coax networks. IEEE 802.14 also makes certain network inter-connectivity requirements. Inter-network communication on an 802.14 network is when a host transmits upstream to the headend and then on to another 802.14 network. If the sender and receiver are on the same branch of the network then the upstream traffic can be broadcast and all hosts on that network will receive it. In the event that the destination is not on the same network the headend can forward it on the to correct 802.14 network. This brings in the need for inter-headend communications. This is accomplished by linking 802.14 headends together using point to point SONET links, ATM switches, IEEE 802.6 shared buses, or SONET rings. The 802.14 MAC layer is designed to be a fair and open protocol layer. Traffic control is used to provide fair access to network services. The traffic control services to be offered on an 802.14 network are deadlock avoidance and congestion control. Call admittance algorithms are used to reject calls after the constant bit rate bandwidth has been exceeded. Support for asymmetry is also included in the 802.14 standard as a way to better support traffic that requires greater bandwidth in one direction, like VOD, POTS, and video telephony. For these types of applications to work some methods of synchronous communications are needed, constant bit rate and variable bit rate services provide this. These services are synchronous in that periodic access to the medium needs to be guaranteed in order to maintain quality of service.

[<-- Back to Table of Contents](#)

4. Trends

Trends in residential broadband networking

The front runners in the race to bring high bandwidth services to residential, and small business customers are ADSL and cable modem technologies. Competing standards and slow to develop new technologies have kept the race slow but development looks to speed up in the next few years. According to Jesse Bert, editorial director for ZDNet's AnchorDesk, by the year 2000 high speed Internet access to the home will break down like this:

- 1% VBI (Vertical Blanking Interval)
- 1 % Wireless
- 2% Satellite
- 4% ISDN
- 4% DSL
- 8% Cable Modem
- 80% analog modems

These are just estimates and in reality other factors will probably push broadband services into mainstream markets. Consumers of these services will demand more bandwidth and probably accelerate the deployment of DSL and cable modems due to the fact that part of the infrastructure for these

technologies is in place now and it's just a matter of finding a economically safe way to deploy them to the masses. The [Pelorus Group](#) reported in a report called "The future of ADSL", that ISP's may be the first to deploy ADSL as a method of residential Internet access. This is because ISP's will be able to use their already strong connection to the Internet to bundle that service into an complete ADSL solution for high bandwidth access. In the same report it is also predicted that DSL revenues in the U.S. will reach \$1.5 billion, by the year 2001.

4.1 Current Trials

The @Home service owned by a group of cable companies has cable modem services available in Fremont, Calif., and will soon roll-out service in Sunnyvale, Calif., Arlington, Heights, Ill, and West Hartford, Conn. Continental Cablevision is expanding their current service in the Boston area and also plans to offer cable modem service in Chicago, Detroit, Los Angeles, and Jacksonville. Time Warner is now providing it's RoadRunner service to customers in the Akron, Canton area and select markets in New York state. Time Warner also plans to have services in Columbus, Ohio, Portland, Maine, and San Diego this winter.

ADSL trials are less aggressive at this time due to the CAP vs. DMT line code standard debate. When one of these technologies gets widespread use the industry will follow that and go with a single standard rather than try and provide interoperability between the two. Currently GTE and Southwestern Bell are performing technical trials. LEC, an Anchorage, Alaska based ISP and a Chicago ISP have begun offer ADSL services on a small-scale in there areas. One hurdle that ADSL needs to overcome is the cost of the modems. Costs of a single line installation can run up near \$2000, telephone companies predict that when the cost can be driven down to around \$500 per line that ADSL will become more marketable.

[<-- Back to Table of Contents](#)

5. Summary

Spurned by Internet growth and the convergence of television with the personal computer, high bandwidth data services are soon to in homes everywhere. DSL and cable modems look to be an economically promising alternative to today's current 56 kb/s modems that promise to bring much higher data rates to the home. Two industries race for the business of the data hunger consumer, the telephone companies and cable companies. Cable modems look to make use of the high bandwidth coax and hybrid fiber networks already used to provided television service, while the phone companies use their existing copper and more recent transition to digital networks as a way to leverage their current infrastructure to meet the high speed demands of their customers. In the near future broadband services while may become as commonplace and nessecary as today's telephone service.

6. Glossary

Terms used in this report.

ADSL - Asymmetric Digital Subscriber Line. DSL with higher bandwidth in one direction than the other.

ANSI - American National Standards Institution.

ATM - Asynchronous Transfer Mode. Digital switched network, transfers in fixed length 53 byte cells.

ATU-C - ADSL Terminal Unit Central Office. Terminal nearer the central office or remote network node.

ATU-R - ADSL Terminal Unit Remote. ADSL terminal nearer to the subscriber.

CAP - Carrierless Amplitude Modulation/Phase Modulation. A possible technology used in ADSL.

Current standards put

emphasis on DMT technology.

DMT - Discrete Multitone. A version of multi-carrier modulation that allows allocation of payload data bits and transmitter

power among more than one subchannel depending on loss, and interference among each subchannel. A candidate

technology for ADSL.

Drop Wire - Last part of the loop connecting distribution cable to the customer premises.

DS1 - Digital Signal 1 : 1.544 Mb/s with a payload of 1.536 Mb/s bi-directional.

DS2 - Digital Signal 2 : 6.312 Mb/s , which can transport 4 DS1's asynchronously.

ECH - Echo Canceler with hybrid. used in DSL and HDSL systems.

FTTC - Fiber To The Curb. Fiber optic lines that run to a remote electronics node close to the subscribers location.

FTTH - Fiber To The Home. Fiber optic line that run to the subscribers home.

POTS - Plain Old Telephone Service. Telephone service as we know it today.

RBOCS - Regional Bell Operating Companies. Local exchange carriers.

RFI - Radio frequency interference.

SONET - Synchronous Optical Network. Synchronous multiplexing for fiber optical transport. Supports synchronous as

well as asynchronous payloads. Signals come in multiples of OC-1, 51.84 Mb/s

STB - Set Top Box. Performs decoding for broadband services. Examples are devices that connect the network to a TV.

telco - Short for telephone company.

VDSL - Very-high-rate Digital Subscriber Line. Capable of transporting 50 Mb/s payload or greater. Asymmetric

or Symmetric

[<-- Back to Table of Contents](#)

7. References

References used in producing this report. In order of usefulness.

DSL Technologies

- Marlis Humphrey, John Freeman, Paradyne Corp., "How xDSL supports Broadband Services to the Home", IEEE Network Jan./Feb 1997 **Notes:** Very good, sources for information in charts 1 and 2
- ADSL Forum, "ADSL Forum System Reference Model", http://www.adsl.com/adsl_reference_model.html
- ADSL Forum, "ADSL Tutorial", http://www.adsl.com/adsl_tutorial.html
- tele.com, "DSL, from A to V", <http://www.teledotcom.com/1096/features/tdc1096coverstory1.html>
- Philip Kyees, Ronald C McConnell, Kamran Sistanizadeh, "ADSL: A New Twisted-Pair Access to the Information Highway", IEEE Communications Magazine, April 1995
- Carol Wilson, "Can Two ADSL Versions Co-Mingle?", Oct. 9, 1996, <http://www.zdnet.com/intweek/daily/961009c.html>
- Angela Littwin, "ADSL: Ready for Prime Time?", Telecommunications, Dec. 1996
- Arielle Emmett, "Motorola plays ADSL chip, CopperGold bets on single-chip transceiver", America's Network, Dec. 1, 1996, <http://www.americasnetwork.com/>
- ADSL Forum, "VDSL Tutorial, Fiber-Copper Access to the Information Highway", http://www.adsl.com/vdsl_tutorial.html

Cable Modems

- IEEE 802.14 working group, "Standard Protocol for Cable-TV based Broadband Communication Network", <http://>
- "Data Over Cable Interface Specifications - Cable Modem to Customer Premise Equipment Interface Specification", <http://www.cablelabs.com>
- CableLabs, "Cable Data Modems - A primer for non-technical readers", <http://www.cablelabs.com>
- "Data Over Cable Interface Specifications - Cable Modem Termination System Network side Interface Specification", <http://www.cablelabs.com>
- Carl Weinschenk, "The Great Wired Hope", <http://www.teledotcom.com/1296/features/tdc1296modem.html>

Trends

- David Kopf, "Striking while the Copper is HOT", America's Network,
- Jesse Berst, "The Future of Fast Access", http://www4.zdnet.com/anchordesk/story/story_1129.html
- ZDNet - ISP Zone, "ISP's May Emerge As Largest Providers Of DSL Services", <http://www8.zdnet.com/zdimag/ispzone/news/199707/23/news3.html>

- The Pelorus Group, "The Future of ADSL", <http://www.pelorus-group.com>

Other useful references

- Dan Kegel's ADSL Page, <http://www.alumni.caltech.edu/~dank/isdn/adsl.html>
- Cable Modem Resources on the Web, <http://rpcp.mit.edu/~gingold/cable/>
- Daniel Minoli, "Video Dialtone Technology", McGraw-Hill Inc. 1995 **Notes:** Chapter 4 is a good primer on Cable TV Technology.

[<-- Contents](#)

Last Modified 8/14/87