

# Wireless Data Networking

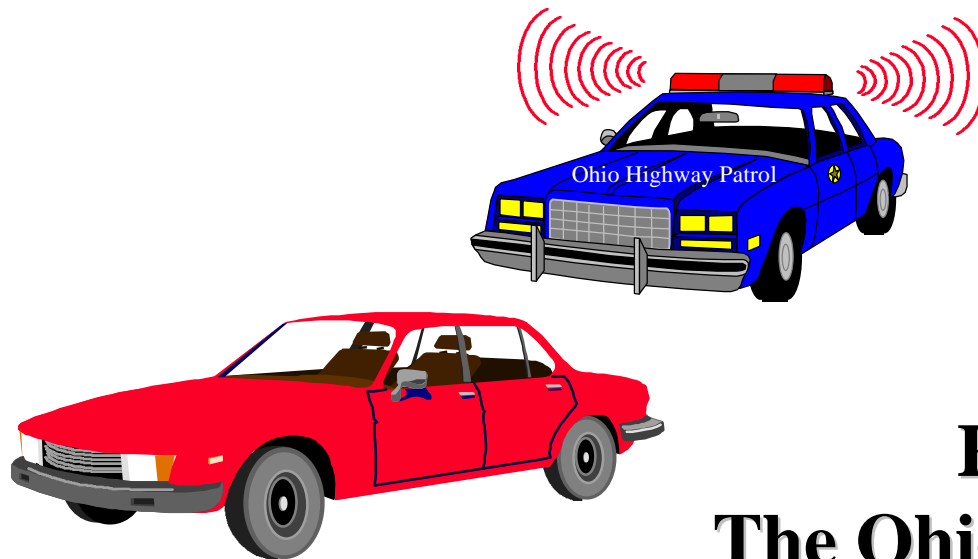

**Raj Jain**  
**The Ohio State University**  
**Columbus, OH 43210**

Handouts: <http://www.cis.ohio-state.edu/~jain/cis788-97/>

Email questions to [mbone@netlab.ohio-state.edu](mailto:mbone@netlab.ohio-state.edu)



- ❑ Spread Spectrum
- ❑ Wireless wide area networks: CDPD and Metricom
- ❑ Wireless local area networks
- ❑ Wireless LAN standard: IEEE 802.11, Hiperlan
- ❑ Wireless ATM
- ❑ Mobile IP

Note: wireless **phone** services and standards not covered.

# Mobile vs Wireless

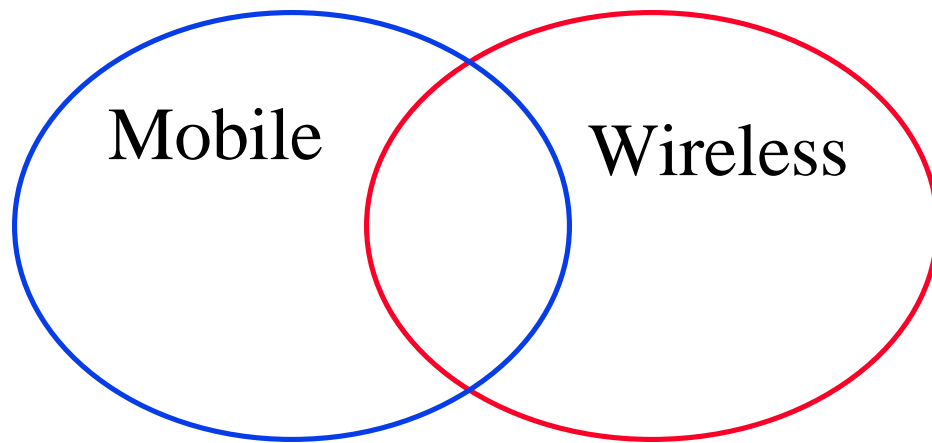

- ❑ Mobile vs Stationary
- ❑ Wireless vs Wired
- ❑ Wireless  $\Rightarrow$  media sharing issues
- ❑ Mobile  $\Rightarrow$  routing, addressing issues

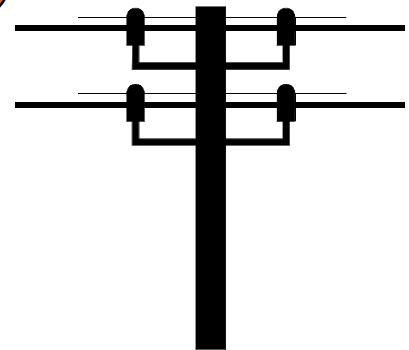

# Frequency Hopping Spread Spectrum

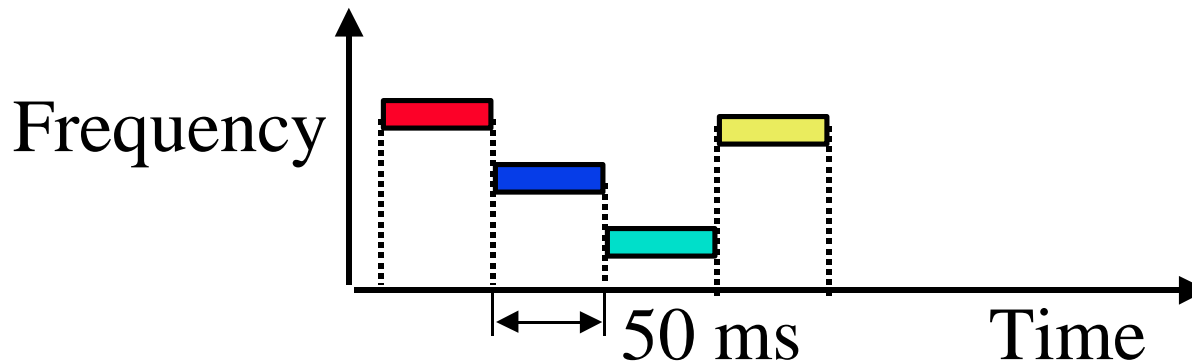

- ❑ Pseudo-random frequency hopping
- ❑ Spreads the power over a wide spectrum  
⇒ Spread Spectrum
- ❑ Developed initially for military
- ❑ Patented by actress Hedy Lamarr
- ❑ Narrowband interference can't jam

# Spectrum

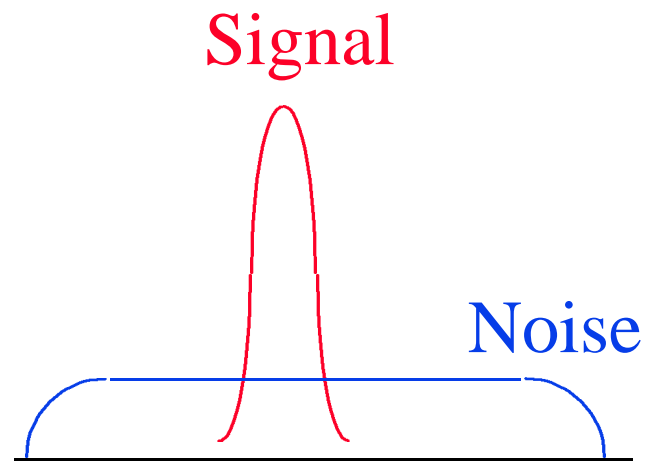

(a) Normal

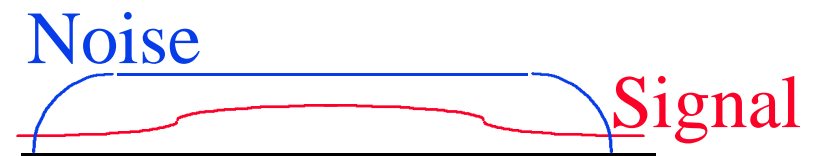

(b) Frequency Hopping

# Direct-Sequence Spread Spectrum

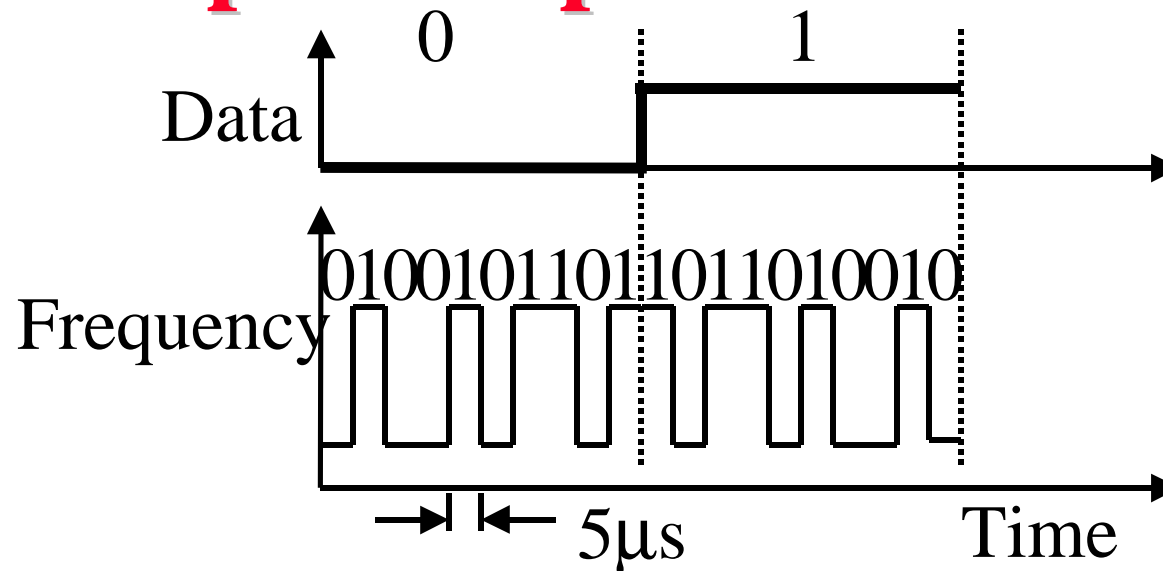

- ❑ Spreading factor = Code bits/data bit, 10-100 commercial (Min 10 by FCC), 10,000 for military
- ❑ Signal bandwidth  $>10 \times$  data bandwidth
- ❑ Code sequence synchronization
- ❑ Correlation between codes  $\Rightarrow$  Interference  $\Rightarrow$  Orthogonal

# DS Spectrum

Time Domain

Frequency Domain

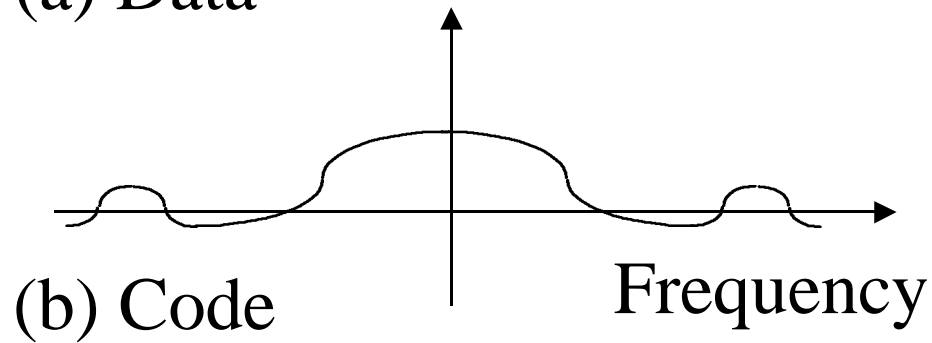
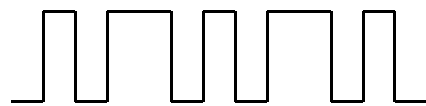
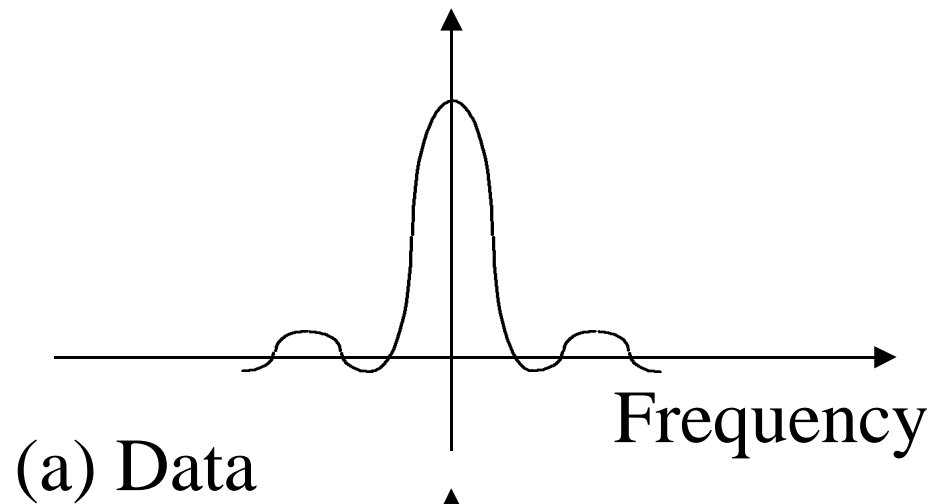
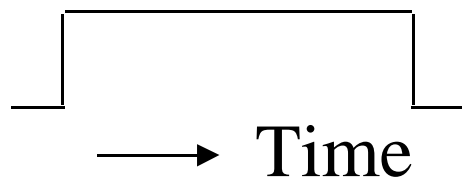

# Wireless WAN Services

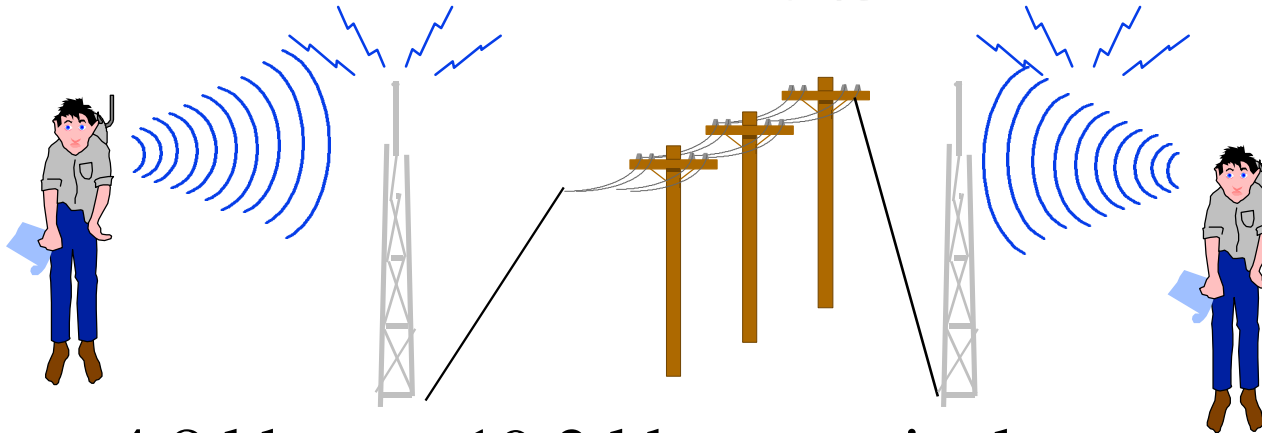

- ❑ 4.8 kbps to 19.2 kbps nominal
- ❑ Throughput 2 to 8 kbps
- ❑ Wired backbone using leased lines
- ❑ Packetized short transmission
- ❑ Email, stock quotes, weather
- ❑ Options: ARDIS, RAM Mobile Data, Cellular, Cellular Digital Packet Data (CDPD), and Metricom

# Cellular Digital Packet Data (CDPD)

- ❑ Originally named “Celluplan” by IBM
- ❑ Allows data to use idle cellular channels
- ❑ Data hops from one channel to next as the channels become busy or idle

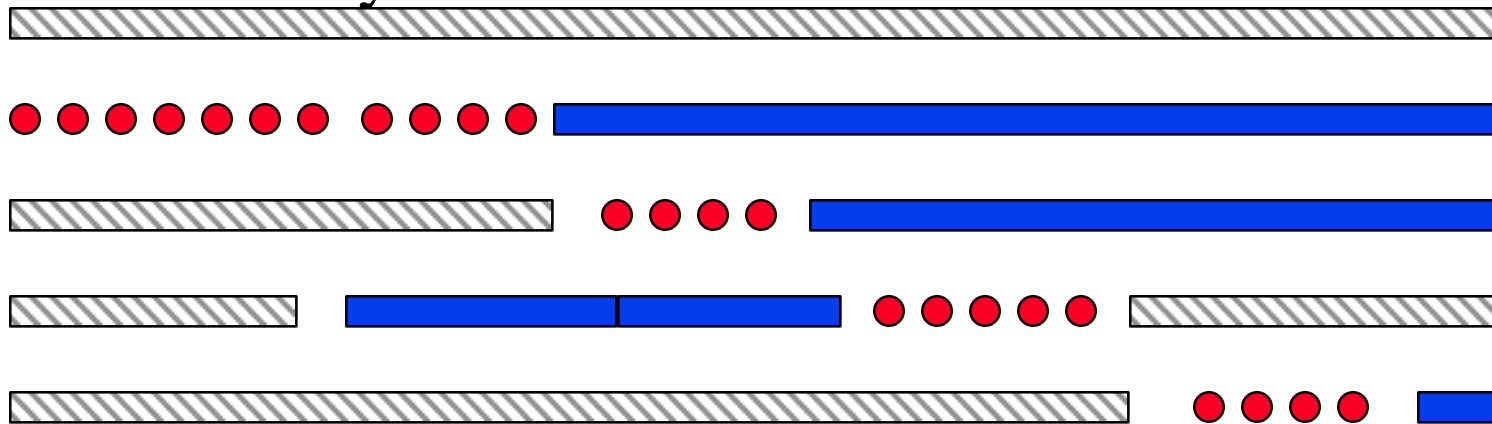

 Voice Call                       Data packets  
 Idle Channel

# CDPD

- ❑ Backed by 9 major service providers
- ❑ Nationwide cellular packet data service
- ❑ Connectionless and connection-oriented service
  - Connectionless  $\Rightarrow$  No ack, no guarantees
  - Connection-oriented  $\Rightarrow$  reliable delivery, sequencing, flow control
- ❑ Point-to-point and multipoint connections
- ❑ Quickly hops-off a channel grabbed by cellular system. Currently, dedicated channels.

# Metricom

- ❑ Spread-Spectrum in 902-928 MHz band
- ❑ In-building, campus, and metropolitan area networking
- ❑ Nearby units can communicate directly.
- ❑ If the intended destination is not directly reachable, go via a “node” through the network. Up to 56 kbps.
- ❑ Nodes are cheap (less than \$1,000)
- ❑ Flat monthly rate based on speed only

Ref: <http://www.metricom.com/ricohom.html>

# Wireless LANs

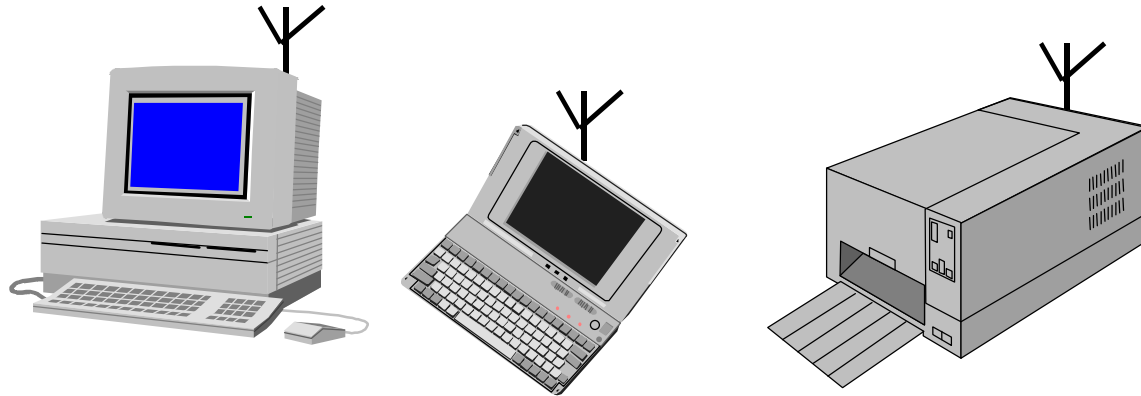

- ❑ IR  $\Rightarrow$  Line of sight, short range, indoors
- ❑ RF  $\Rightarrow$  Need license
- ❑ Spread-Spectrum: Resistance to interference

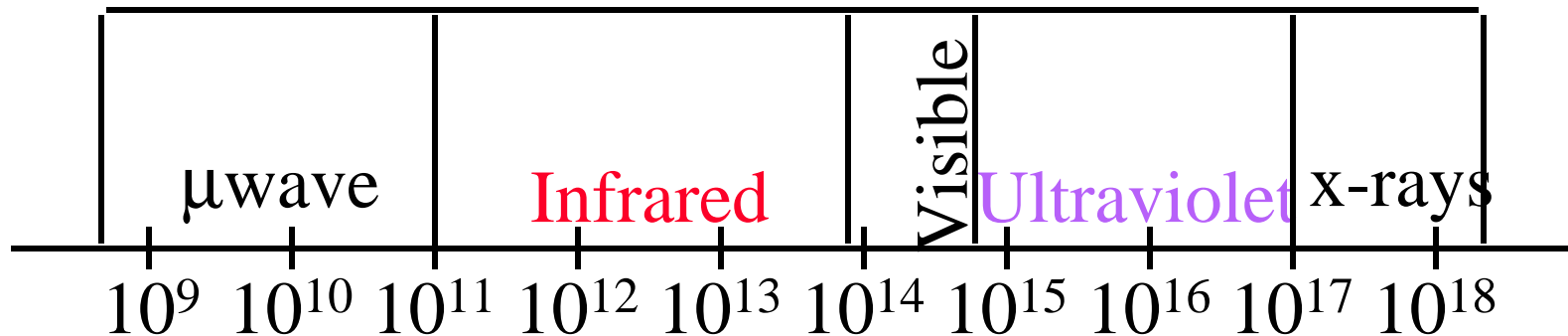

# Wireless LANs

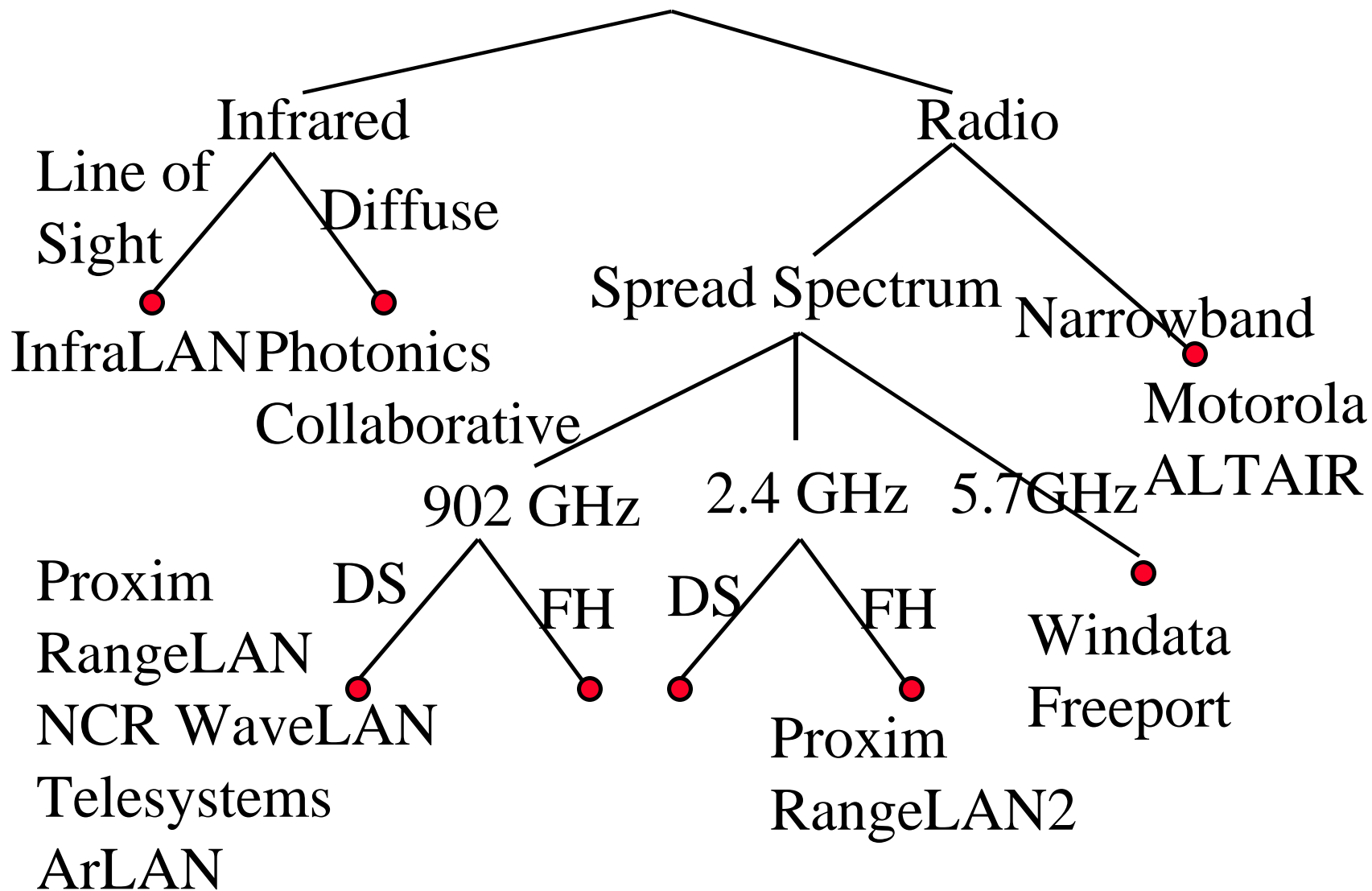

# IEEE 802.11 Features

- ❑ 1 and 2 Mbps
- ❑ Supports both Ad-hoc and base-stations
- ❑ Spread Spectrum  $\Rightarrow$  No licensing required.  
Three Phys: Direct Sequence, Frequency Hopping,  
915-MHz, **2.4 GHz** (Worldwide ISM), 5.2 GHz, and  
Diffused Infrared (850-900 nm) bands.
- ❑ Supports multiple priorities
- ❑ Supports time-critical and data traffic
- ❑ Power management allows a node to doze off

# Hidden Node Problem

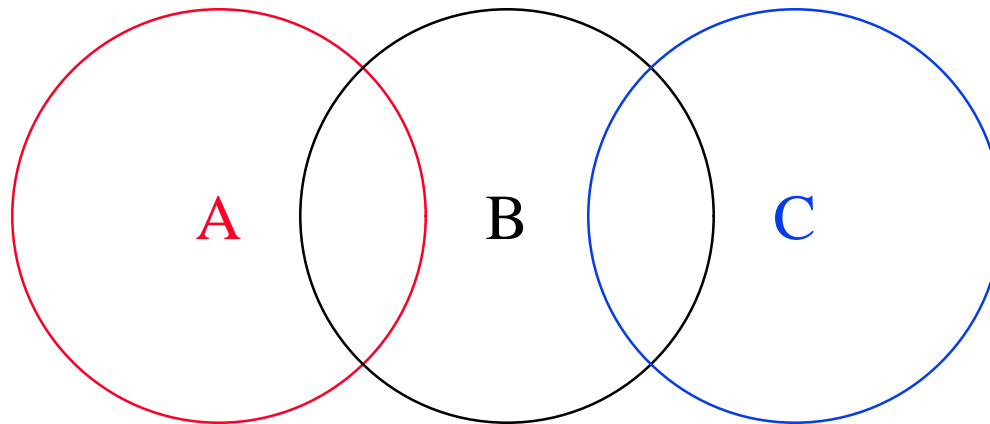

- ❑ C cannot hear A.  
It may start transmitting while A is also transmitting  
 $\Rightarrow$  A and C can't detect collision.
- ❑ Only the receiver can help avoid collisions

# 4-Way Handshake

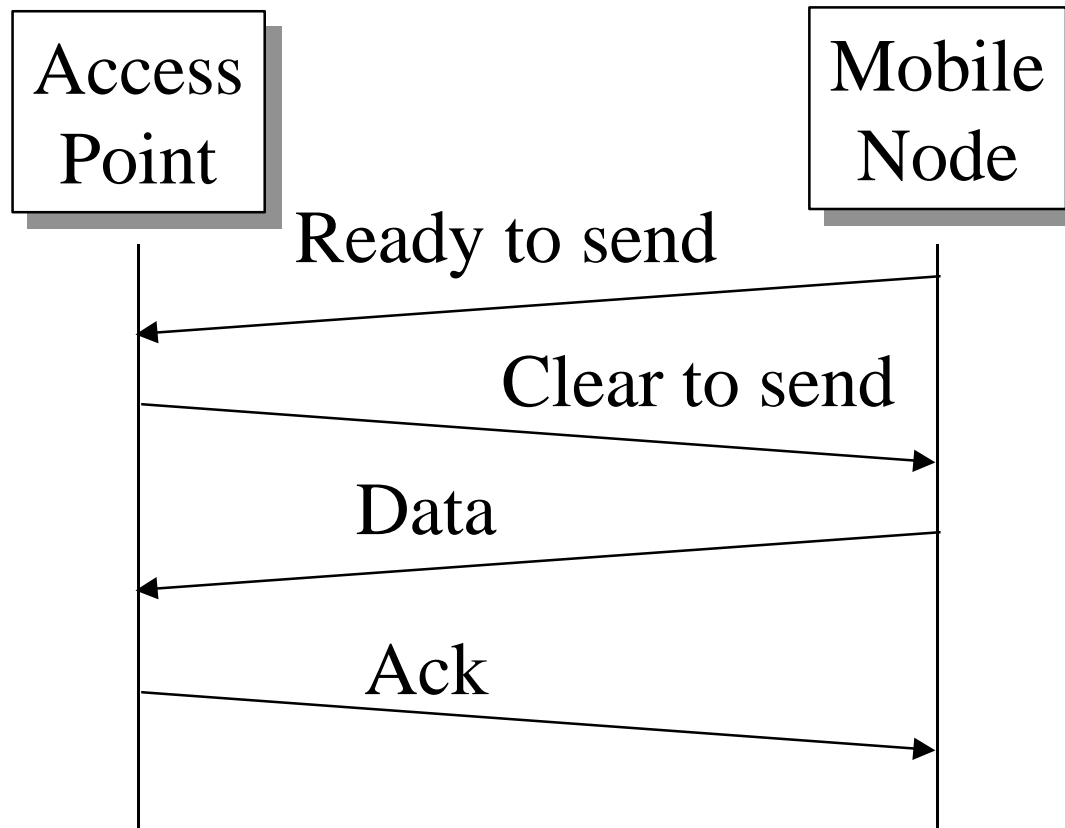

# IEEE 802.11 MAC

- ❑ Carrier Sense Multiple Access with Collision Avoidance (CSMA/CA)
- ❑ Listen before you talk. If the medium is busy, the transmitter backs off for a random period.
- ❑ Avoids collision by sending a short message: Ready to send (RTS)  
RTS contains dest. address and duration of message.  
Tells everyone to backoff for the duration.
- ❑ Destination sends: Clear to send (CTS)
- ❑ Can not detect collision  $\Rightarrow$  Each packet is acked.
- ❑ MAC level retransmission if not acked.

# Peer-to-Peer or Base Stations?

- ❑ Ad-hoc (Autonomous) Group:
  - Two stations can communicate
  - All stations have the same logic
  - No infrastructure, Suitable for small area
- ❑ Infrastructure Based: Access points (base units)
  - Stations can be simpler than bases.
  - Base provide connection for off-network traffic
  - Base provides location tracking, directory, authentication  $\Rightarrow$  Scalable to large networks
- ❑ IEEE 802.11 provides both.

# IEEE 802.11 Architecture

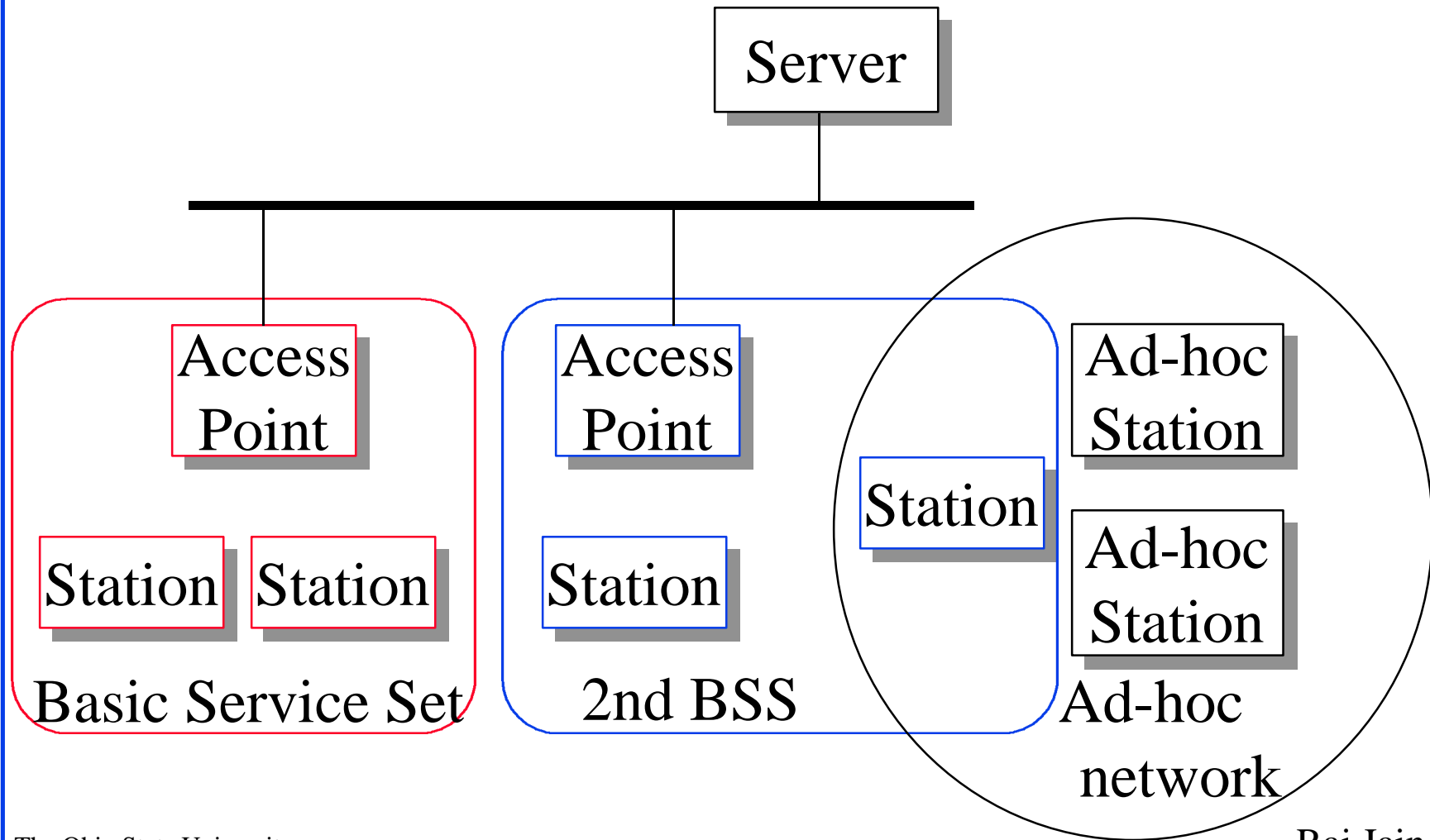

# IEEE 802.11 Priorities

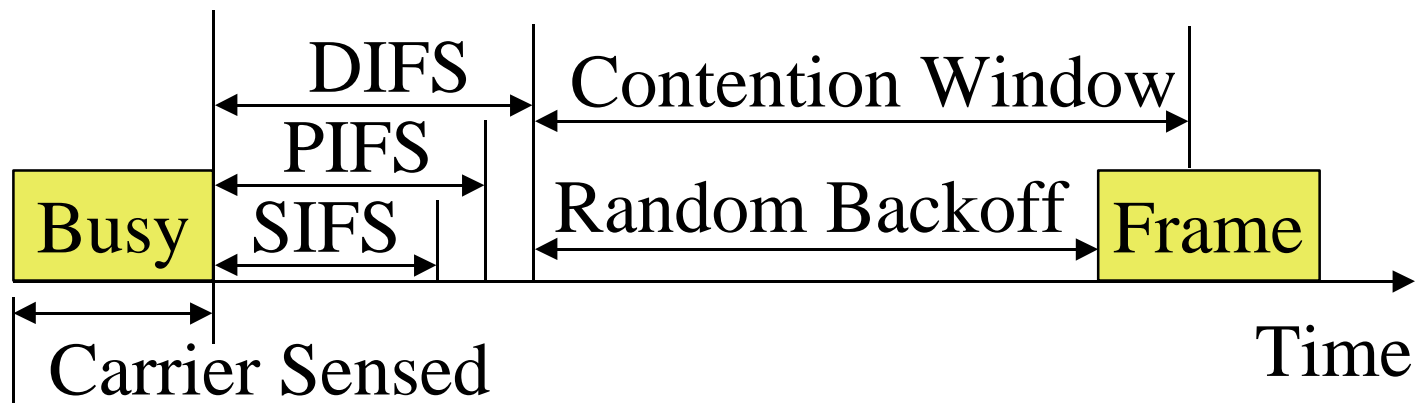

- ❑ Initial interframe space (IFS)
- ❑ Highest priority frames, e.g., Acks, use short IFS (SIFS)
- ❑ Medium priority time-critical frames use “Point Coordination Function IFS” (PIFS)
- ❑ Asynchronous data frames use “Distributed coordination function IFS” (DIFS)

# Time Critical Services

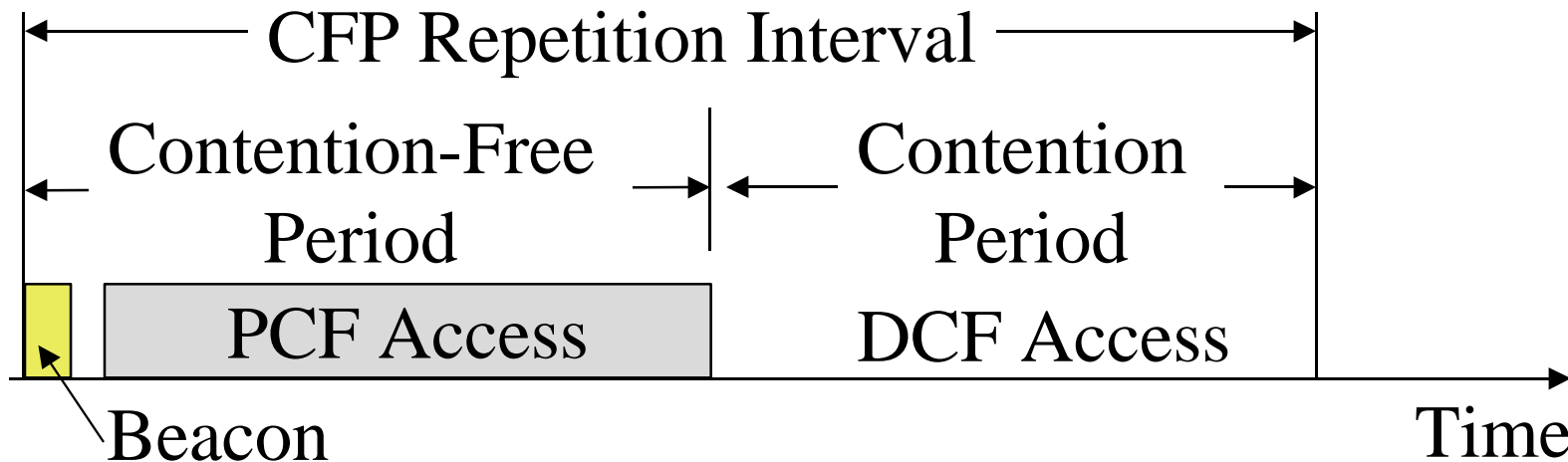

- ❑ Timer critical services use Point Coordination Function
- ❑ The point coordinator allows only one station to access
- ❑ Coordinator sends a beacon frame to all stations.  
Then uses a polling frame to allow a particular station to have contention-free access
- ❑ Contention Free Period (CFP) varies with the load.

# Power Management

- ❑ A station can be in one of three states:
  - Transmitter on
  - Receiver only on
  - Dozing: Both transmitter and receivers off.
- ❑ Access point (AP) buffers traffic for dozing stations.
- ❑ AP announces which stations have frames buffered.  
Traffic indication map included in each beacon.  
All multicasts/broadcasts are buffered.
- ❑ Dozing stations wake up to listen to the beacon.  
If there is data waiting for it, the station sends a poll frame to get the data.

# HIPERLAN

- ❑ High Performance Radio LAN
- ❑ European Telecom Standards Institute (ETSI)'s subtechnical committee RES10.
- ❑ 5.12-5.30 GHz and 17.1-17.3 GHz bands
- ❑ Phy: 23.5 Mbps on 23.5 MHz, non-spread spectrum (GMSK)
- ❑ MAC: CSMA/CA but different from IEEE 802.11
- ❑ Peer-to-peer only.
- ❑ Power management: Nodes announce their wakeup cycle. Other nodes send according to the cycle. A low-bit rate header allows nodes to keep most ckts off.

# Wireless ATM

- ❑ Group officially began August 96
- ❑ Wireless Access Layer (WAL) includes PHY, MAC, and LLC layers.
- ❑ M = Mobility enhanced = Handoff, Location, QoS
- ❑ PNNI', UNI', BICI' support transport of mobility info

AAL
ATM
WAL

User Plane

PNNI + M, UNI + M, B-ICI + M
Signaling AAL
ATM
WAL

PNNI', UNI' B-ICI'
Signaling AAL
ATM
WAL

Control Planes

# Reference Configurations

- ❑ Fixed Wireless
- ❑ End user mobility
- ❑ Network mobility
- ❑ Ad-hoc

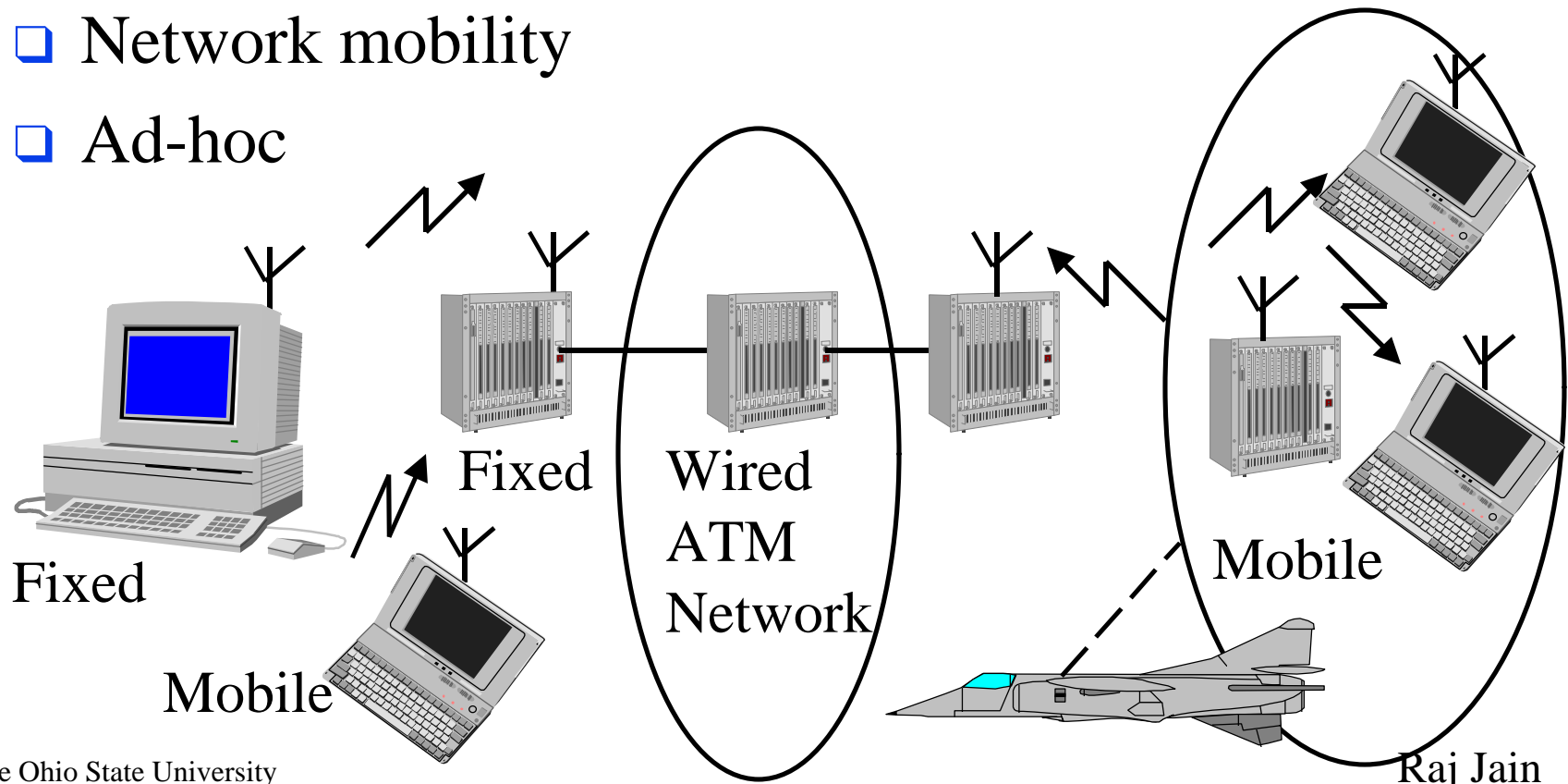

# Mobile IP: Features

- ❑ You can take your notebook to any location
- ❑ Finds nearby IP routers and connects *automatically*. You don't even have to find a phone jack.
- ❑ Only "Mobility Aware" routers and mobile units need new s/w. Other routers and hosts can use current IP
- ❑ No new IP addresses or address formats
- ❑ Secure: Allows authentication
- ❑ Also supports mobile networks (whole airplane/car load of mobile units)

# Mobile IP: Mechanisms

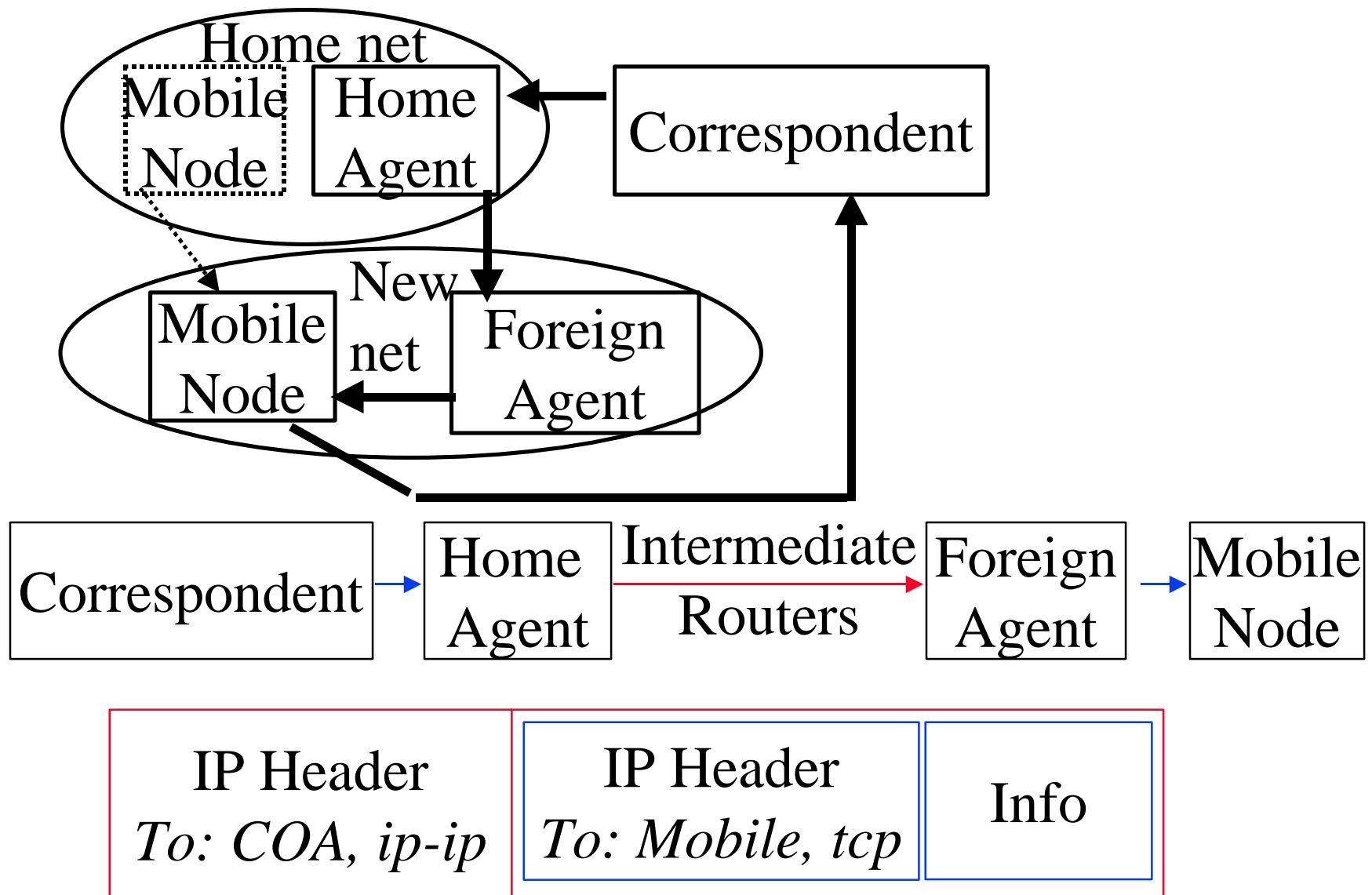

# Mechanism (Cont)

- ❑ Mobile node finds foreign agents via solicitation or advertising
- ❑ Mobile registers with the foreign agents and informs the home agent
- ❑ Home agent intercepts mobile node's datagrams and forwards them to the care-of-address
- ❑ Care-of-address (COA): Address of the end-of-tunnel towards the mobile node. May or may not be foreign agent
- ❑ At COA, datagram is extracted and sent to mobile

# Summary

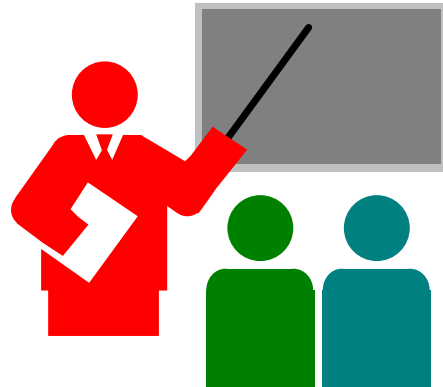

- ❑ Spread spectrum: Frequency hopping or direct sequence
- ❑ WANs: ARDIS, RAM, Cellular, CDPD, Metricom
- ❑ Proprietary LANs: Photonics, RangeLan, ALTAIR
- ❑ LAN Standards: IEEE 802.11, Hiperlan
- ❑ Wireless ATM work is just beginning
- ❑ Mobile IP allows a node to move with same address

# Wireless: Key References

- ❑ For a detailed list of references see:  
[http://www.cis.ohio-state.edu/~jain/refs/wir\\_refs.htm](http://www.cis.ohio-state.edu/~jain/refs/wir_refs.htm)
- ❑ R. A. Dayem, “Mobile Data & Wireless LAN Technologies,” Prentice-Hall, 1997
- ❑ R. LaMaire, et al, "Wireless LANs and Mobile Networking: Standards and Future Directions," IEEE Communications Magazine, August 1996, pp. 86-94,  
<http://www.comsoc.org/pubs/ci/comsoc/>
- ❑ Baseline Text for Wireless ATM specifications, ATM Forum/btd-watm-01.04.txt, September 1997.

# References (Cont)

- RFC 2002, "IP Mobility Support",  
10/22/1996, 79 pp.,  
<http://ds.internic.net/rfc/rfc2002.txt>

# Credits

This MBone transmission was made possible by:

- ❑ Mark Fullmer, OSU/UTS
- ❑ Mike Iverson, OSU/UTS
- ❑ Mike Douglas, OSU/UTS
- ❑ Jayaraman Iyer, OSU/CIS
- ❑ Sohail Munir, OSU/CIS

# Thank You!

