

# Frame Relay

Raj Jain

Professor of Computer and Information Sciences

The Ohio State University

Columbus, OH 43210

Jain@ACM.Org

<http://www.cis.ohio-state.edu/~jain/>



- ❑ What is Frame Relay?
- ❑ Why not leased lines or X.25?
- ❑ Frame formats and protocols
- ❑ Signaling

# Problems with Leased Lines

- ❑ No user-to-user end-to-end signaling
- ❑ Multiple logical links  $\Rightarrow$  Multiple connections
- ❑ Four nodes  $\Rightarrow$  12 ports, 12 local exchange carrier (LEC) access lines, 6 inter-exchange carrier (IXC) connections
- ❑ One more node  $\Rightarrow$  8 more ports, 8 more LEC lines, 4 more IXC circuits

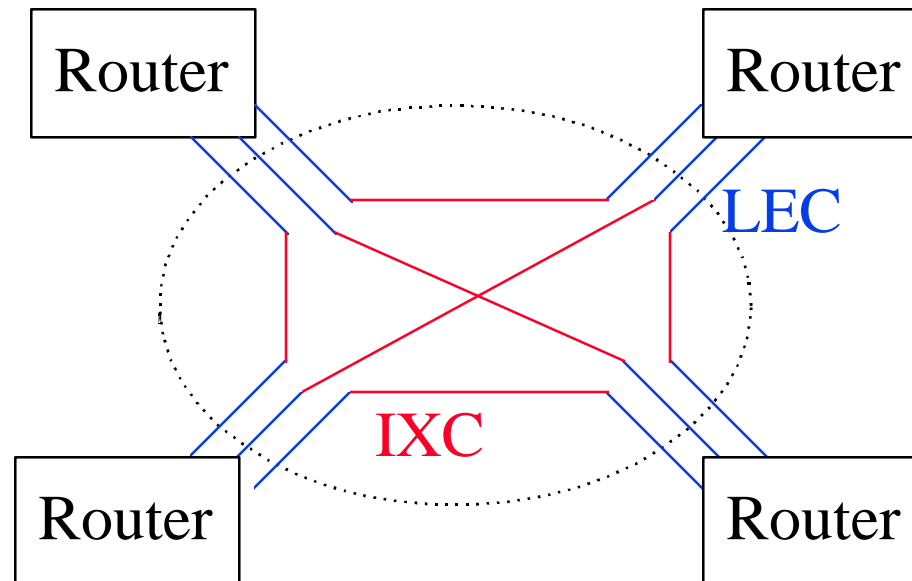

# Solution: Frame Relay

- ❑ Four nodes: 4 ports, 4 LEC access lines, 6 IXC circuits
- ❑ One more node: 1 more port, 1 more access line, 4 more IXC circuits
- ❑ Share leased lines  $\Rightarrow$  Virtual Private Networks

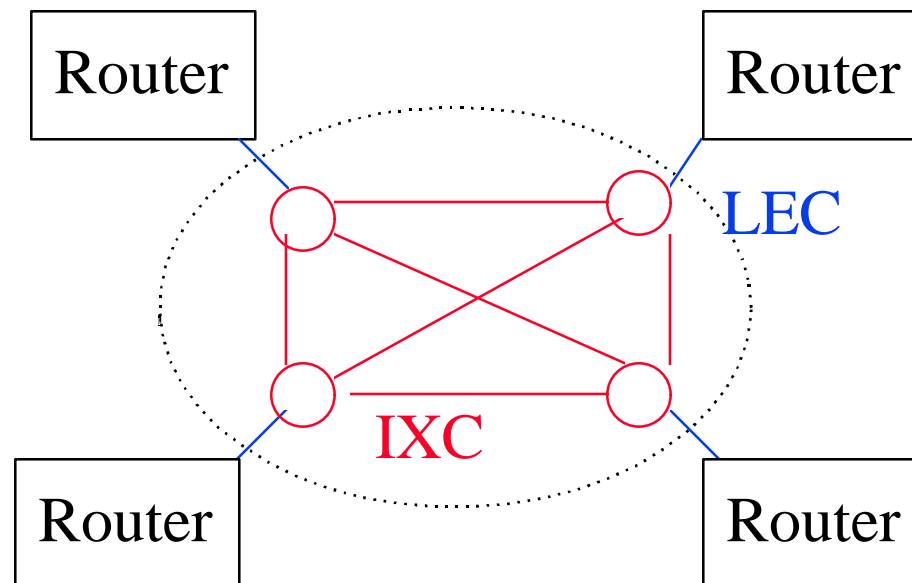

# Data Link Control Identifiers (DLCI)

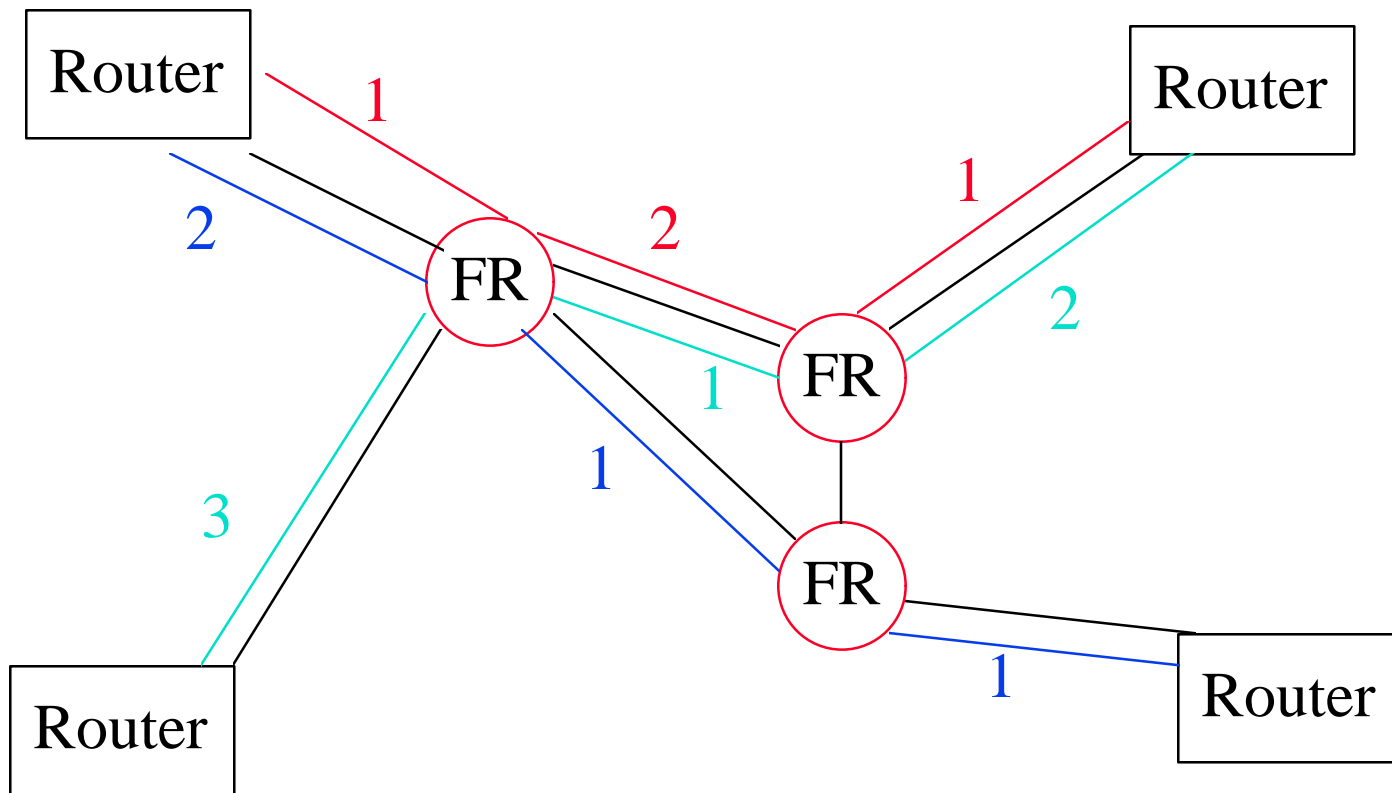

# Data Link Control Identifier

- ❑ Only local significance
- ❑ Allows multiple logical connections over one circuit
- ❑ Some ranges preassigned
- ❑ DLCI = 0 is used for signaling

# X.25

- ❑ In-band signaling. VC setup and clearing messages in the same channel as data.
  - ❑ Three layer protocol. Third layer for multiplexing.
  - ❑ Flow control
  - ❑ Error control
- ⇒ 12 messages for one packet transfer
- Only 6 messages without flow control and error control

# X.25 Exchange

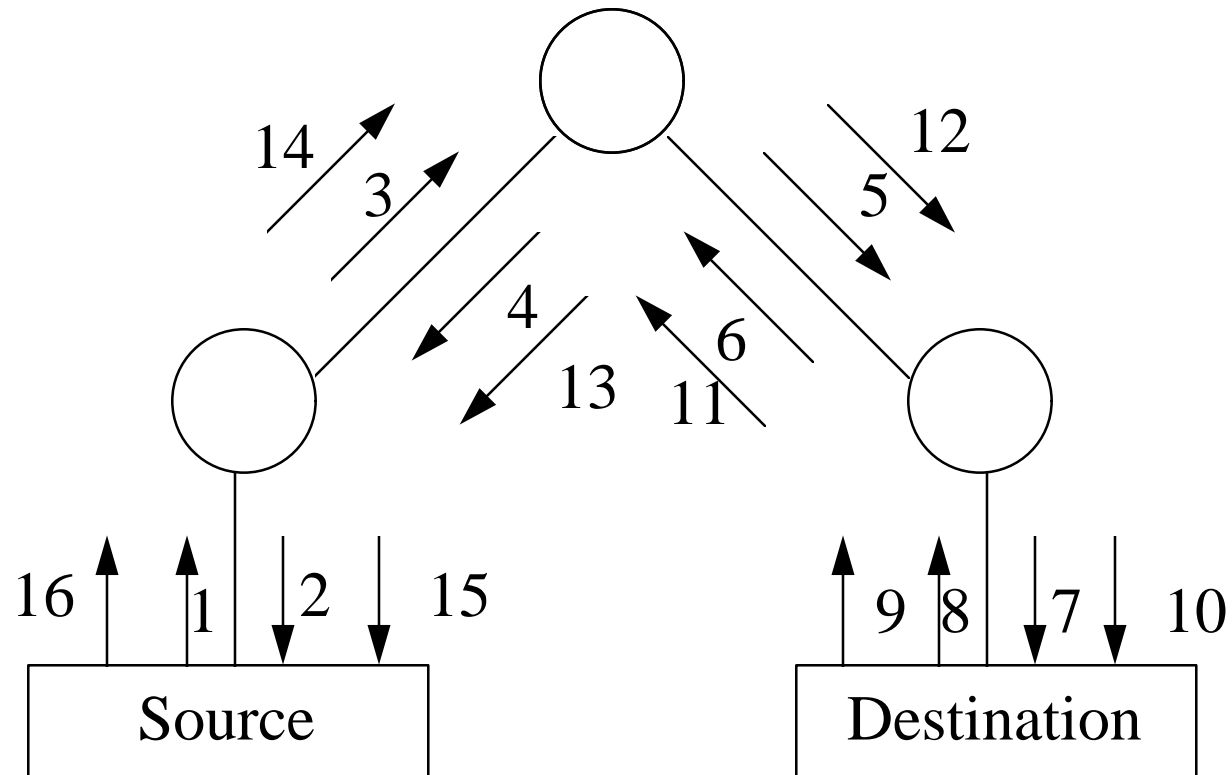

# Frame Relay Exchange

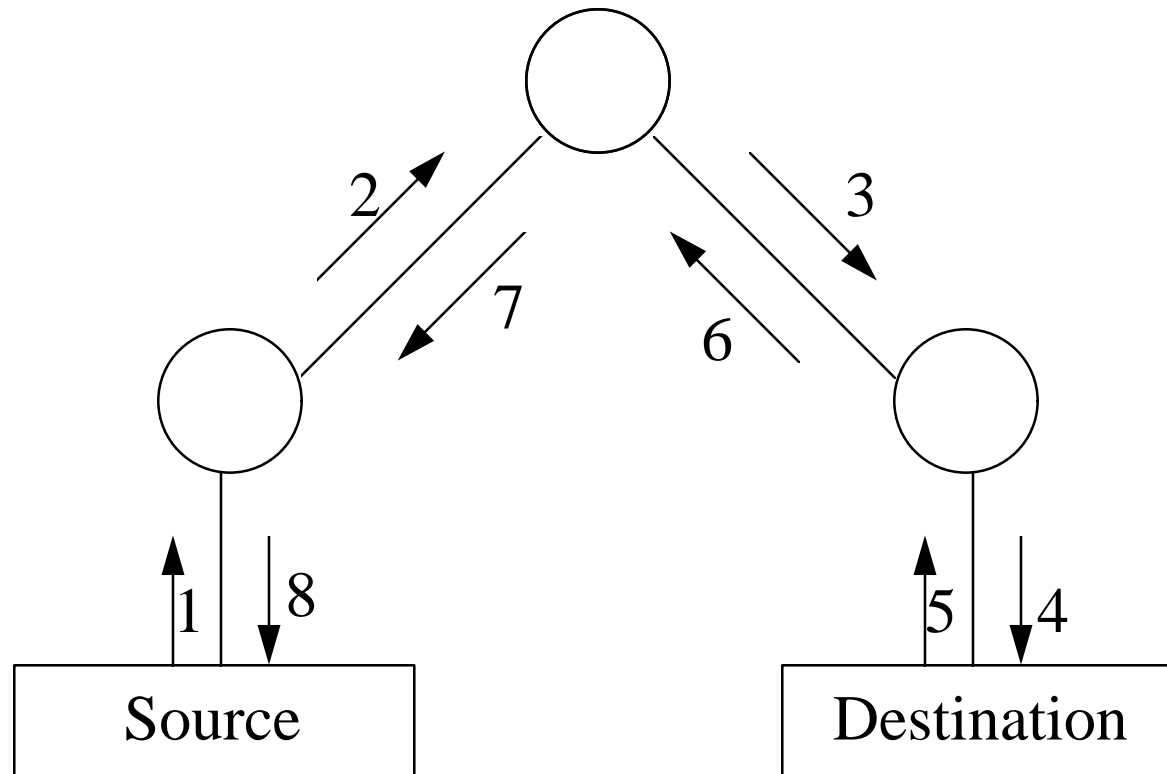

# Frame Relay: Key Features

- ❑ X.25 simplified
  - ❑ No flow and error control
  - ❑ Out-of-band signaling
  - ❑ Two layers
  - ❑ Protocol multiplexing in the second layer
  - ❑ Congestion control added
- ⇒ Higher speed possible.  
X.25 suitable to 200 kbps. Frame relay to 2.048 Mbps.

# Relay vs Switching

- ❑ Switching = Relaying + Ack + Flow control + Error recovery + loss recovery
- ❑ Switching = X.25
- ❑ Relay = Unreliable multiplexing service

# Frame Relay UNI Architecture

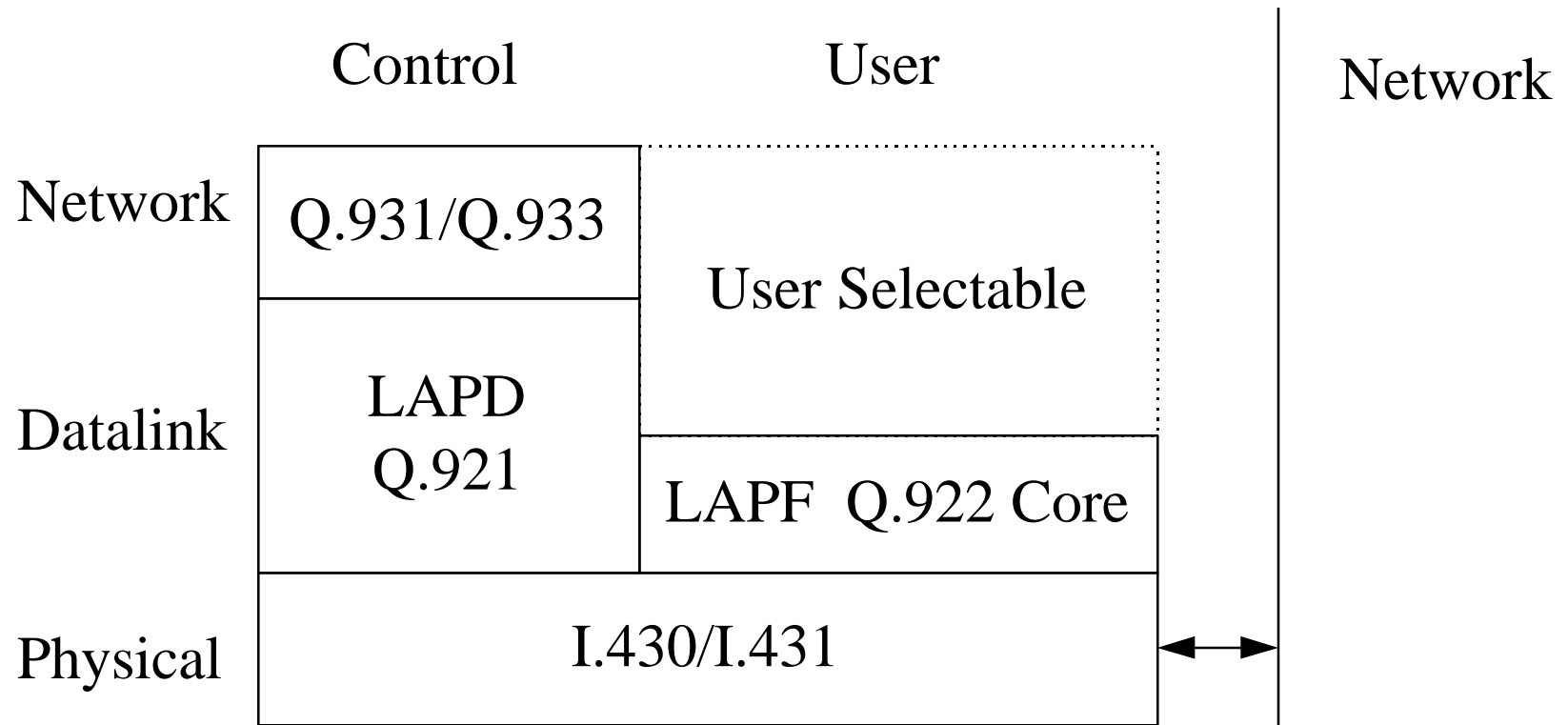

# Control Plane

- ❑ Signaling over D channel
- ❑ Data transfer over B, D, or H
- ❑ LAPD used for reliable signaling
- ❑ Q.933 + Q.931 used for signaling messages
- ❑ SAPI = 0 in LAPD  $\Rightarrow$  Q.933 + Q.931 Frame relay message

# User Plane

- ❑ Link Access Procedure for Frame-Mode bearer services (LAPF)
- ❑ Q.922 = Enhanced LAPD (Q.921) = LAPD + Congestion
- ❑ LAPF defined in Q.922
- ❑ Core functions defined in Q.922 appendix:
  - ❑ Frame delimiting, alignment, and flag transparency
  - ❑ Virtual circuit multiplexing and demultiplexing
  - ❑ Octet alignment  $\Rightarrow$  Integer number of octets before zero-bit insertion
  - ❑ Checking minimum and maximum frame sizes
  - ❑ Error detection, Sequence and non-duplication
  - ❑ Congestion control

- LAPF control functions may be used for end-to-end signaling

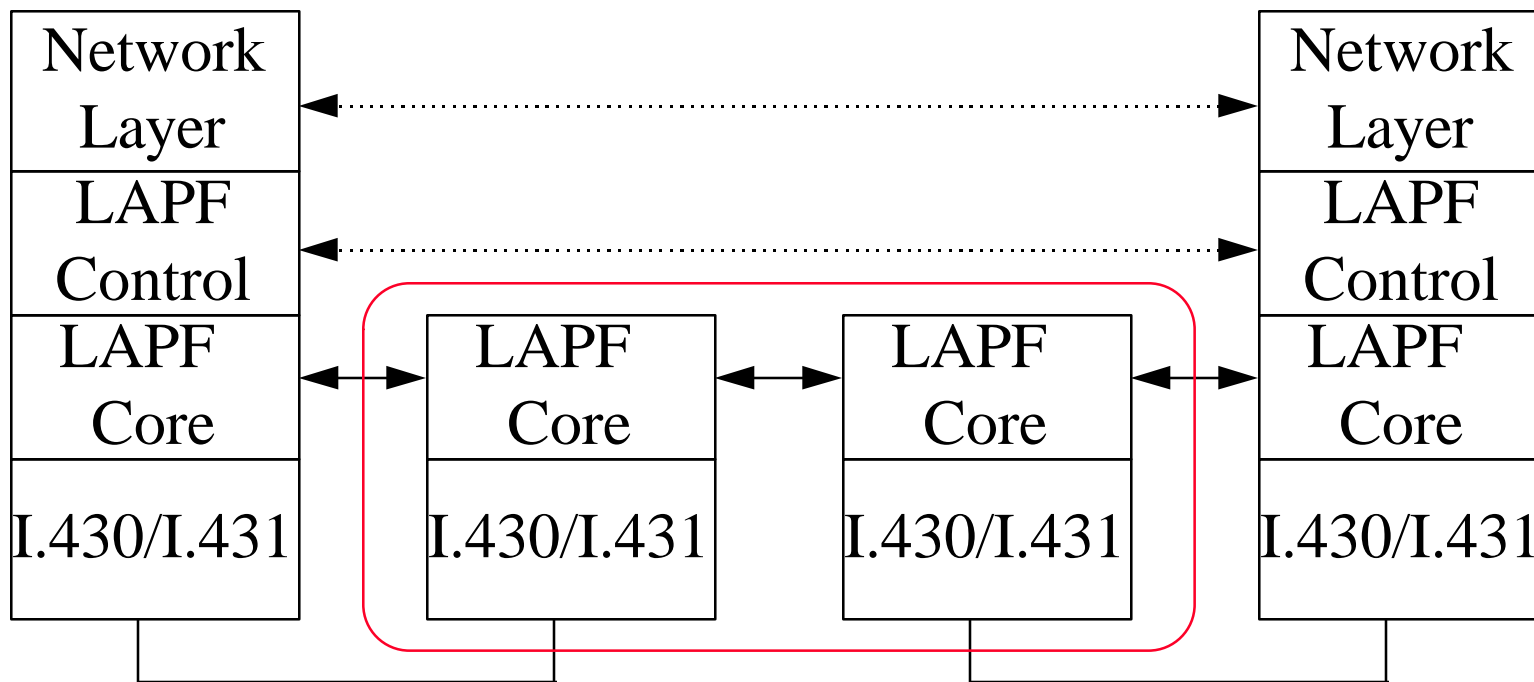

# Signaling

- ❑ Permanent Virtual Circuit (PVC)
- ❑ Switched Virtual Circuit (SVC)
- ❑ Q.933 used for logical FR connections over PVC or SVC  
⇒ Q.933 is a subset of Q.931
- ❑ Message Types: Alerting, call proceeding, connect, connect ack, progress, setup, disconnect, release, release complete, status, status inquiry
- ❑ Frame relay forum has proposed to simplify Q.933 by deleting progress, connect ack, and alerting.  
Also delete many information element.  
Add SVC.

# Digital Signaling System 1 Message Format

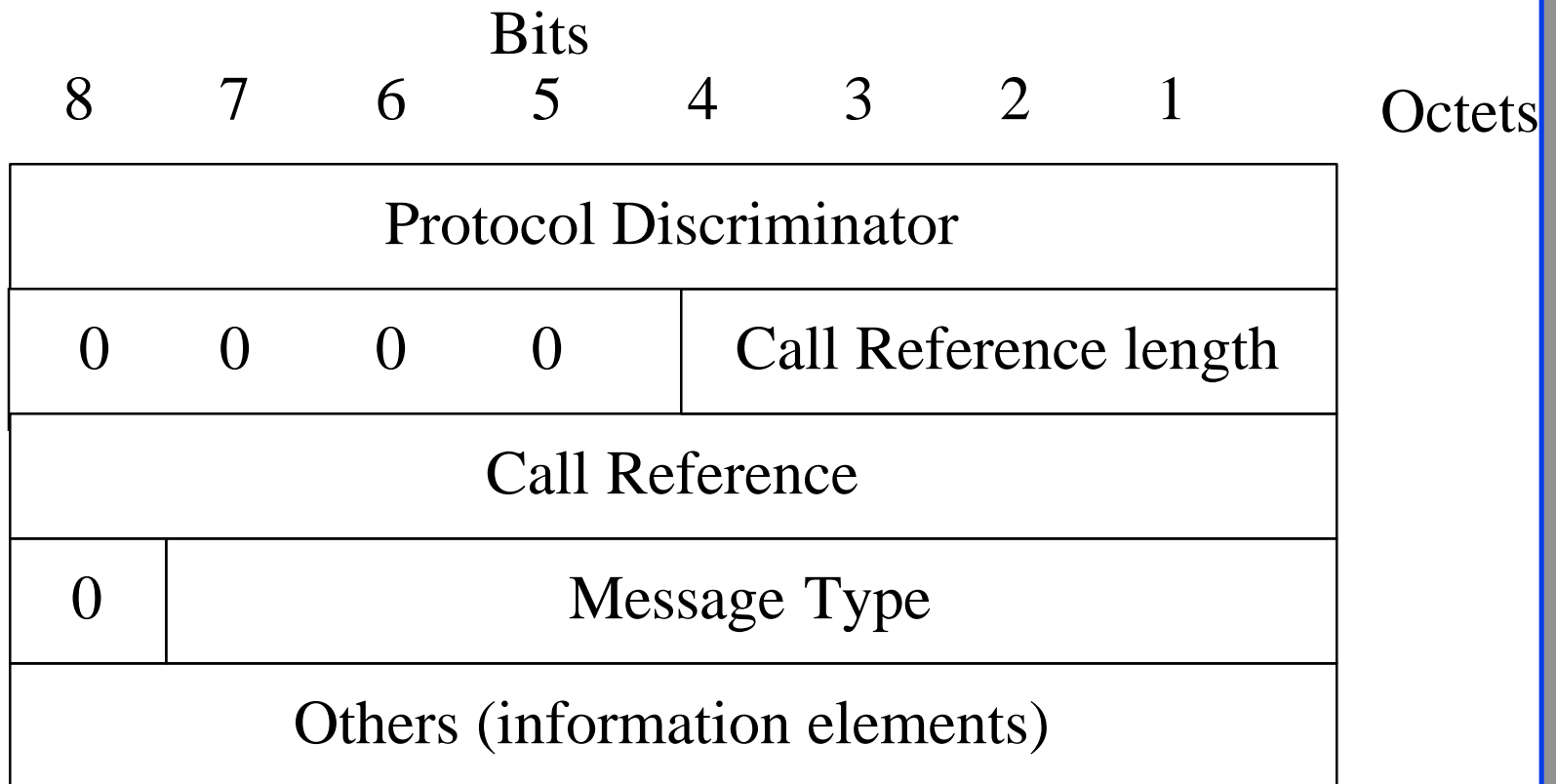

# Connection Control Messages

- **Call establishment**
  1. Alerting
  2. Call proceeding
  3. Connect
  4. Connect Acknowledge
  5. Progress
  6. Setup
- **Call clearing**
  7. Disconnect
  8. Release
  9. Release Complete
- **Miscellaneous**
  10. Status
  11. Status Enquiry

# Information Elements

Information Element	1	2	3	4	5	6	7	8	9	10	11
Protocol discriminator	X	X	X	X	X	X	X	X	X	X	X
Call reference	X	X	X	X	X	X	X	X	X	X	X
Message type	X	X	X	X	X	X	X	X	X	X	X
Cause					X	X	X	X		X	
Bearer capability									X		
Channel identification	X	X	X						X		
Data link connection ID	X	X	X						X		
Progress indicator	X	X	X			X			X		
Network specific facilities									X		
Call state										X	
Display	X	X	X	X	X	X	X	X	X	X	X
End to end transit delay			X						X		

# Information Elements (cont)

Information Element	1	2	3	4	5	6	7	8	9	10	11
Packet binary parameters			X						X		
Link core parameters			X						X		
Link protocol parameters			X						X		
Calling party number									X		
Called party number									X		
Called party subaddress									X		
Connected number			X		X		X	X			
Connected subaddress			X		X		X	X			
Transit network selection									X		
Repeat indicator									X		
Low layer compatibility			X						X		
High layer compatibility									X		
User-User	X		X		X		X	X	X		

# Signaling Example

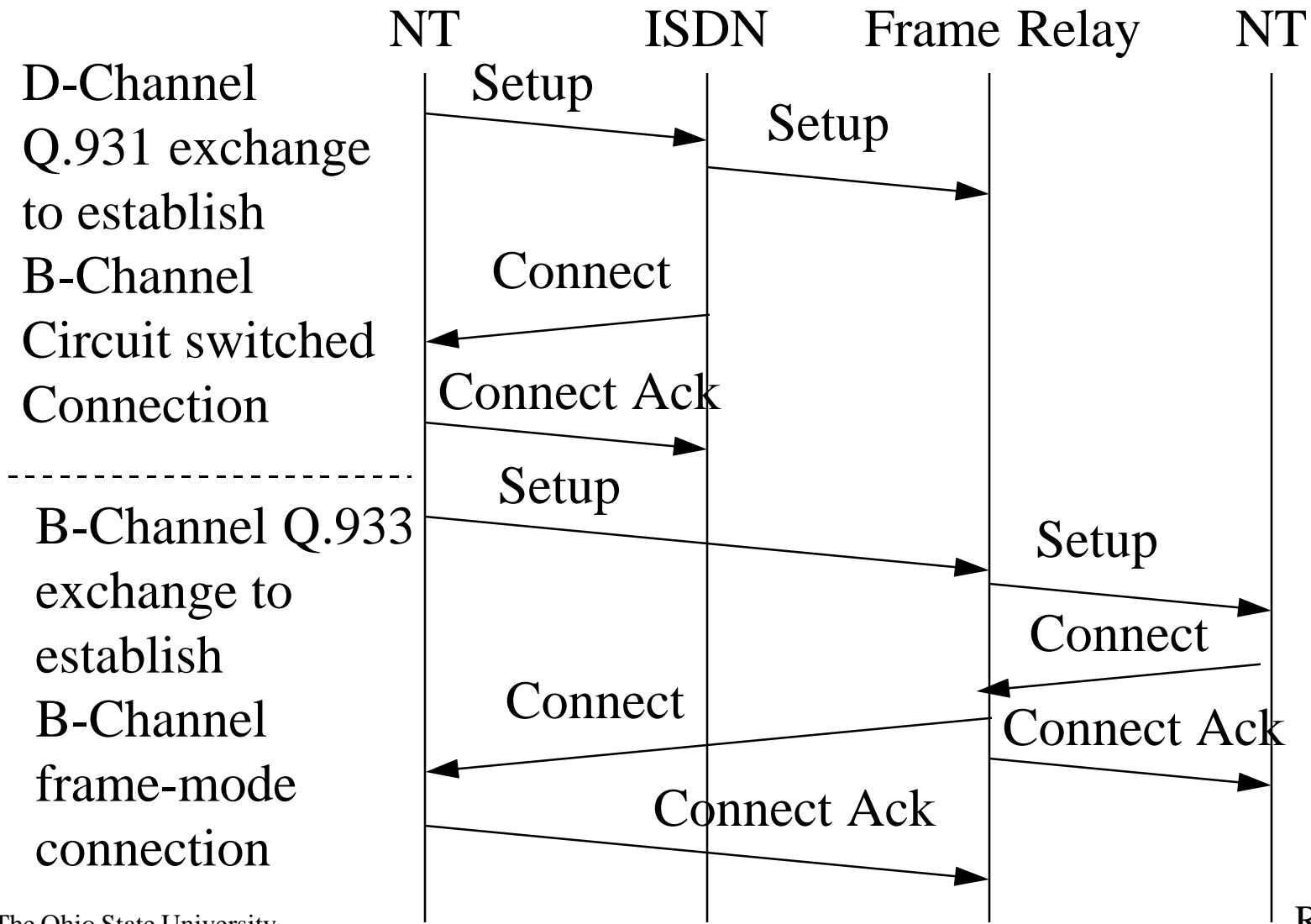

# Signaling Example (cont)

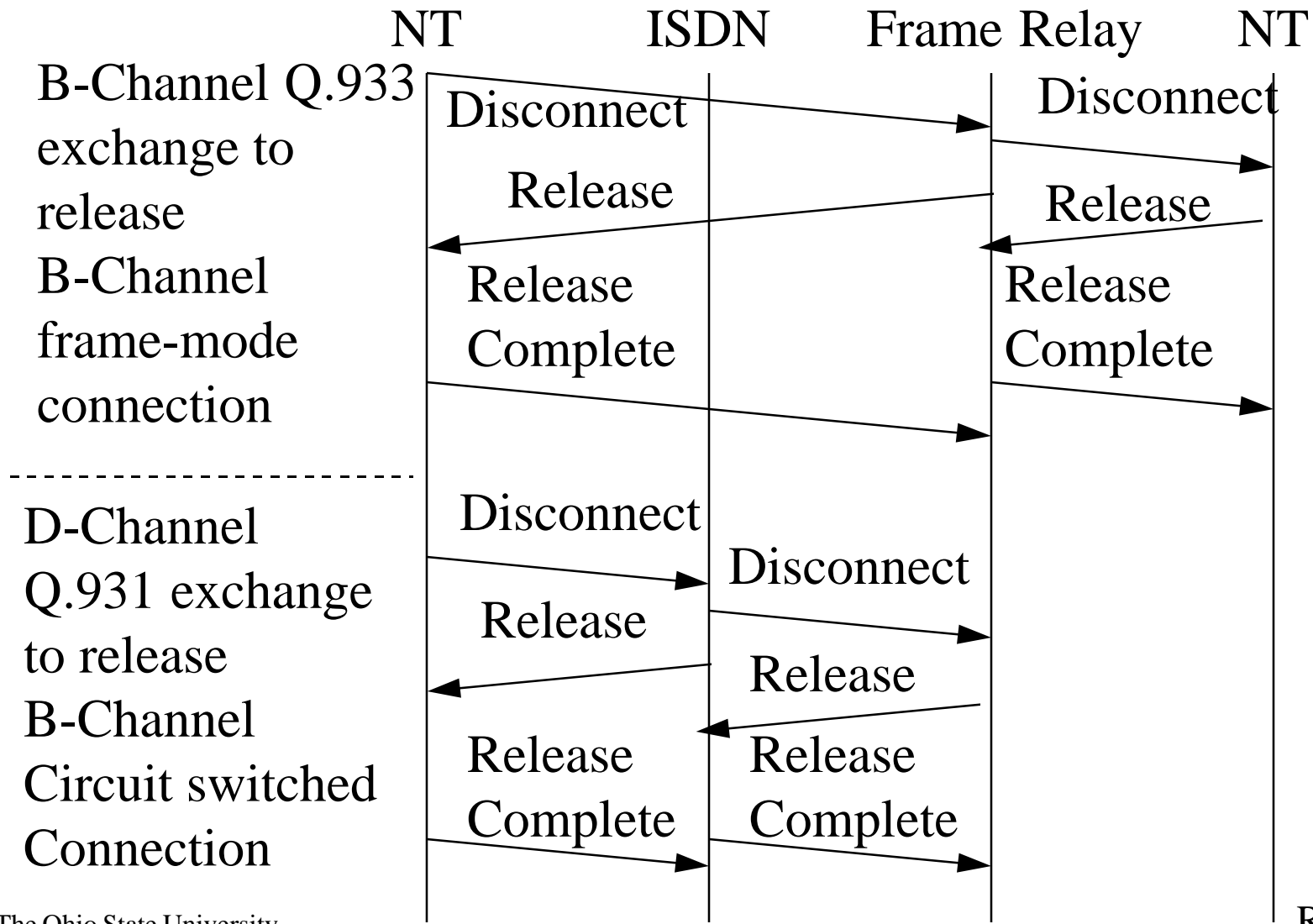

# Local Management Interface (LMI)

- ❑ Extension designed by a group of vendors
- ❑ To overcome problems observed in early implementations
- ❑ May be standardized by both ANSI and ITU-T
- ❑ Status Enquiry message from user to network
- ❑ Status message from network to user
- ❑ Uses HDLC UI frames (with sequence numbers)
- ❑ Uses protocol ID=00001001, DLCI=1023

# LMI Operation

User

Network

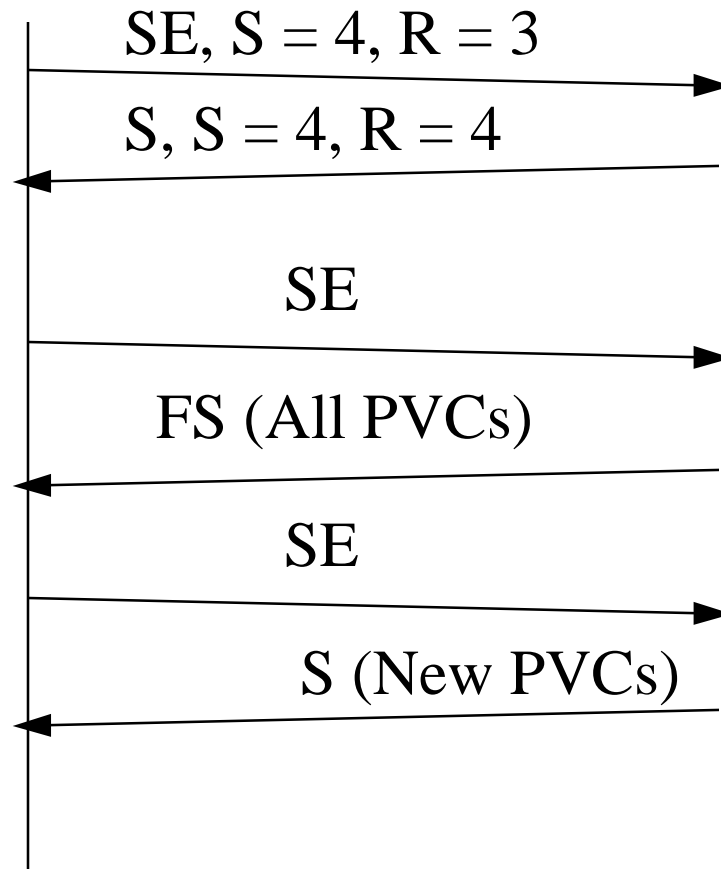

# DLCI Extensions

- ❑ Global DLCI  
⇒ DLCI points to the same destination at all time and points  
(OK for small networks)
- ❑ Multicasting
  - ❑ One-way multicasting: 1 to N
  - ❑ Two-way multicasting: 1 to N and N to 1
  - ❑ N-way Multicasting: N to N

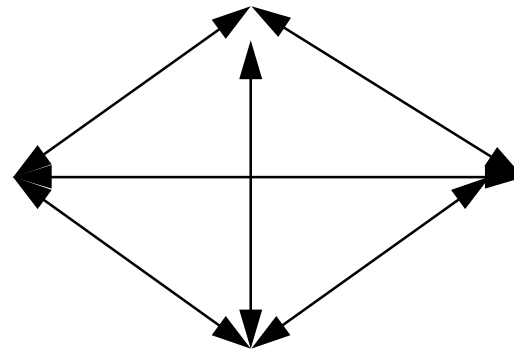
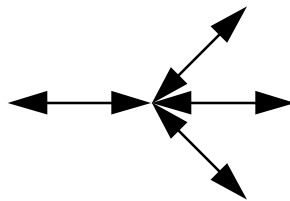
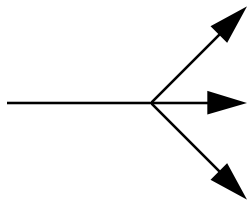

# Network-to-Network Interface (NNI)

- ❑ Developed by frame relay forum: FRF 92.08R1, FRF 92.62
- ❑ Working draft of ANSI T1S1.2
- ❑ Adding/deleting PVCs between networks
- ❑ Diagnosing PVC failures

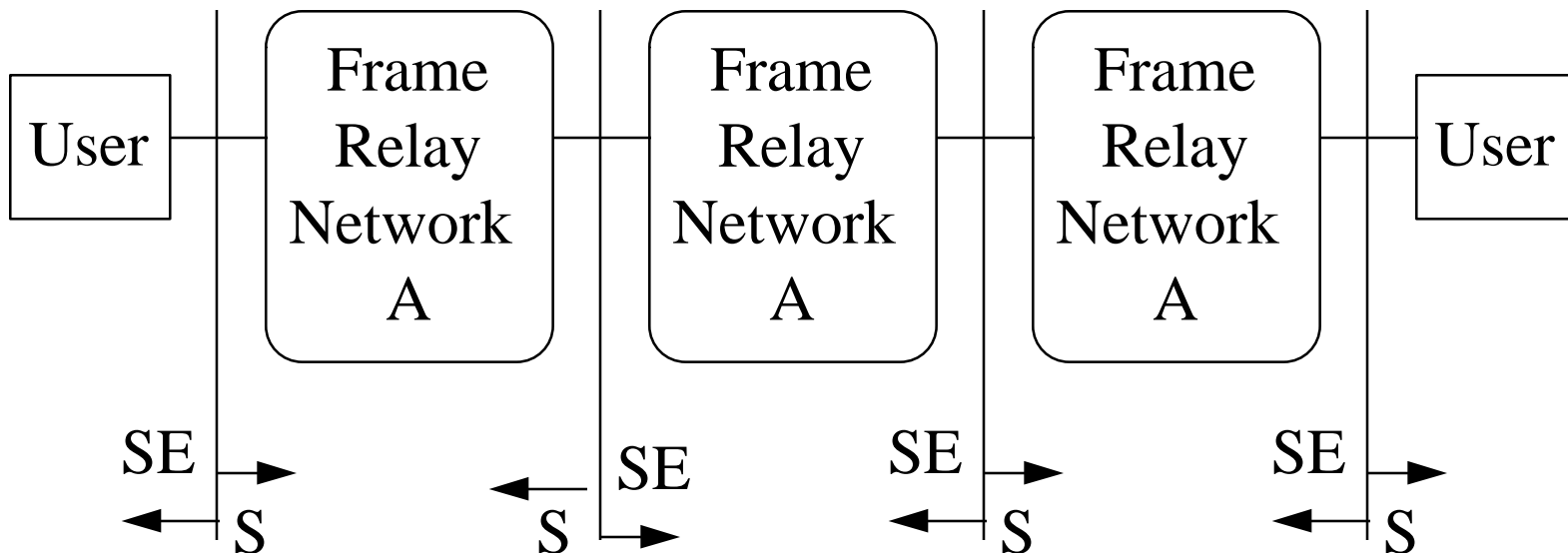

# Major NNI Operations

- ❑ Notification of adding a PVC
- ❑ Notification of deleting a PVC
- ❑ Notification of UNI or NNI failures
- ❑ Notification of a PVC segment availability or unavailability
- ❑ Verification of links between frame relay nodes
- ❑ Verification of frame relay nodes

# Physical Layer Options

- ❑ Both ANSI and ITU-T define frame relay on ISDN
- ❑ Frame relay forum's implementation agreements:
  - ❑ Metallic interface at DS1 1.544 Mbps (ANSI T1.403)
  - ❑ Leased lines at 56 kbps (V.35)
  - ❑ Metallic interface at E1 2.048 Mbps (G.703)
  - ❑ Synchronous interface at E1 2.048 Mbps (G.704)
  - ❑ X.21 interface for synchronous transmission
- ❑ MCI offers frame relay at 56 kbps, 64 kbps, fractional T1,  $N \times 56$  or  $N \times 64$  kbps.

# Summary

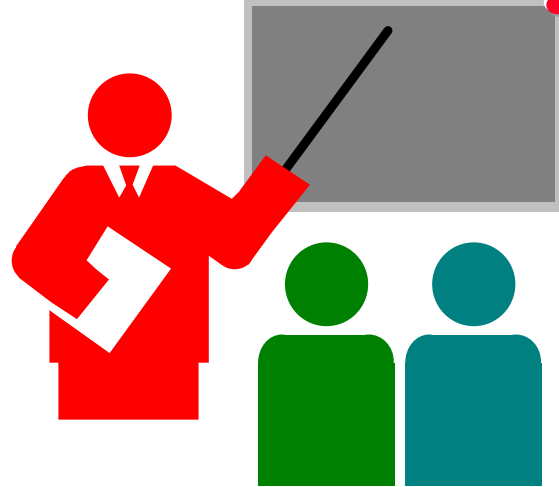

- ❑ X.25 designed for unintelligent devices over error-prone networks  $\Rightarrow$  Slow
- ❑ Frame relay = simplified X.25
- ❑ Higher data rates than X.25
- ❑ Developed for ISDN but runs in non-ISDN environments
- ❑ Two layer protocol architecture

# Homework

- Read Chapter 11 of Stallings' ISDN book

# Frame Relay ITU standards

- ❑ I.122, Framework for Frame Mode Bearer Services, 1993.
- ❑ I.223, Frame Mode Bearer Services, 1992.
- ❑ I.370, Congestion management for the ISDN Frame Relaying Bearer Service, 1991.
- ❑ I.372, Frame Relay Bearer Service Network-to-network Interface Requirements, 1993.
- ❑ I.555, Frame Mode Bearer Services Interworking, 1992.
- ❑ Q.922, ISDN Data Link Layer Specification for Frame Mode Bearer Services, 1992.
- ❑ Q.933, Signaling Specifications for Frame Mode Call Control, 1992.

# Frame Relay ANSI standards

- ❑ T1.606, Architectural Framework and Service Description for Frame-Relaying Bearer Service, 1990.
- ❑ T1.617, Signaling Specification for Frame Relay Bearer Service for DSS1, 1991.
- ❑ T1.618, Core Aspects of Frame Protocol for Use with Frame Relay Bearer Service, 1991.

# Implementation Agreements

- ❑ FRF.1, The User-Network Interface (UNI)
- ❑ FRF.2, The network-to-network interface (NNI)
- ❑ FRF.3, Multiprotocol encapsulation
- ❑ FRF.4, Switched virtual circuit (SVC)
- ❑ FRF.5, Frame relay/ATM network interworking
- ❑ FRF.6, Frame relay service customer network management

Available from Frame Relay Forum,  
<http://frame-relay.indiana.edu/>