

Fundamentals of Telecommunications

Raj Jain

Professor of CIS

The Ohio State University

Columbus, OH 43210

Jain@ACM.Org

<http://www.cis.ohio-state.edu/~jain/>



- ❑ Time Division Multiplexing T1, T3, DS1, E1
- ❑ T1 Framing
- ❑ Echo Cancellation
- ❑ Signaling

Time Division Multiplexing

- ❑ Voice signal has a bandwidth of 4 kHz
- ❑ Nyquist sampling theorem:
Sample at twice the highest signal frequency
⇒ Sample at 8 kHz ⇒ Sample every 125 μsec
- ❑ 256 levels ⇒ 8 bits per sample × 8000 samples/sec = 64 kbps
- ❑ In 1962, telephone carrier (cable) between Bell System offices could carry approximately 1.5 Mbps over a mile = Distance between manholes in large cities = Distance between amplifiers
- ❑ $1500/64 \approx 24$ ⇒ Can multiplex approximately 24 voice channels on that carrier ⇒ Telecommunication-1 carrier or T1 carrier. Named after the ANSI committee.

T1 Frame

- ❑ T1= 24 voice channels = Digital Service 1 = DS1
- ❑ Used time-division multiplexing:

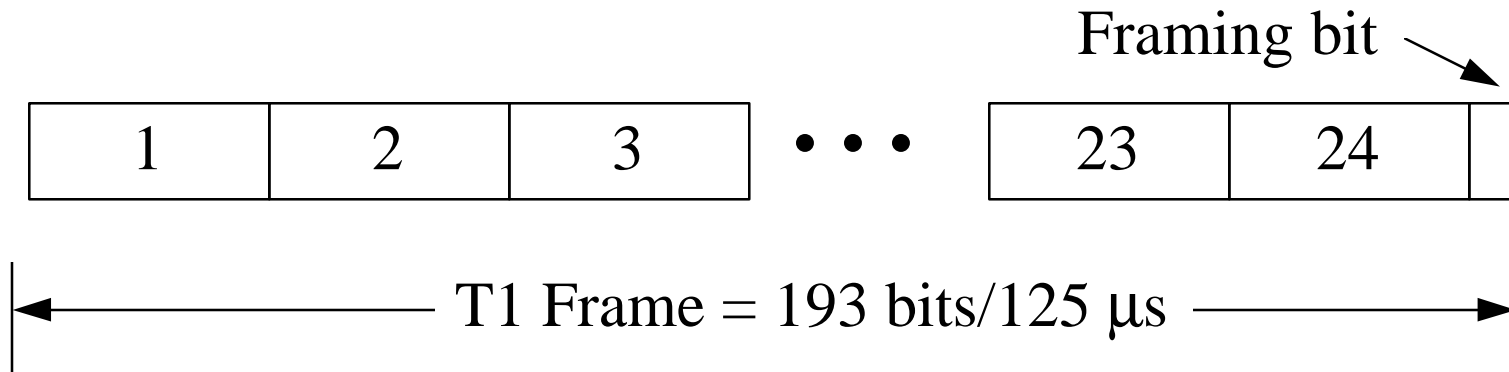

- ❑ Framing: Add 101010 (1 bit per frame)



- ❑ Any other sequence \Rightarrow Resynchronize

T1 Signaling

- ❑ Initially, 8th bit of every channel was used for signaling
- ❑ Now, every 6th frame, the 8th bit of each channel is used for signaling
- ❑ Net rate = $(8 \times 5+7)/(125 \times 6) = 62.66$ kbps
- ❑ For digital data service, 24th channel is used for sync byte which allows faster and more reliable frame resynchronization. 8th bit in each of the 23 channels indicates whether the data is user's or system control
- ❑ 8th bit is not reliable
⇒ Use only 7 bits per frame ⇒ 56 kbps
- ❑ For mixture of voice and data, all 24 channels can be used.
No sync bytes.

Subrate Multiplexing

- ❑ Used for data rates lower than 56 kbps.
- ❑ One bit of the 7 bits is used to indicate data rate
- ❑ 6 bits per channel = 48 kbps
 - ❑ Five 9.6 kbps subchannels
 - ❑ Ten 4.8 kbps subchannels
 - ❑ Twenty 2.4 kbps subchannels
- ❑ Five subchannels \Rightarrow Subchannel 1 uses frames 1, 6, 11, ...

Digital TDM Hierarchy

North America		European		Japan	
DS0	64 kbps		64 kbps		64 kbps
DS1	1.544 Mbps	E1	2.048 Mbps		1.544 Mbps
DS2	6.313 Mbps	E2	8.448 Mbps		6.312 Mbps
DS3	44.736 Mbps	E3	34.368 Mbps		32.064 Mbps
DS4	274.176 Mbps	E4	139.264 Mbps		97.728 Mbps
DS1C	3.152 Mbps	E5	565.148 Mbps		397.200 Mbps

300 bps over Single Pair

- 300 bps modems (Bell 108 specification)
- Use frequency shift keying
 - 0 \Rightarrow 1070 Hz, 1 \Rightarrow 1270 Hz in one direction
 - 0 \Rightarrow 2025 Hz, 1 \Rightarrow 2225 Hz in the other direction

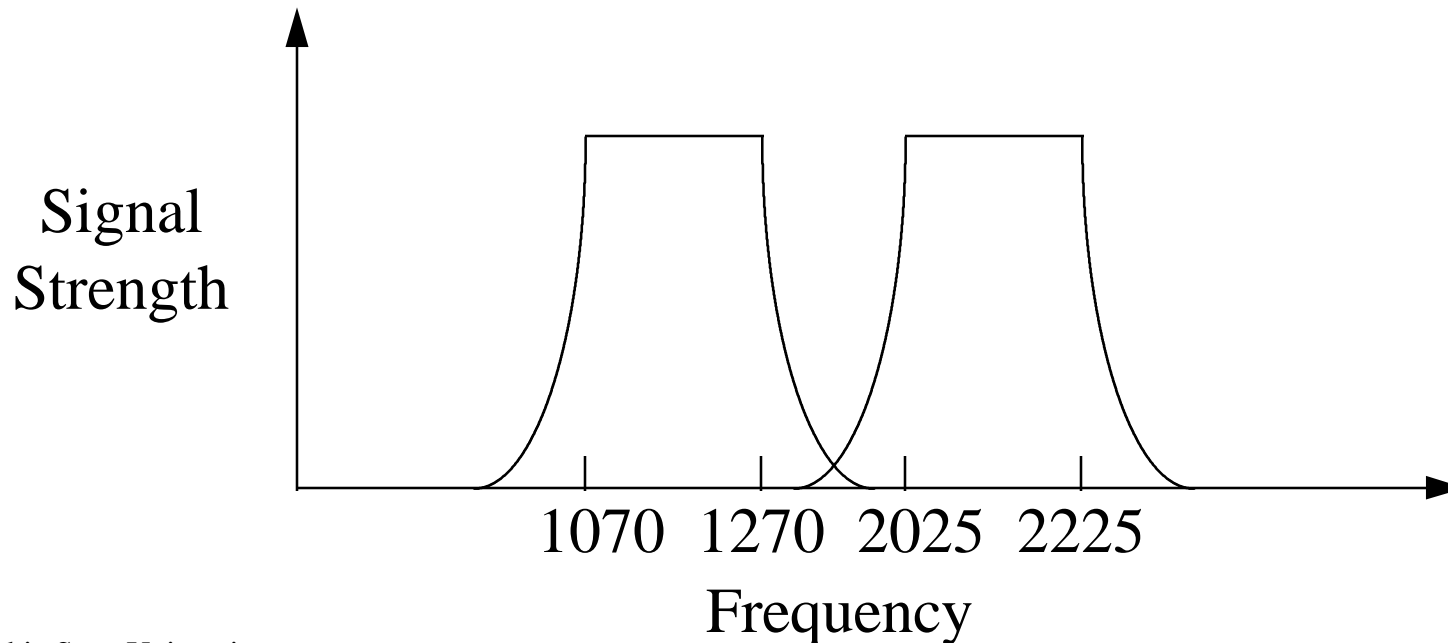

Echo Cancellation

- ❑ Problem: Full duplex transmission over a single pair
- ❑ Solution 1: Use different frequencies for the two directions. Only half of the bandwidth available for each direction
- ❑ Solution 2: Use digital signal \Rightarrow Some part of the signal returns (echo). Near-end and far-end echoes

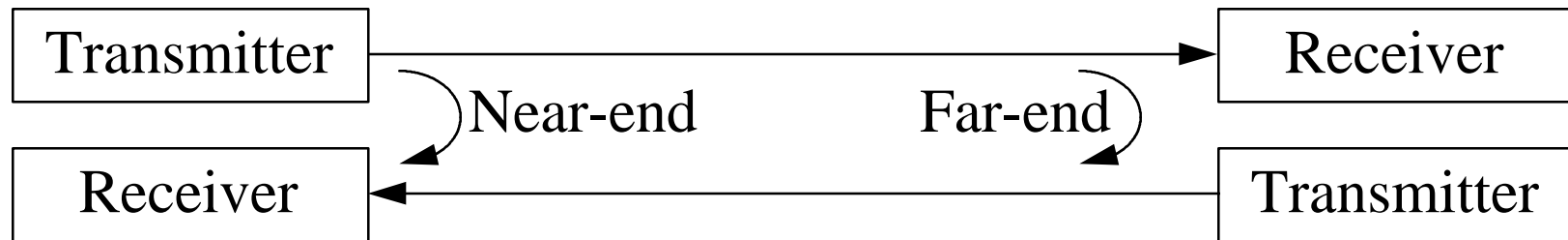

- ❑ Echo Cancellation: Estimate echo and subtract from received signal. Transmitted signal is known. Reflections from various distances along the path are estimated and subtracted from the received signal \Rightarrow 144 kbps up to 4 km

Time-Compression Multiplexing

- ❑ Half-duplex transmission
- ❑ Central office and subscriber take turns for transmitting
- ❑ Some time is allowed for propagation delay and for the line to turn around
- ❑ Wire rate is more than twice the signal rate

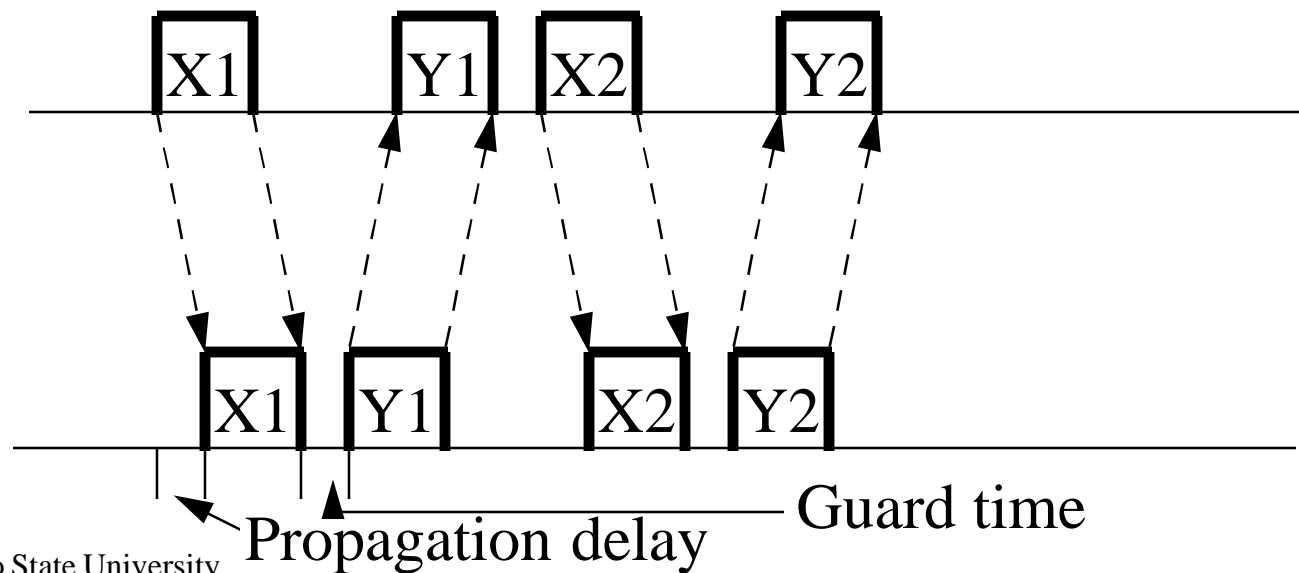

Optical Fiber in the Local Loop

- ❑ Distribution network uses a star topology
- ❑ Feeder cables connect central office to remote nodes
- ❑ Initially, feeder cables can be replaced via fiber. May multiplex using TDM or WDM
- ❑ Active star Remote node \Rightarrow It multiplexes/demultiplexes.
- ❑ Passive star remote node \Rightarrow Subscriber equipment multiplexes/demultiplexes

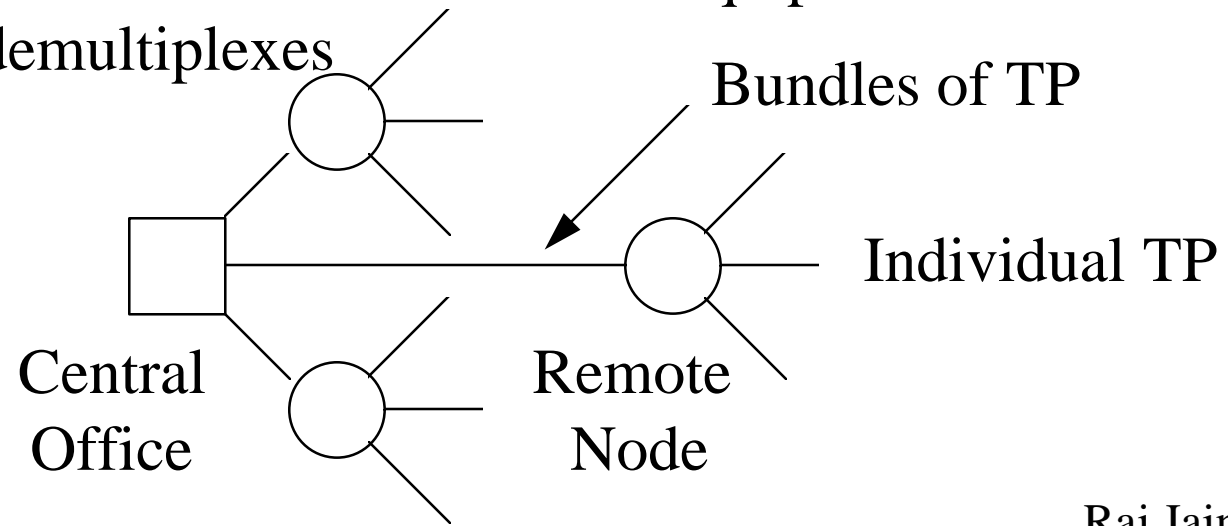

Circuit Switching

- ❑ Three Phases: Circuit setup, Signal Transfer, Circuit Disconnect
- ❑ Hierarchical System: Subscribers are connected to local exchanges (or end offices), which are connected via trunks to other tandem or toll switching centers.
- ❑ Routing can be static or adaptive.
Load independent or load dependent.

Signaling

- ❑ Signal = Control
- ❑ Signaling in telephone networks
= Control messages in computer networks
- ❑ Examples:
 - ❑ Connection setup request
= Off-hook signal from telephone to switch
 - ❑ Connection setup acknowledge = Dial tone
 - ❑ Destination address = Pulse or tone dialing
 - ❑ Destination busy = Busy tone
 - ❑ Destination Available = Ringing tone

Other Signaling Functions

- ❑ Transmission of dialed number between switches
- ❑ Transmission of information between switches indicating that a call cannot be completed
- ❑ Transmission of billing information
- ❑ Transmission of information for diagnosing and isolating failures
- ❑ Control of satellite channels

Types of Signaling Functions

- ❑ **Supervisory:** To obtain resources to establish/hold/release a connection. Includes information sent back to the subscriber's switch about the status of the call.
- ❑ **Address:** Identify destination. Subscriber to switch. Between switches.
- ❑ **Call information:** Provide call status to the calling subscriber
- ❑ **Network Management:** Operation, troubleshooting, and maintenance of the network. Not directly involved in call establishment/termination.
- ❑ Signaling between a subscriber and the network is different (simple) from that inside the network.

Signaling Channel

- ❑ In-band signaling \Rightarrow Signaling over the same channel as payload
- ❑ Out-of-band signaling \Rightarrow Separate channels for signaling (but may be same physical circuits)
- ❑ Common Channel Signaling (CCS)
 - \Rightarrow Separate circuits for signaling
 - \Rightarrow Allows several new functions, such as 800

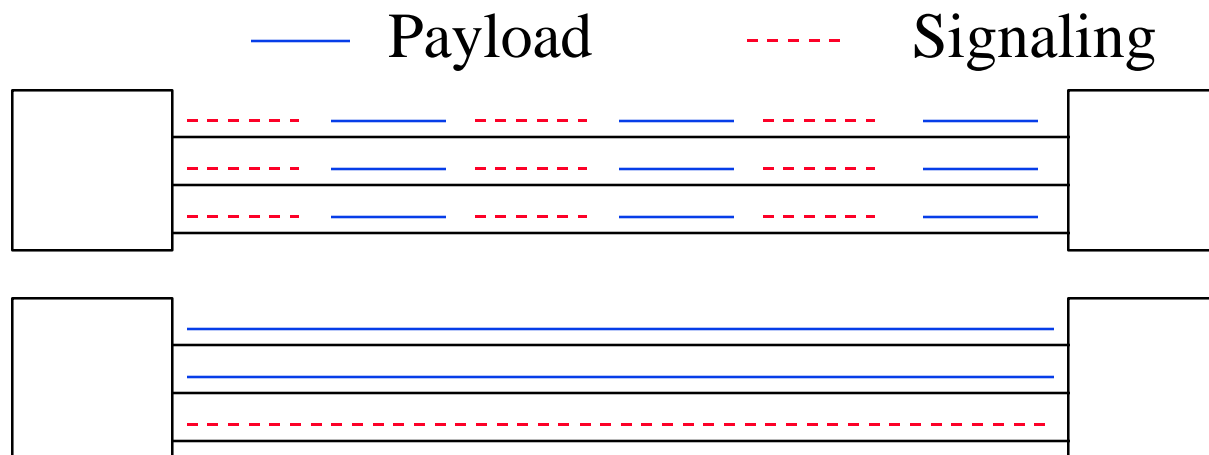

Signaling Modes

- ❑ Associated Mode: CCS follows the same path as payload
- ❑ Nonassociated Mode: CCS uses a separate network

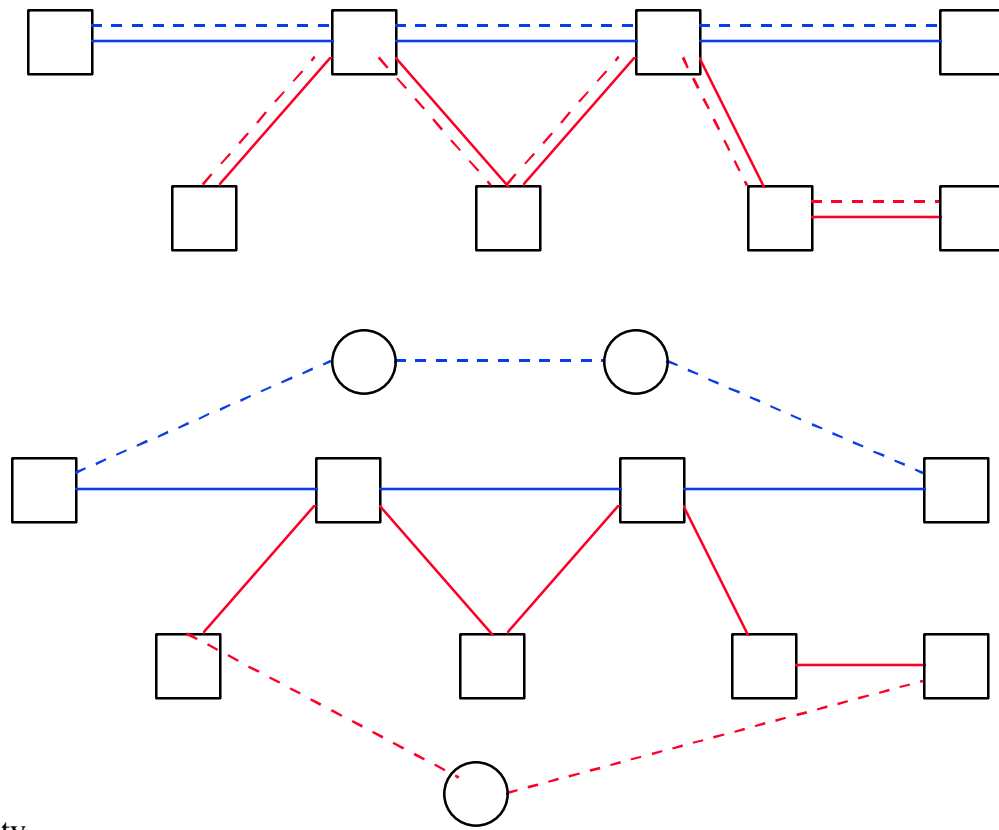

Summary

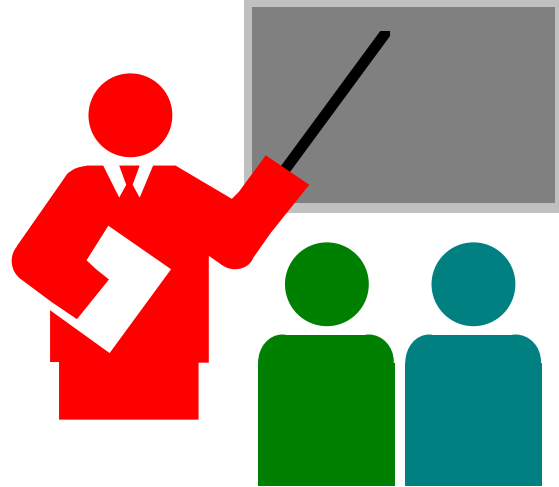

- ❑ T1, DS1, DS3, ...
- ❑ T1 Frames consist of 193 bits per 125 μ s.
- ❑ Echo cancellation is required if sharing the same wire-pair for both directions.
- ❑ Optical fiber can be used to replace feeder cable.
- ❑ Signaling: In band vs Common Channel, associated vs non-associated..

Homework

- ❑ Read chapter 2 and sections 3.1-3.5 of Stallings (ISDN and Broadband ISDN)
- ❑ Submit answer to exercise 2.7