

# Chapter 31

# Network Security

Raj Jain

The Ohio State University

Columbus, OH 43210

Jain@CIS.Ohio-State.Edu

<http://www.cis.ohio-state.edu/~jain/>



- ❑ Security Aspects
- ❑ Secret Key and Public Key Encryption
- ❑ Firewalls: Packet Filter, Bastion Host, Perimeter Nets
- ❑ Variations of firewalls
- ❑ Proxy servers

# Security Aspects

- ❑ Data Integrity: Received = sent?
- ❑ Data Availability: Legal users should be able to use. Ping continuously  $\Rightarrow$  No useful work gets done.
- ❑ Data Confidentiality and Privacy: No snooping or wiretapping
- ❑ Authentication: You are who you say you are. A student at Dartmouth posing as a professor canceled the exam.
- ❑ Authorization = Access Control: Only authorized users get to the data

# Secret Key Encryption

- ❑  $\text{Encrypted\_Message} = \text{Encrypt}(\text{Key}, \text{Message})$
- ❑  $\text{Message} = \text{Decrypt}(\text{Key}, \text{Encrypted\_Message})$
- ❑ Example: Encrypt = division
- ❑  $433 = 48 \text{ R } 1$  (using divisor of 9)

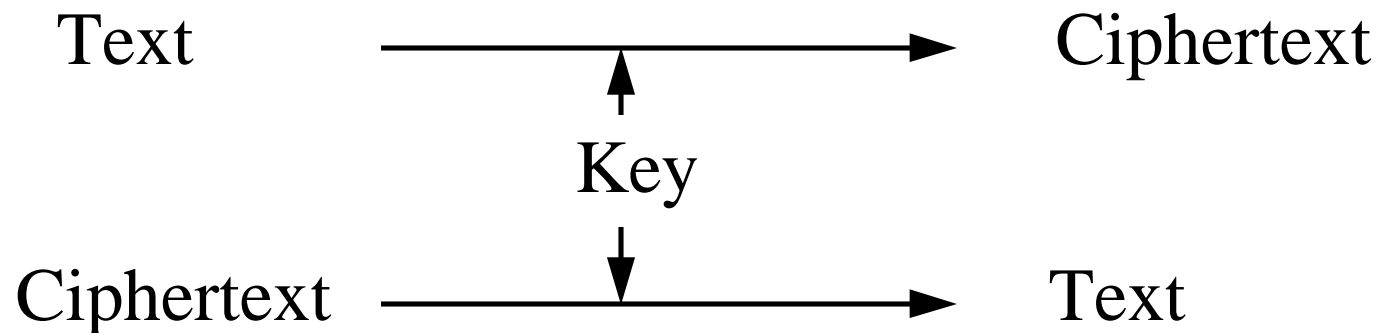

# Public Key Encryption

- ❑ Invented in 1975 by Diffie and Hellman
- ❑  $\text{Encrypted\_Message} = \text{Encrypt}(\text{Key1}, \text{Message})$
- ❑  $\text{Message} = \text{Decrypt}(\text{Key2}, \text{Encrypted\_Message})$

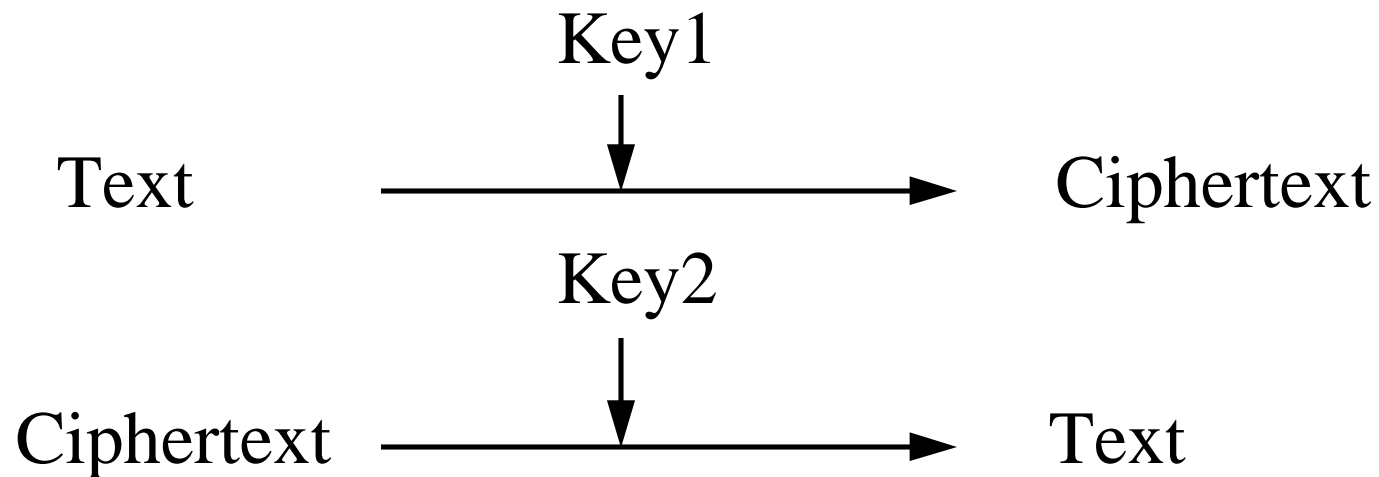

# Public Key Encryption: Example

- ❑ RSA: Encrypted\_Message =  $m^3 \bmod 187$
- ❑ Message = Encrypted\_Message<sup>107</sup> mod 187
- ❑ Key1 =  $\langle 3, 187 \rangle$ , Key2 =  $\langle 107, 187 \rangle$
- ❑ Message = 5
- ❑ Encrypted Message =  $5^3 = 125$
- ❑ Message =  $125^{107} \bmod 187$   
=  $125^{(64+32+8+2+1)} \bmod 187$   
=  $(125^{64} \bmod 187)(125^{32} \bmod 187) \dots$   
 $(125^2 \bmod 187)(125)$   
= 5

## Public Key (Cont)

- ❑ One key is private and the other is public
- ❑ Message = Decrypt(Public\_Key, Encrypt(Private\_Key, Message))
- ❑ Message = Decrypt(Private\_Key, Encrypt(Public\_Key, Message))

# Digital Signature

- ❑ Encrypted\_Message  
= Encrypt(Private\_Key, Message)
- ❑ Message = Decrypt(Public\_Key, Encrypted\_Message)  
⇒ Authentic

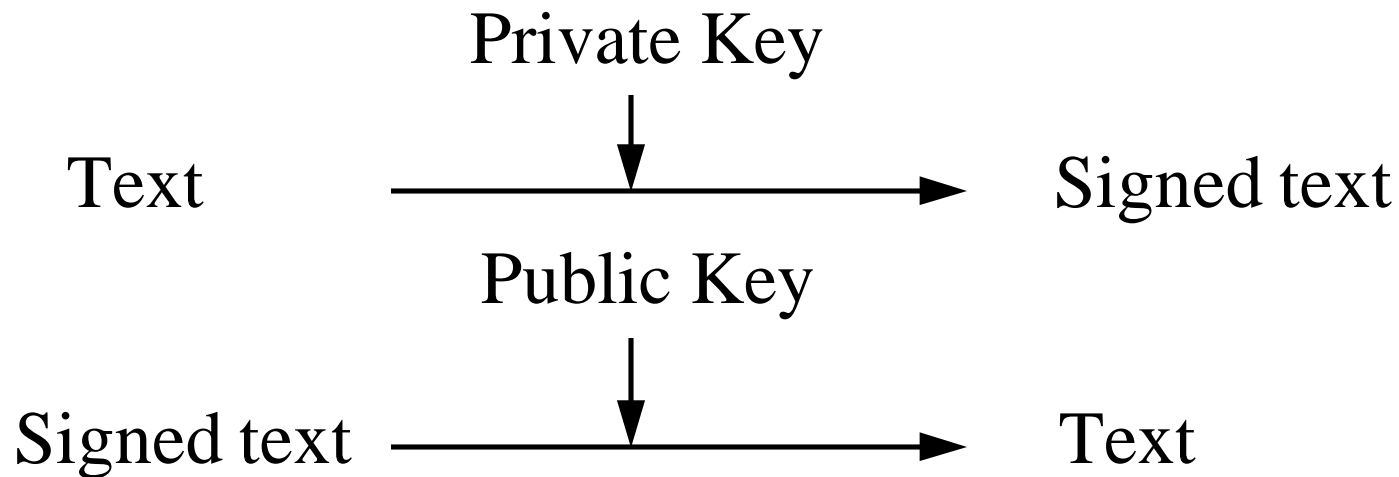

# Confidentiality

- ❑ User 1 to User 2:
- ❑  $\text{Encrypted\_Message} = \text{Encrypt}(\text{Public\_Key2}, \text{Encrypt}(\text{Private\_Key1}, \text{Message}))$
- ❑  $\text{Message} = \text{Decrypt}(\text{Public\_Key1}, \text{Decrypt}(\text{Private\_Key2}, \text{Encrypted\_Message}))$   
 $\Rightarrow$  Authentic and Private



# Simple Firewall: Packet Filter

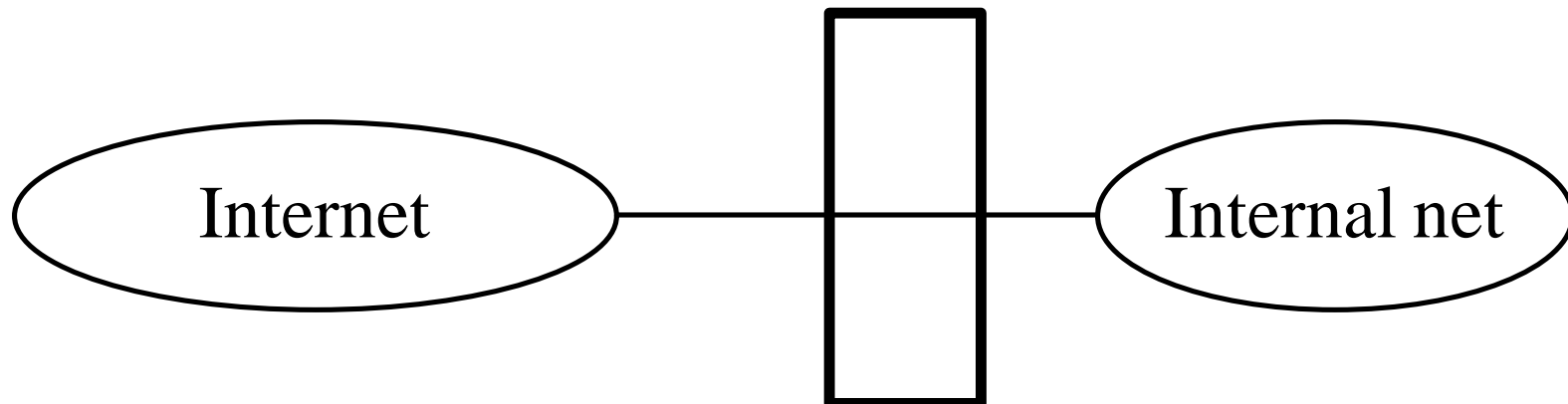

- ❑ Example: Only email gets in/out ftp to/from nodes x, y, z, etc.
- ❑ Problem: Filter is accessible to outside world

## Filter Table: Example

Interface	Source	Dest	Prot.	Src Port	Dest Port
2	*	*	TCP	*	21
2	*	*	TCP	*	23
1	128.5.*.*	*	TCP	*	25
2	*	*	UDP	*	43
2	*	*	UDP	*	69
2	*	*	TCP	*	79

## Bastion Host

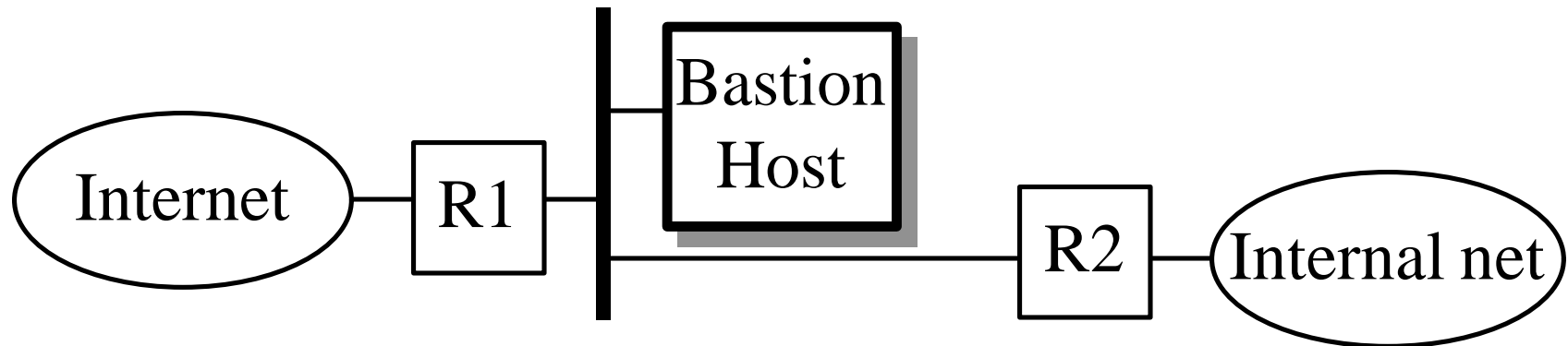

- ❑ Bastions overlook critical areas of defense, usually having stronger walls
- ❑ Inside users need a mechanism to get outside services
- ❑ Inside users log on the Bastion Host and use outside services.
- ❑ Later they pull the results inside.

## Bastion Host (Cont)

- ❑ Perimeter Network: Outside snoopers cannot see internal traffic even if they break in the firewall (Router 2)
- ❑ Also known as "Stub network"

# Screened Host Architecture

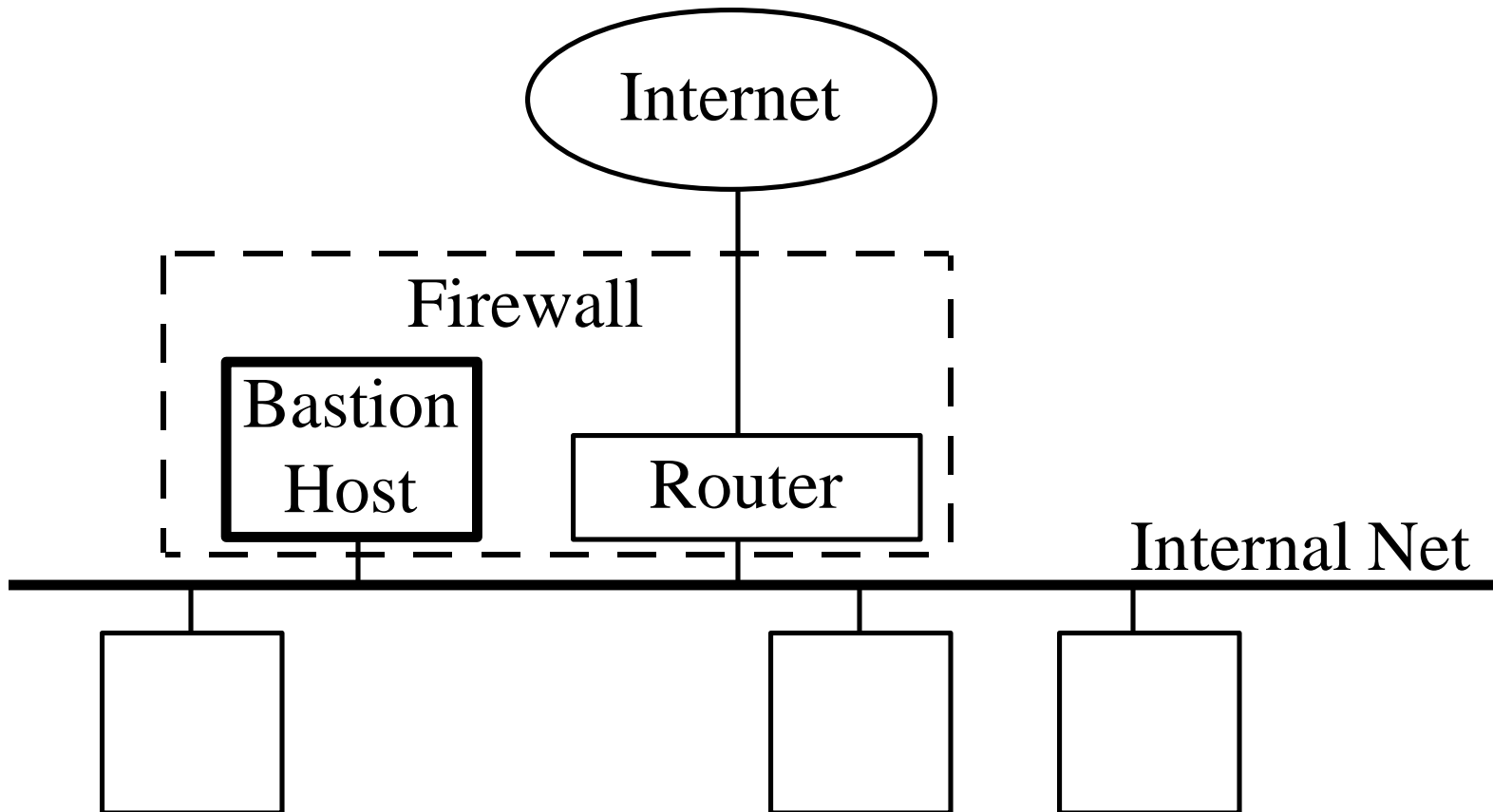

# Screened subnet Architecture

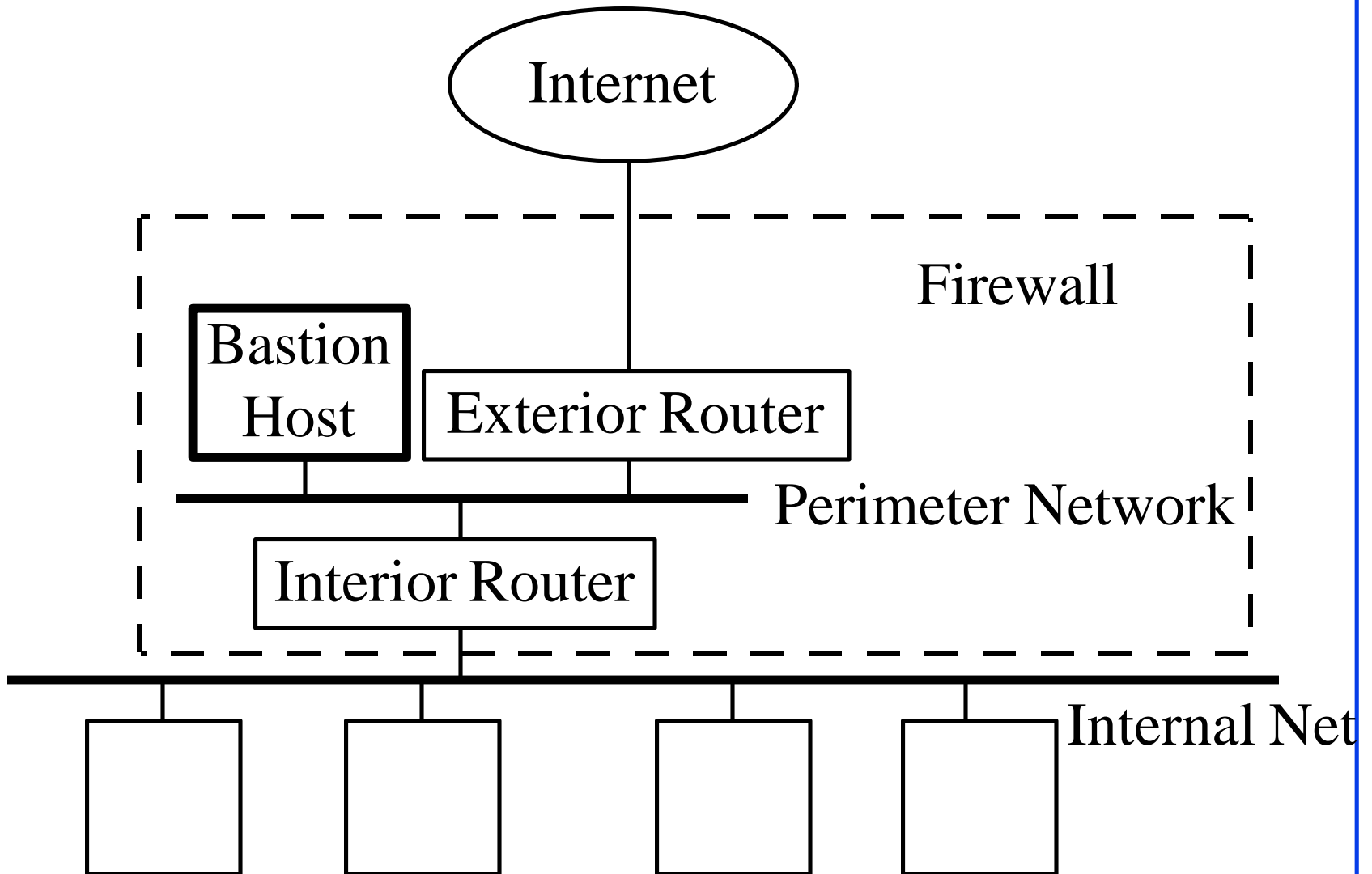

# Multiple Bastion Hosts

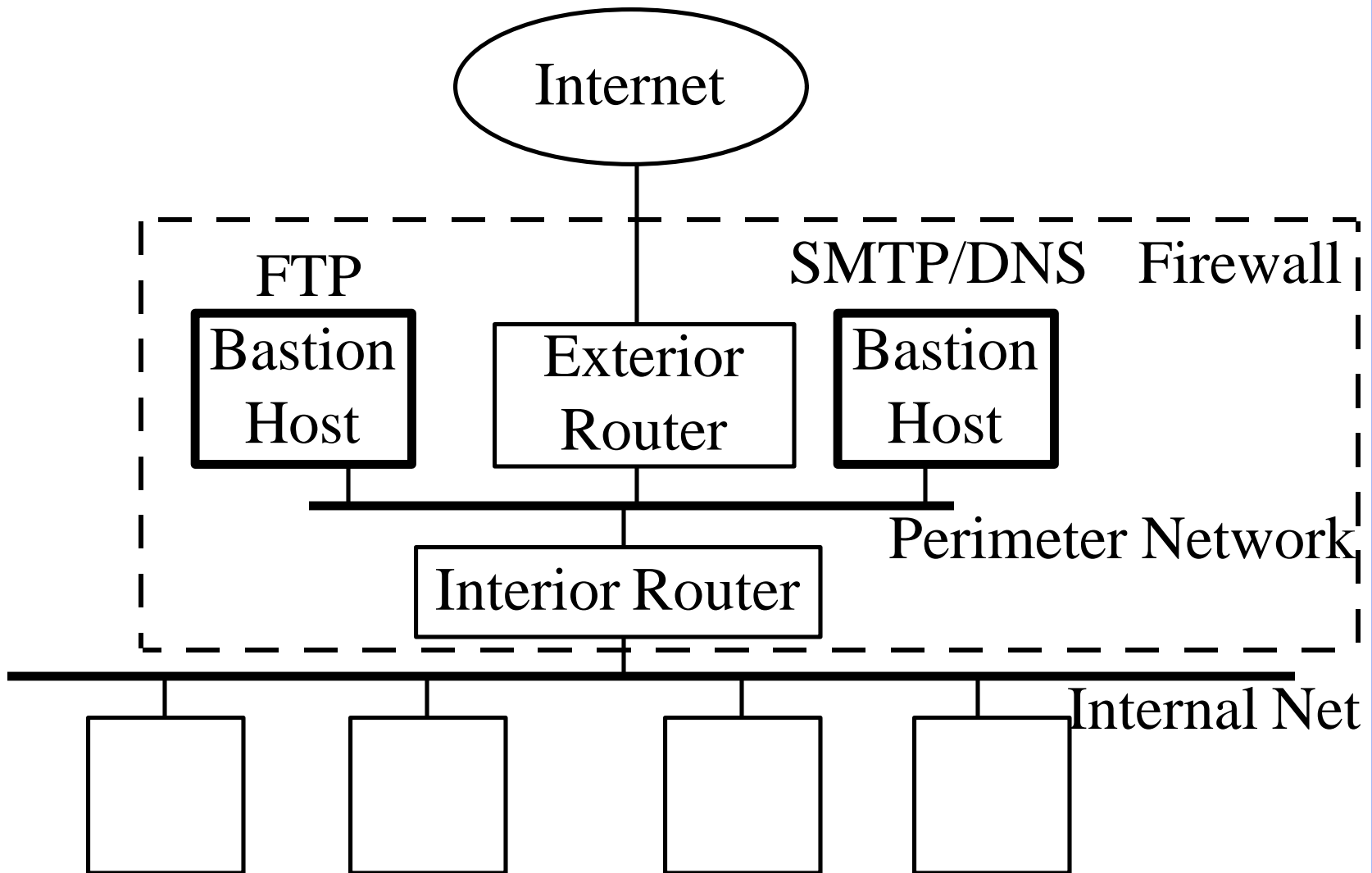

# Merged Interior and Exterior Routers

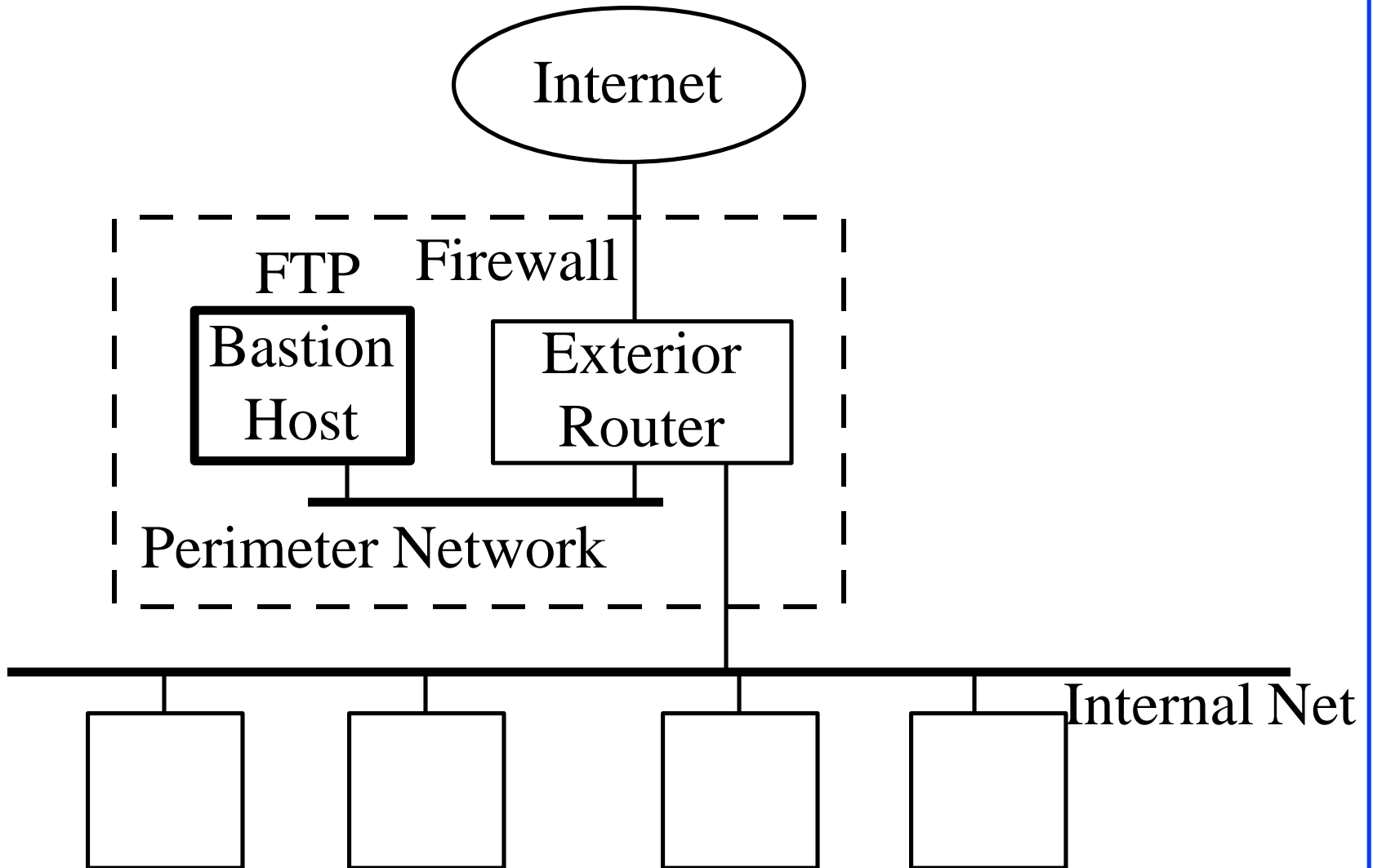

# Merged Bastion Host and Exterior Router

- Also known as a dual-homed gateway

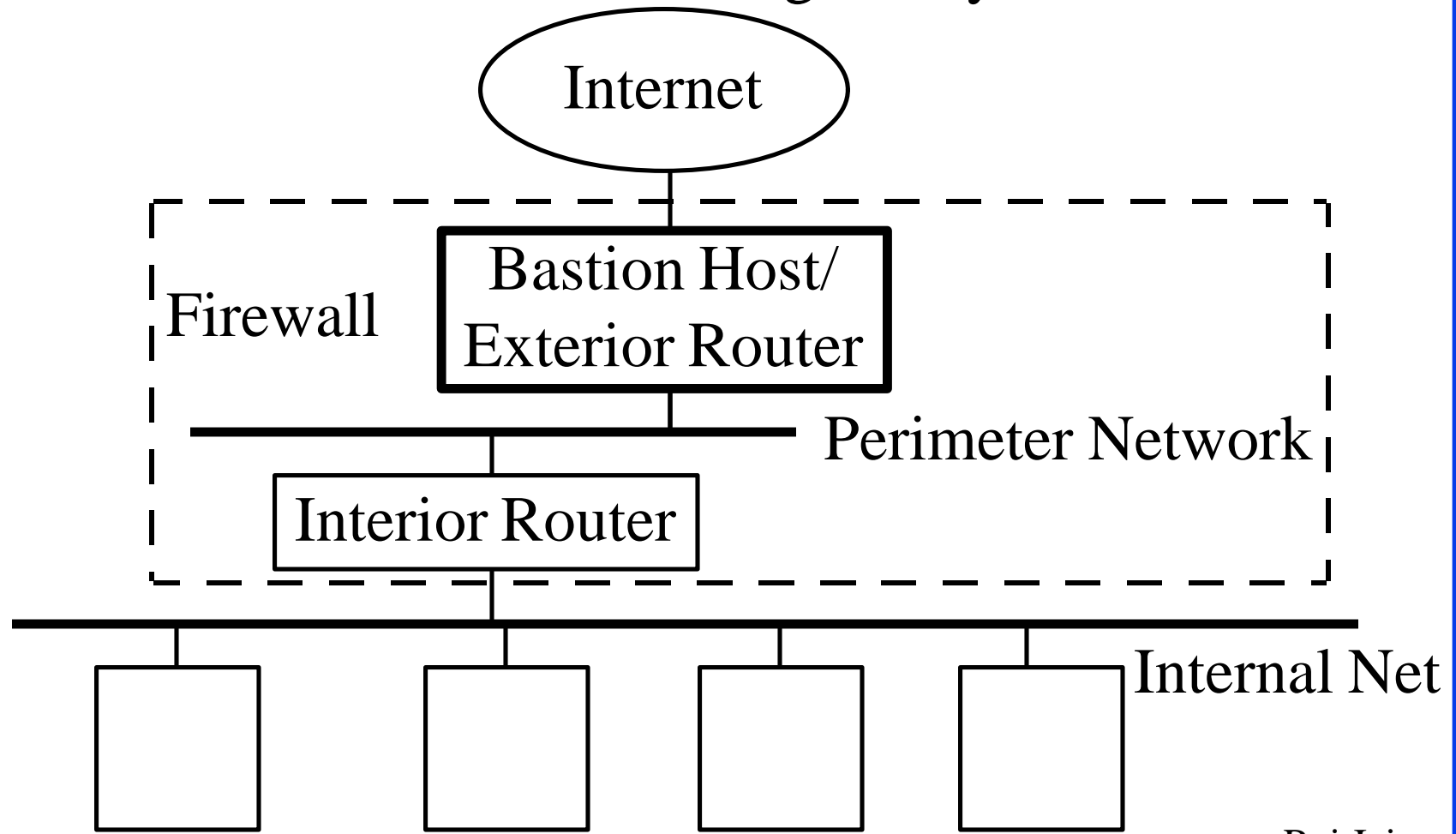

# Dual-Homed Host Architecture

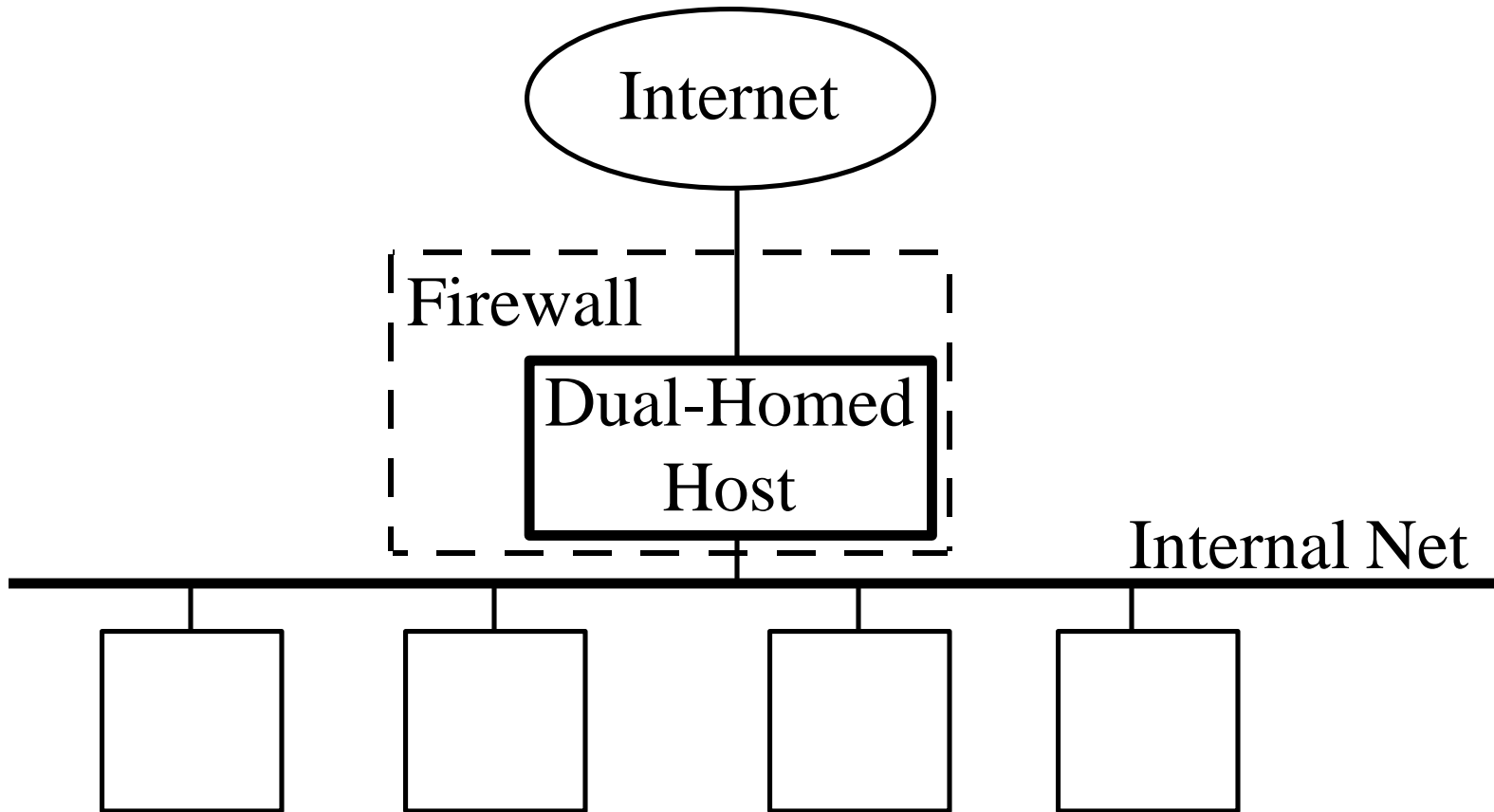

# Merged Bastion Host and Interior Router (Not Recommended)

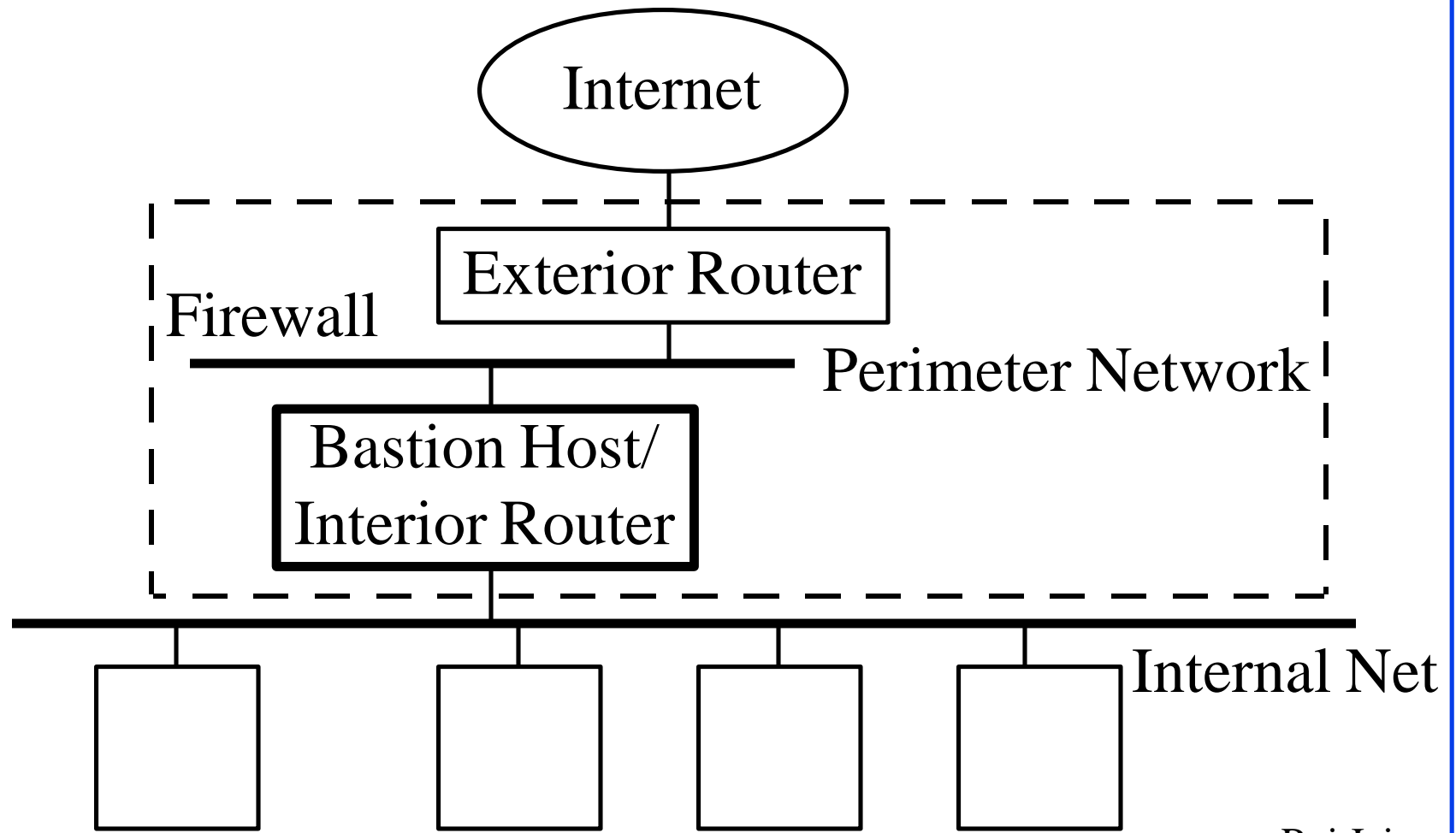

# Multiple Interior Routers

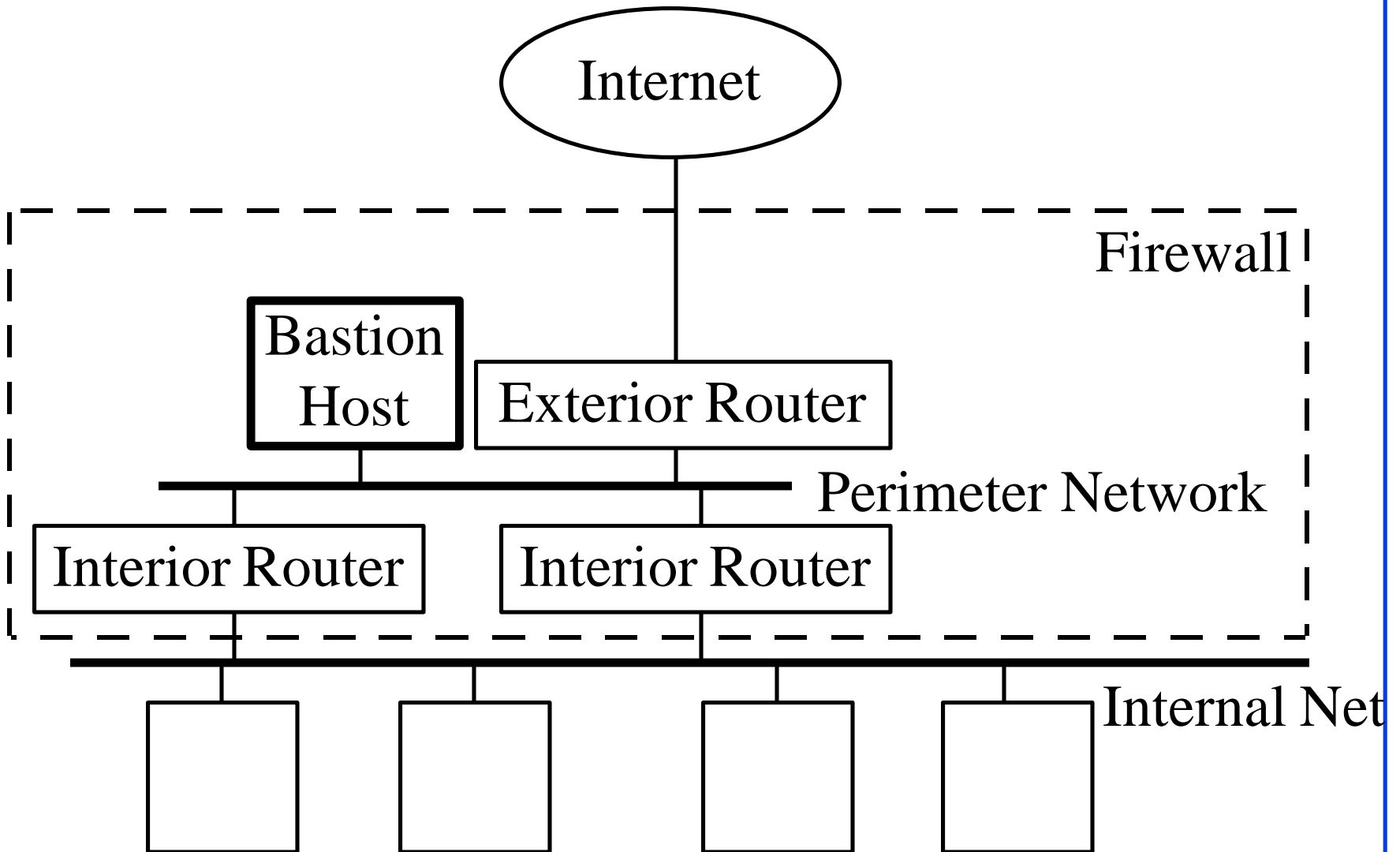

# Multiple Internal Networks

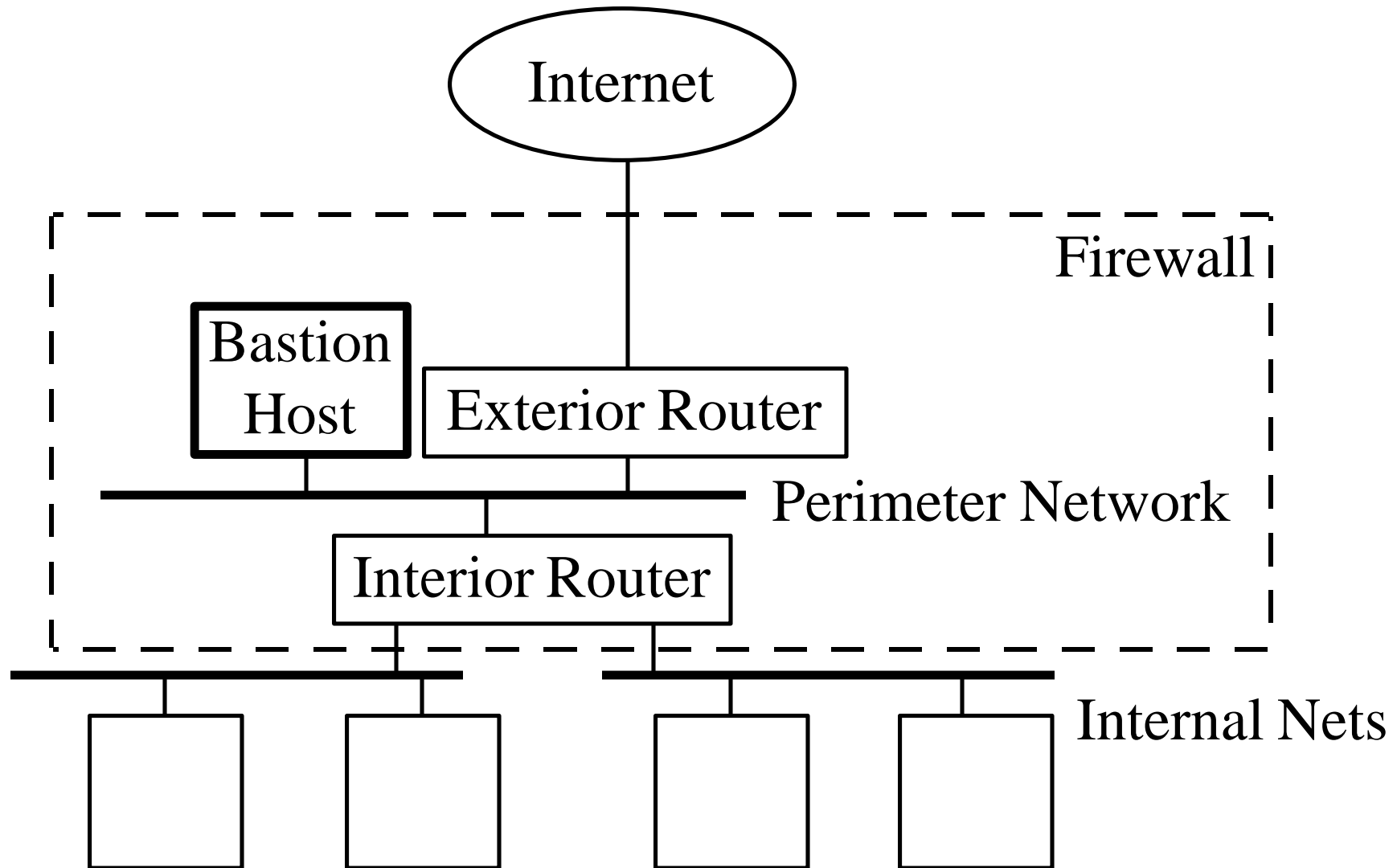

# Multiple Internal Networks with a Backbone

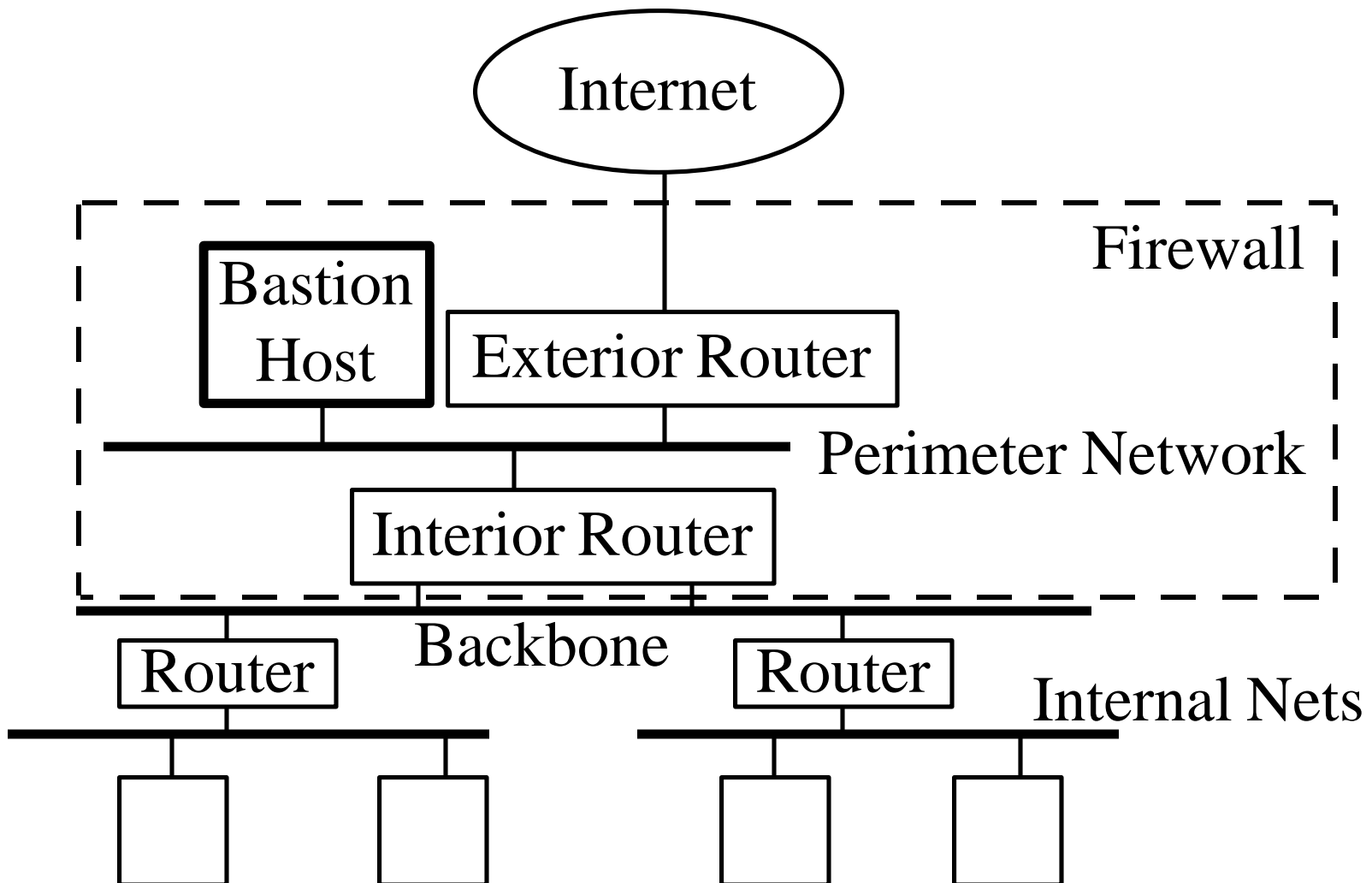

# Multiple Exterior Routers

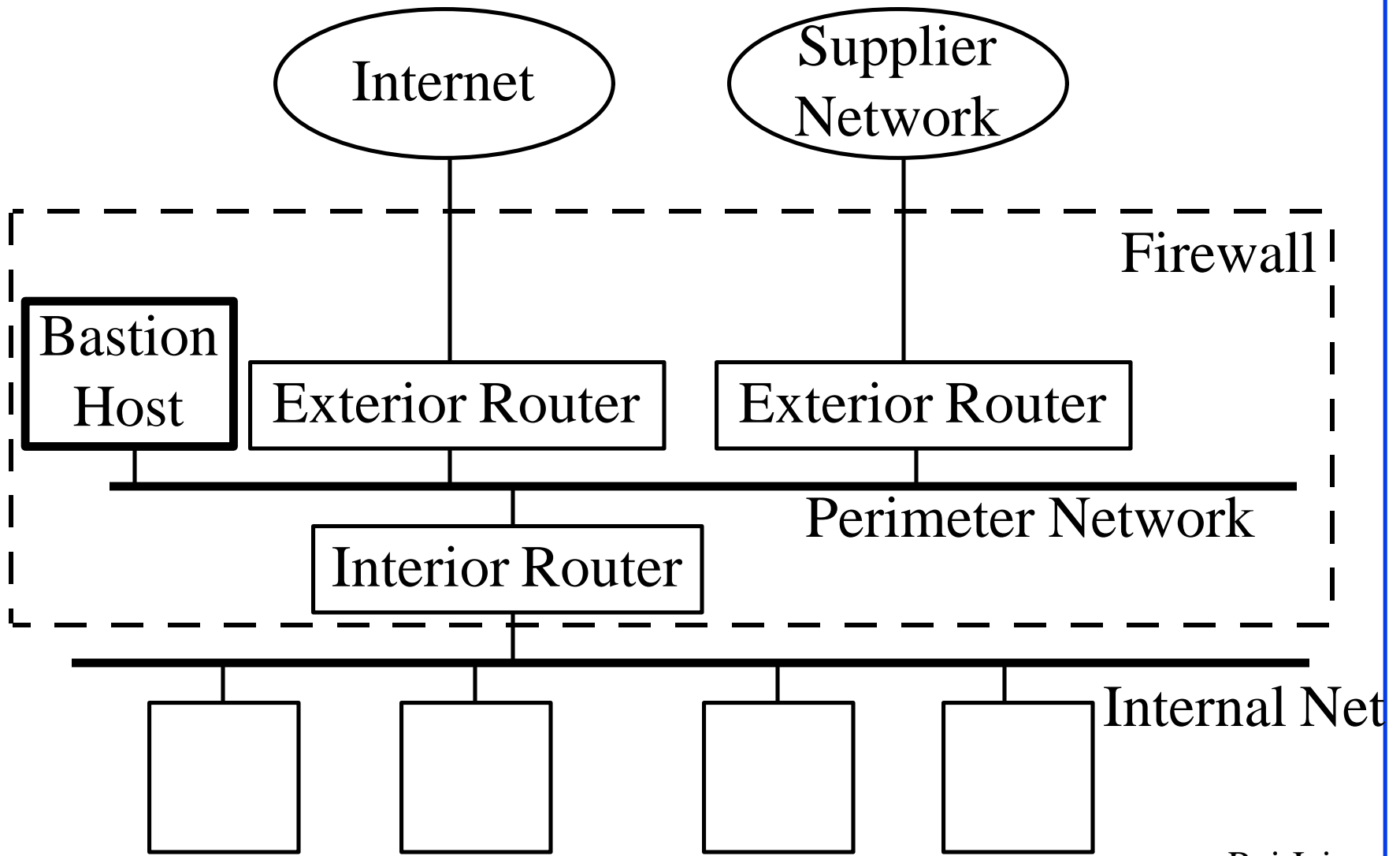

# Multiple Perimeter Networks

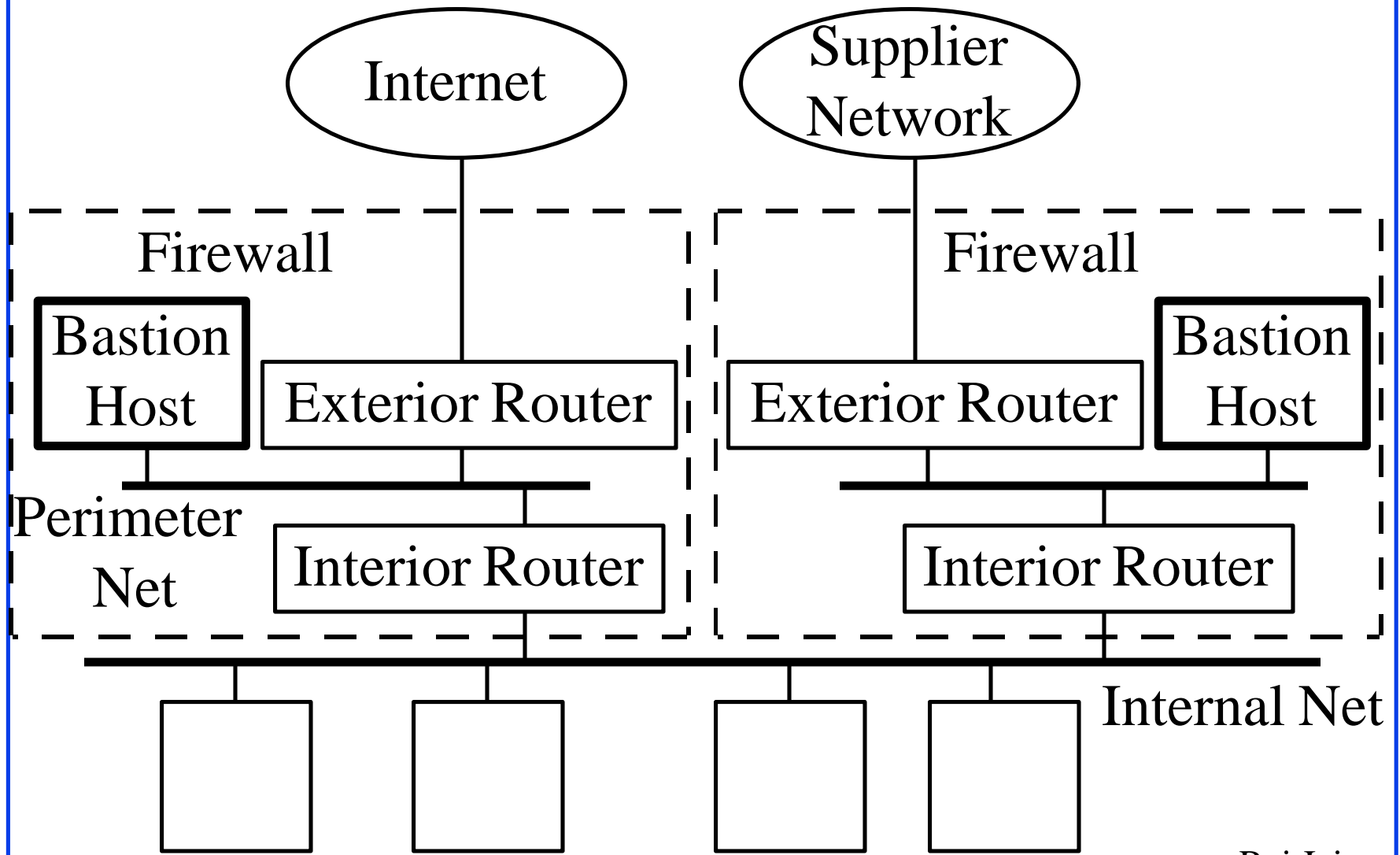

# Proxy Servers

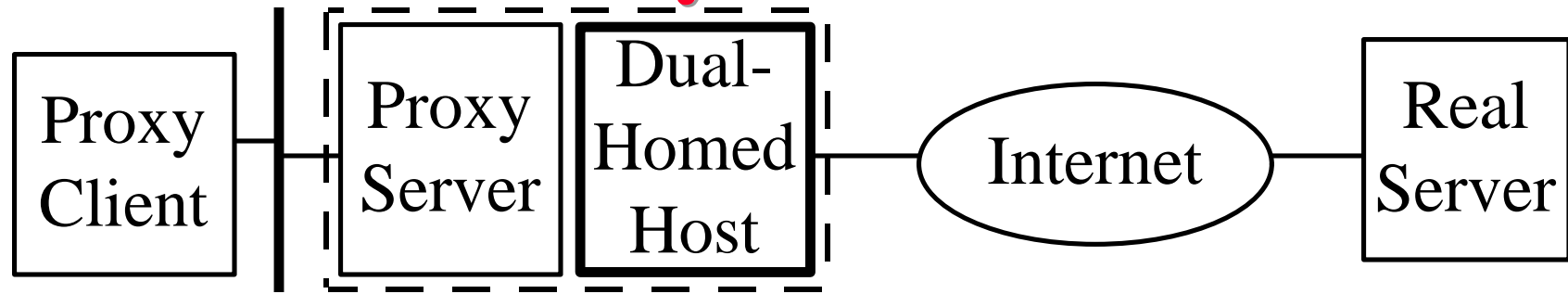

- ❑ Specialized server programs on bastion host
- ❑ Take user's request and forward them to real servers
- ❑ Take server's responses and forward them to users
- ❑ Enforce site security policy  $\Rightarrow$  May refuse certain requests.
- ❑ Also known as application-level gateways
- ❑ With special "Proxy client" programs, proxy servers are almost transparent

# What Firewalls Can't Do

- ❑ Can't protect against malicious insiders
- ❑ Can't protect against connections that do not go through it, e.g., dial up
- ❑ Can't protect completely new threats
- ❑ Can't protect against viruses

# Security Mechanisms on The Internet

- ❑ Kerberos
- ❑ Privacy Enhanced Mail (PEM)
- ❑ Pretty Good Privacy (PGP)
- ❑ MD5

# Summary

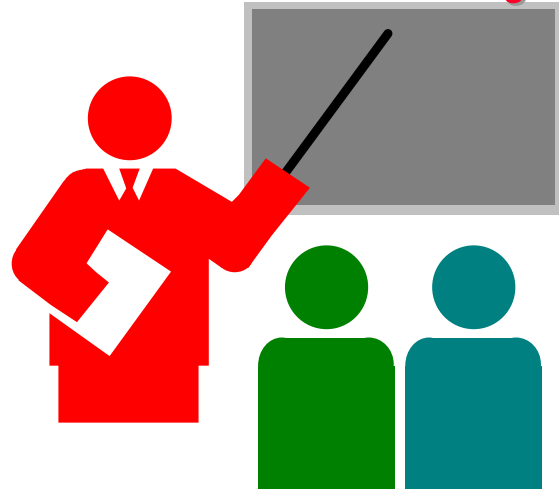

- ❑ Integrity, Availability, Authentication, Confidentiality
- ❑ Private Key and Public Key encryption
- ❑ Packet filter, Bastion node, perimeter network, internal and external routers

# Homework

- ❑ Read Chapter 31
- ❑ Submit answer to Exercise 31.3

# References

- ❑ D. B. Chapman and E. D. Zwicky, “Building Internet Firewalls,” O’Reilly & Associates, 1995
- ❑ D. E. Comer, “Internetworking with TCP/IP,” Vol. 1, 3rd Ed, Prentice Hall, 1995, Chapter 28.
- ❑ C. Kaufman, R. Perlman, M. Speciner, “Network Security,” Prentice-Hall, 1995.
- ❑ Coast Security Project at Purdue University  
<http://www.cs.purdue.edu/coast/coast.html>

# Security: RFCs

- ❑ [RFC1848] S. Crocker, N. Freed, J. Galvin, S. Murphy, "MIME Object Security Services", 10/03/1995, 48 pages.
- ❑ [RFC1847] J. Galvin, S. Murphy, S. Crocker, N. Freed, "Security Multiparts for MIME: Multipart/Signed and Multipart/Encrypted", 10/03/1995, 11 pages.
- ❑ [RFC1108] S. Kent, "U.S. Department of Defense Security Options for the Internet Protocol", 11/27/1991, 17 pages.
- ❑ [RFC1244] P. Holbrook, J. Reynolds, "Site Security Handbook", 07/23/1991, 101 pages. (FYI 8)
- ❑ [RFC1352] J. Davin, J. Galvin, K. McCloghrie, "SNMP Security Protocols", 07/06/1992, 41 pages.
- ❑ [RFC1446] J. Galvin, K. McCloghrie, "Security Protocols for version 2 of the Simple Network Management Protocol (SNMPv2)", 05/03/1993, 51 pages.

- ❑ [RFC1455] D. Eastlake, III, "Physical Link Security Type of Service", 05/26/1993, 6 pages.
- ❑ [RFC1457] R. Housley, "Security Label Framework for the Internet", 05/26/1993, 14 pages.
- ❑ [RFC1472] F. Kastenholtz, "The Definitions of Managed Objects for the Security Protocols of the Point-to-Point Protocol", 06/08/1993, 11 pages.
- ❑ [RFC1507] C. Kaufman, "DASS - Distributed Authentication Security Service", 09/10/1993, 119 pages.
- ❑ [RFC1509] J. Wray, "Generic Security Service API : C-bindings", 09/10/1993, 48 pages.
- ❑ [RFC1535] E. Gavron, "A Security Problem and Proposed Correction With Widely Deployed DNS Software", 10/06/1993, 5 pages.
- ❑ [RFC1636] I. Architecture Board, R. Braden, D. Clark, S. Crocker, C. Huitema, "Report of IAB Workshop on Security in the Internet Architecture - February 8-10, 1994", 06/09/1994, 52 pages.
- ❑ [RFC1675] S. Bellovin, "Security Concerns for IPng", 08/08/1994, 4 pages.
- ❑ [RFC1750] D. Eastlake, S. Crocker, J. Schiller, "Randomness Recommendations for Security", 12/29/1994, 25 pages.

- ❑ [RFC1824] H. Danisch, "The Exponential Security System TESS: An Identity-Based Cryptographic Protocol for Authenticated Key-Exchange (E.I.S.S.-Report 1995/4)", 08/11/1995, 21 pages.
- ❑ [RFC1825] R. Atkinson, "Security Architecture for the Internet Protocol", 08/09/1995, 22 pages.
- ❑ [RFC1827] R. Atkinson, "IP Encapsulating Security Payload (ESP)", 08/09/1995, 12 pages.
- ❑ [RFC1858] P. Ziemba, D. Reed, P. Traina, "Security Considerations for IP Fragment Filtering", 10/25/1995, 10 pages.
- ❑ [RFC1910] G. Waters, "User-based Security Model for SNMPv2", 02/28/1996, 44 pages.
- ❑ [RFC2015] M. Elkins, "MIME Security with Pretty Good Privacy (PGP)", 10/14/1996, 8 pages.
- ❑ [RFC2065] D. Eastlake, C. Kaufman, "Domain Name System Security Extensions", 01/03/1997, 41 pages. (Updates RFC1034)
- ❑ [RFC2078] J. Linn, "Generic Security Service Application Program Interface, Version 2", 01/10/1997, 85 pages.

- [RFC2084] G. Bossert, S. Cooper, W. Drummond, "Considerations for Web Transaction Security", 01/22/1997, 6 pages.