

Chapter 1: Introduction

Raj Jain
Professor of CIS
The Ohio State University
Columbus, OH 43210
Jain@ACM.Org
<http://www.cis.ohio-state.edu/~jain/>

Data Communication vs Networking

- Communication: Two Nodes. Mostly EE issues.

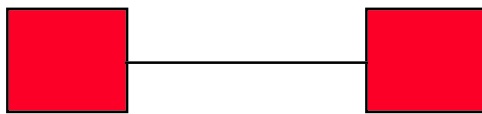

- Networking: Two or more nodes. More issues, e.g., routing

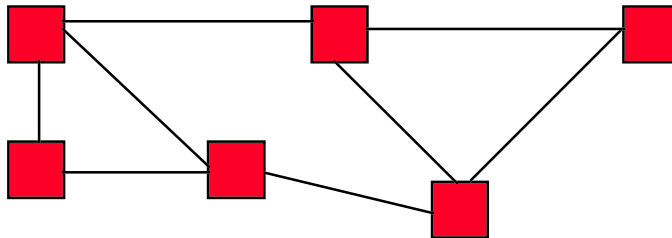

Distributed Systems vs Networks

- Distributed Systems:
 - Users are unaware of underlying structure.
E.g., trn instead of \\\bone\\0\\trn
 - Mostly operating systems issues.
 - Nodes are generally under one organization's control.
- Networks: Users specify the location of resources.
<http://www.cis.ohio-state.edu/~jain/>
 - Nodes are autonomous.

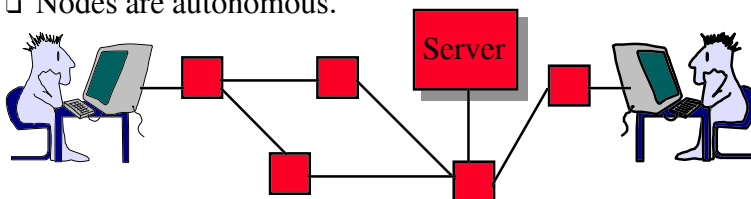

The Ohio State University

Raj Jain

1B-3

Types of Networks

- Point to point vs Broadcast

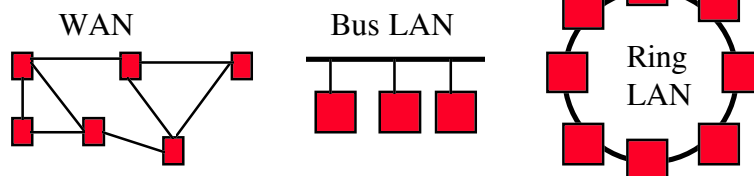

- Circuit switched vs packet switched

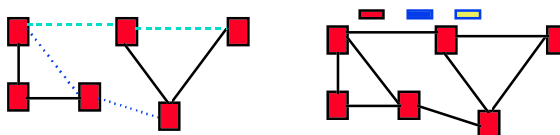

- Local Area Networks (LAN) 0-2 km, Metropolitan Area Networks (MAN) 2-50 km, Wide Area Networks (WAN) 50+ km

The Ohio State University

Raj Jain

1B-4

Protocol Layers

- Problem: Philosophers in different countries speak different languages. The Telex system works only with English.

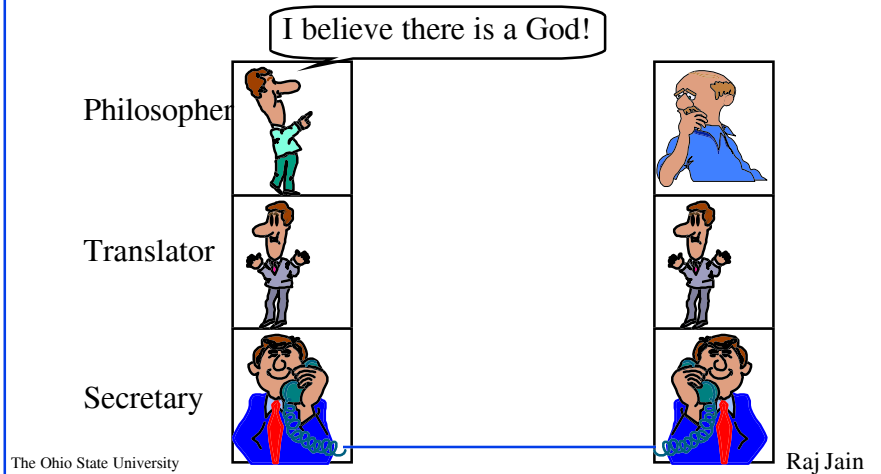

1B-5

Design Issues for Layers

- Duplexity:
 - Simplex: Transmit or receive
-
- Full Duplex: Transmit and receive simultaneously
 - Half-Duplex: Transmit and receive alternately
 - Error Control: Error detection and retransmission
 - Flow Control: Fast sender

The Ohio State University

Raj Jain

1B-6

ISO/OSI Reference Model

3	Application	File transfer, Email, Remote Login
	Presentation	ASCII Text, Sound
	Session	Establish/manage connection
2	Transport	End-to-end communication: TCP
	Network	Routing, Addressing: IP
1	Datalink	Two party communication: Ethernet
	Physical	How to transmit signal: Coding

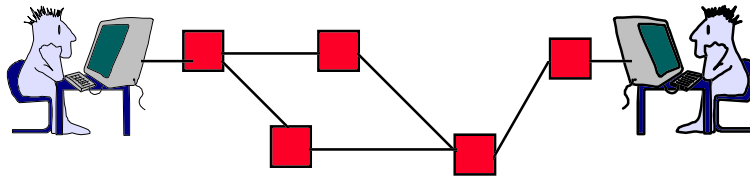

The Ohio State University

Raj Jain

1B-7

Layering

FTP	Telnet	Web	Email
TCP		UDP	
IP		IPX	
Ethernet		Token Ring	
Copper		Fiber	

← Same Interfaces

- Protocols of each layer have to perform a set of functions
- All alternatives for a row have the same interfaces
- Choice of protocols at each layer is independent of those of at other layers. E.g., TCP works over IP or IPX (Novell's IP)
UDP = User Data Protocol
- Need one component of each layer ⇒ Null components
- Nth layer control info is passed as N-1th layer data.

The Ohio State University

Raj Jain

1B-8

Interfaces and Services

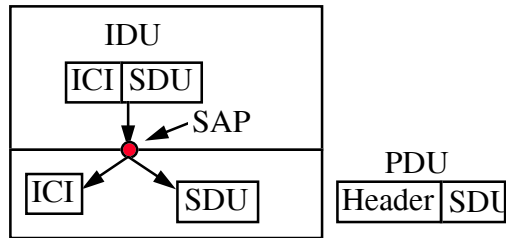

- ❑ IDU = Interface Data Unit = ICI + SDU
- ❑ ICI = Interface Control Information
- ❑ SDU = Service Data Unit
- ❑ PDU = Protocol Data Unit = Fragments of SDU + Header or Several SDUs + Header (blocking)

Protocol Data Unit (PDU)

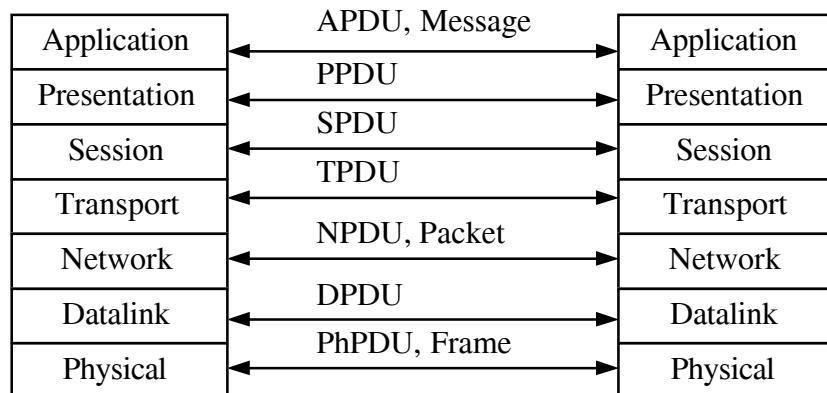

Service Data Unit (SDU)

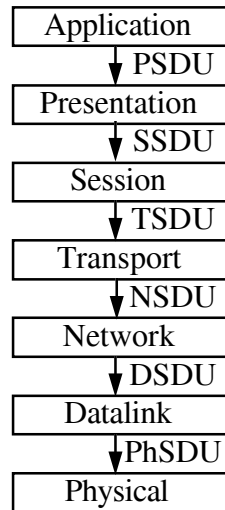

Connection-Oriented vs Connectionless

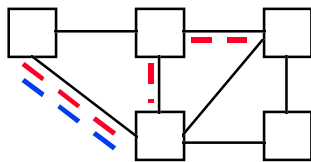

- Connection-Oriented: Telephone System
 - Path setup before data is sent
 - Data need not have address. Circuit number is sufficient.
 - Virtual circuits: Multiple circuits on one wire.
- Connectionless: Postal System. Also known as datagram.
 - Complete address on each packet
 - The address decides the next hop at each routing point

Types of Services

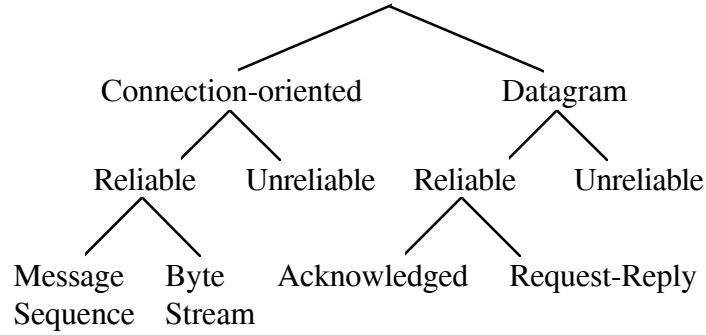

- Byte streams: user message boundaries are not preserved
- Request-reply: The reply serves as an acknowledgement also

Service Primitives

- Indication = Interrupt

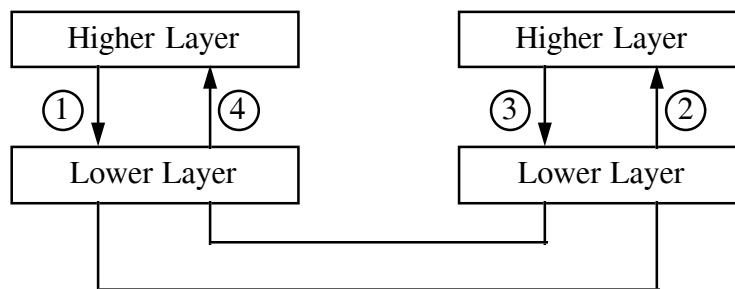

1. Connect.Request
2. Connect.Indication
3. Connect.Confirm
4. Connect.Response

Unconfirmed service: No confirmation or response

TCP/IP Reference Model

- ❑ TCP = Transport Control Protocol
- ❑ IP = Internet Protocol (Routing)

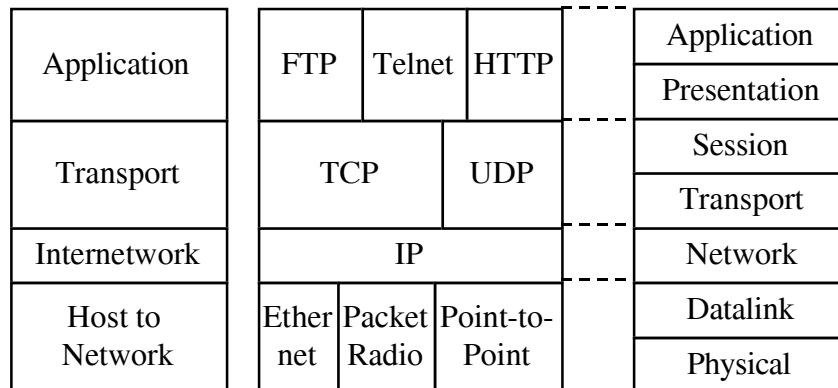

OSI vs TCP Reference Models

- ❑ OSI introduced concept of services, interface, protocols
These were force-fitted to TCP later
⇒ It is not easy to replace protocols in TCP.
- ❑ In OSI, reference model was done before protocols.
In TCP, protocols were done before the model
- ❑ OSI: Standardize first, build later
TCP: Build first, standardize later
- ❑ OSI took too long to standardize. TCP/IP was already in wide use by the time.
- ❑ OSI become too complex.
- ❑ TCP/IP is not general. Ad hoc.

Summary

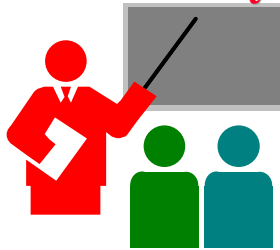

- Networking is growing exponentially
- Communication, Networks, and Distributed systems
- ISO/OSI's 7-layer reference model
- TCP/IP has a 4-layer model
- PDU, SAP, Request, Indication

Reading Assignment

- Read Chapter 1 of Tanenbaum, particularly, Sections 1.2-1.4
- Homework: Problems 9, 17