

# Fundamentals of Networking

Raj Jain

Professor of CIS  
The Ohio State University  
Columbus, OH 43210  
Jain@ACM.Org

<http://www.cis.ohio-state.edu/~jain/>

## Trend: Networking is Critical

- ❑ Communication more critical than computing
  - ⇒ Bus performance vs ALU speed
  - ⇒ I/O performance vs SPECMarks
- ❑ User Location:
  - ❑ 1960: Computer room                      1970: Terminal room
  - ❑ 1980: Desktop                                1990: Mobile
- ❑ System Extent:
  - ❑ 1980: 1 Node within 10 m
  - ❑ 1990: 100 nodes within 10 km

- ❑ Last 10 years: Individual computing  
Next 10 years: Cooperative computing
- ❑ Past: Corporate networks  
Future:
  - ❑ Inter-corporate networks
  - ❑ National Info Infrastructures
  - ❑ International Info Infrastructures

### Trend: Exponential Growth

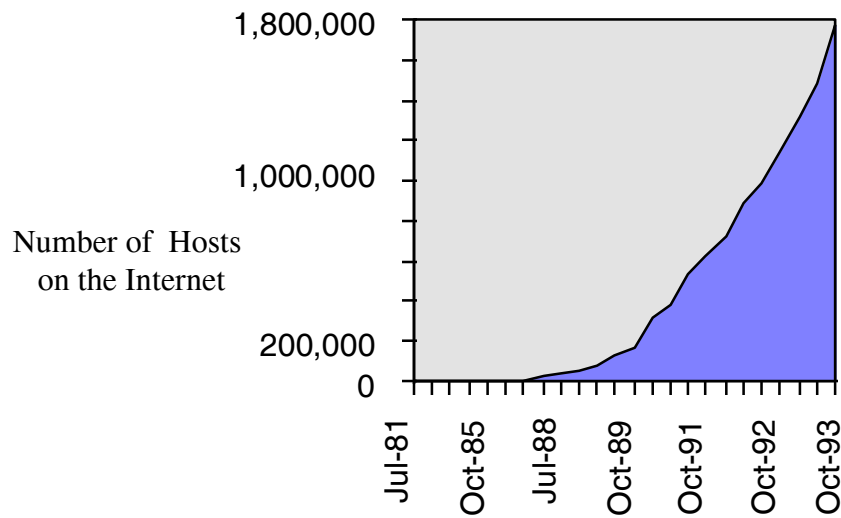

## Networking in Social Fabric

- USENET: Ten million news articles/month
- 18 on-line coffee houses in San Francisco
- National Public Radio Program
- Supreme court decision within one day
- Real estate, on-line catalog
- 137 countries reachable via Email

## Data Communication vs Networking

- Communication: Two Nodes.

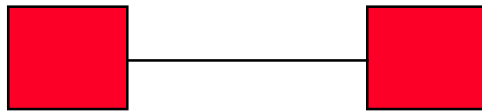

- Networking: Two or more nodes

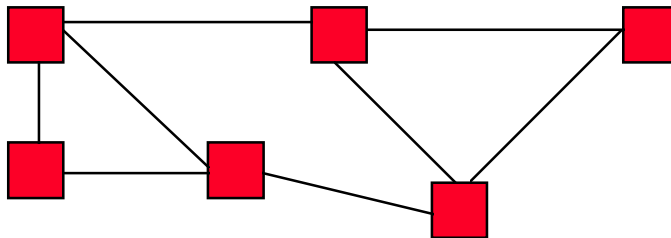

## Distributed Systems vs Networks

- Distributed Systems:
  - Users are unaware of underlying structure.  
E.g., trn instead of \n\bone\0\trn
  - Mostly operating systems issues.
  - Nodes are generally under one organization's control.
- Networks: Users specify the location of resources.  
<http://www.cis.ohio-state.edu/~jain/>
  - Nodes are autonomous.

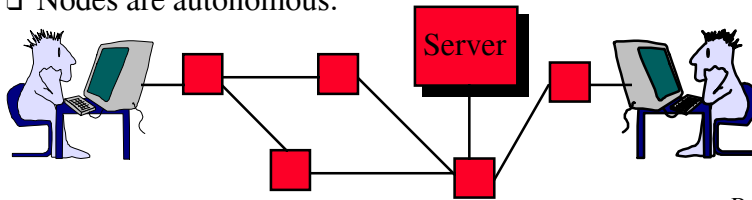

The Ohio State University

Raj Jain

1B-9

## Types of Networks

- Point to point vs Broadcast

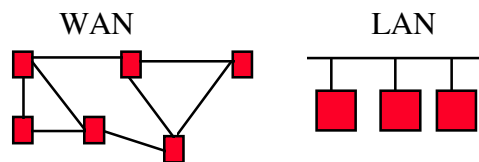

- Circuit switched vs packet switched

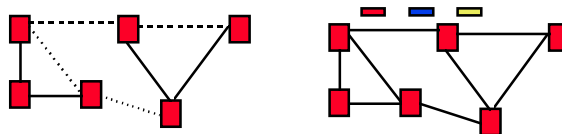

- Local Area Networks (LAN) 0-2 km, Metropolitan Area Networks (MAN) 2-50 km, Wide Area Networks (WAN) 50+ km

The Ohio State University

Raj Jain

1B-10

## Protocol Layers

- Problem: Philosophers in different countries speak different languages. The Telex system works only with English.

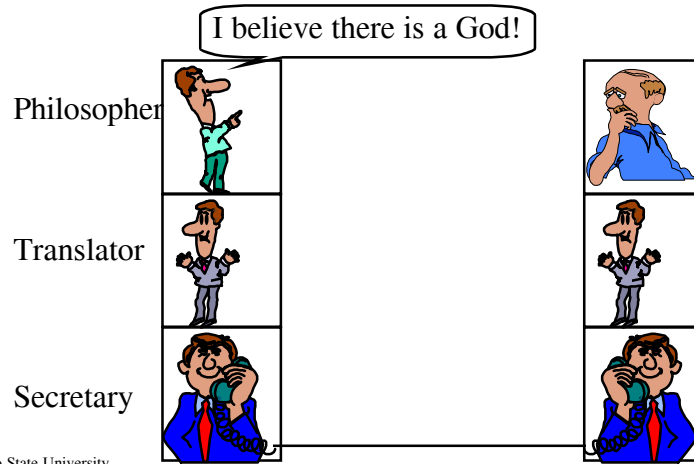

The Ohio State University

Raj Jain

1B-11

## ISO/OSI Reference Model

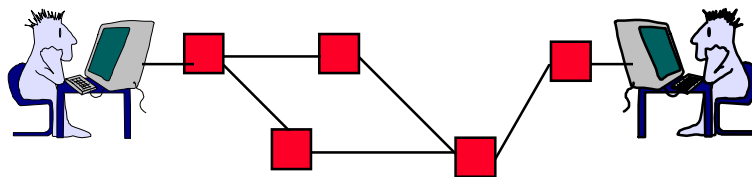
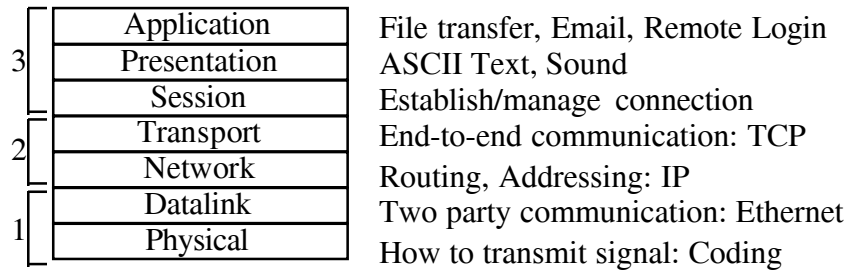

The Ohio State University

Raj Jain

1B-12

## Layering

FTP	Telnet	Web	Email
TCP		UDP	
IP		IPX	
Ethernet		Token Ring	
Copper		Fiber	

← Same  
Interfaces

- ❑ Protocols of each layer have to perform a set of functions
- ❑ All alternatives for a row have the same interfaces
- ❑ Choice of protocols at each layer is independent of those of at other layers. E.g., TCP works over IP or IPX (Novell's IP)  
UDP = User Data Protocol
- ❑ Need one component of each layer ⇒ Null components
- ❑ Nth layer control info is passed as N-1th layer data.

## Protocol Data Unit (PDU)

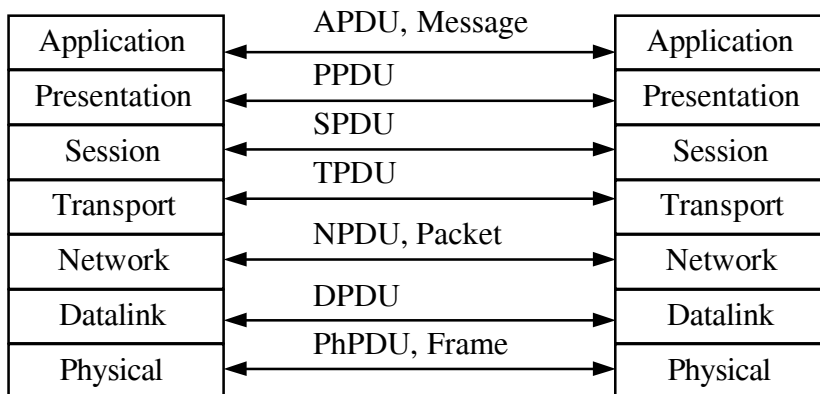

## Service Data Unit (SDU)

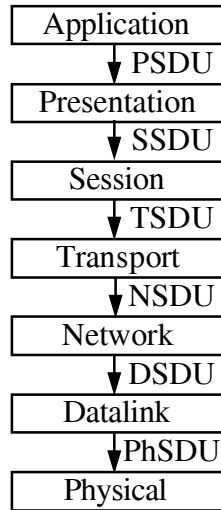

## TCP/IP Reference Model

- TCP = Transport Control Protocol
- IP = Internet Protocol (Routing)

Application	FTP	Telnet	HTTP	Application
Transport	TCP		UDP	Session
				Transport
Internetwork	IP			Network
Host to Network	Ethernet	Packet Radio	Point-to-Point	Datalink
				Physical

## ODN's Four-Layer Model

- ❑ ODN = Open Data Networks
- ❑ Bearer Service: Bit level transport service
  - ❑ Includes links, switches, routers, network management
- ❑ Transport Layer: Enhanced end-to-end services
  - ❑ May include reliable, sequenced delivery, flow control
  - ❑ Can be realize either in the network or in the end nodes
  - ❑ Not a core part of the bearer service
- ❑ Middleware: Common higher level functions
  - ❑ file system support, privacy, authentication, name service, directory service
- ❑ Applications: Email, Airline reservation

## Four Layer Model

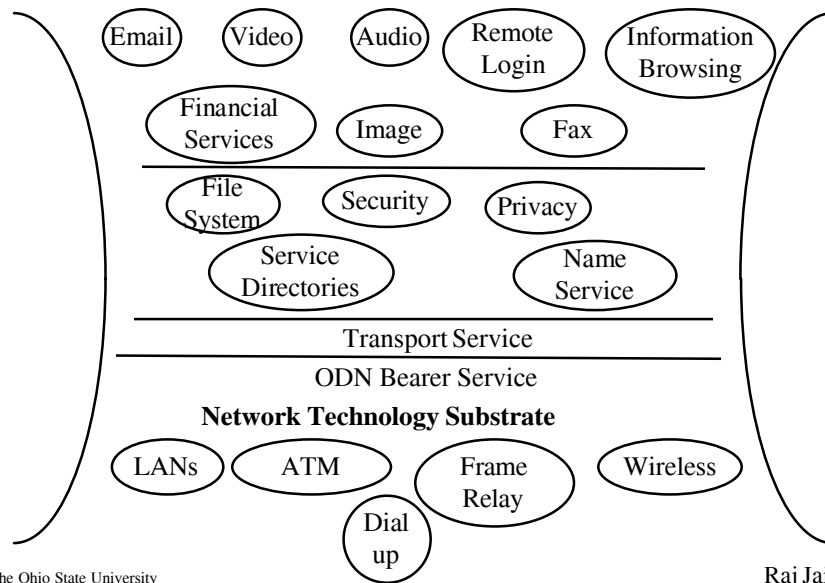

## Summary

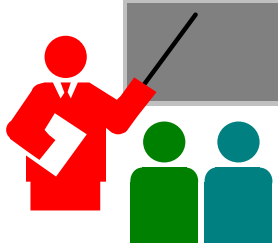

- Networking is growing exponentially
- Communication, Networks, and Distributed systems
- ISO/OSI's 7-layer reference model
- TCP/IP has a 4-layer model

## Reading Assignment

- Read Chapter 1 of Stallings, particularly
  - Table 1.2
  - Section 1.4, 1.5
- Optional: You may want to read ahead Chapter 2.