EE273 Lecture 6

Introduction to Signaling

January 28, 2004

Heinz Blennemann
Stanford University

Today's Assignment

- Problem Set 4
 - on Web & handout
- Reading
 - Sections 7.4 and 7.5
 - Complete before class on Monday
- Midterm
 - evening of Wed 2/11, 7-9PM
 - local SITN students must come to Stanford for the exam
 - we will have class on 2/13

A Quick Overview

- Introduction to Signaling
- transmission method
 - current vs. voltage
 - bipolar vs. unipolar
- termination scheme
 - parallel, source, both, unterminated
- references
 - 0 reference, transmitter reference, receiver reference
- source termination
 - use reflection to double signal amplitude
- differential signaling
 - 1.3-1.8x as many pins but many nice properties



Main Idea

- A good signaling system isolates the signal from noise rather than trying to overpower the noise
 - crosstalk - terminate both ends, use homogeneous media
 - ISI - matched terminations, no resonators, rise-time control
 - Power supply noise – avoid coupling into signal or reference
 - current mode, stable reference, differential signaling
 - Reference noise - bipolar signaling, differential signaling

An Example Signaling System

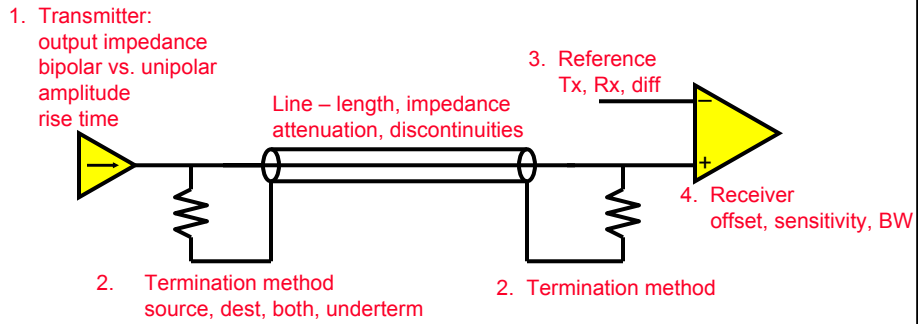

Transmission Mode (Output Impedance)

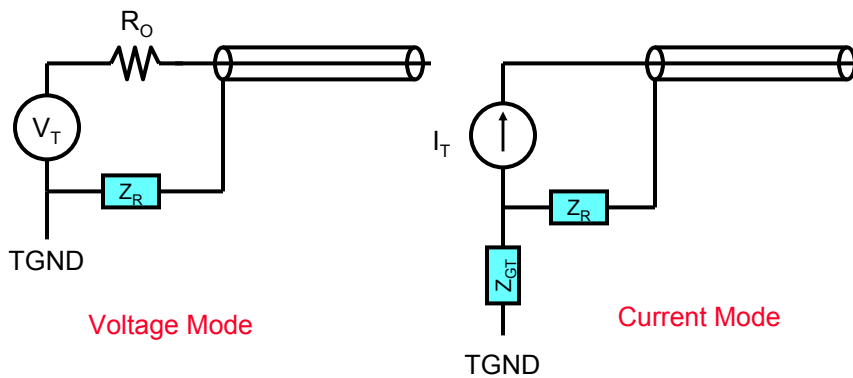

Voltage Mode vs. Current Mode

- In reality a continuum as R_O varies from 0 to ∞ .
- Both launch the same signal into the line

$$V_i = I_i Z_0$$

- Main differences are
 - ease of generation
 - much easier to generate a small current than a small voltage
 - especially with bipolar signaling
 - coupling of supply noise
 - coupling of return noise

Output Resistance and Signal Return Crosstalk

- Solve for signal return crosstalk using superposition
 - voltage source V_a active, all others shorted
 - How much current goes down other lines?
 - Other lines are in parallel with Z_R
 - form a current divider

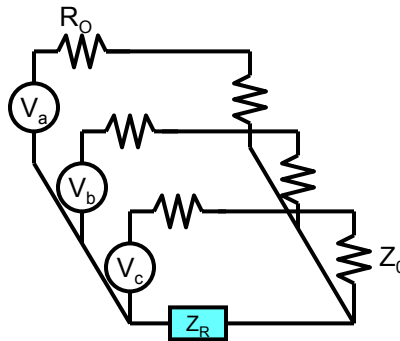

$$Z_X = Z_R \left\| \left(\frac{R_O + Z_0}{N-1} \right) \right.$$

$$= \frac{Z_R (R_O + Z_0)}{(N-1)Z_R + R_O + Z_0}$$

Signal Return Crosstalk (continued)

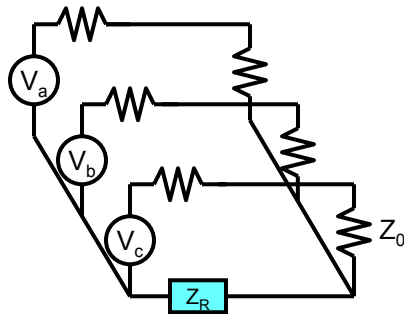

$$Z_X = Z_R \left\| \left(\frac{R_O + Z_0}{N-1} \right) \right.$$

$$= \frac{Z_R (R_O + Z_0)}{(N-1)Z_R + R_O + Z_0}$$

$$I_X = I_a \left(\frac{Z_X}{R_O + Z_0} \right)$$

$$= I_a \left(\frac{Z_R}{(N-1)Z_R + R_O + Z_0} \right)$$

$$k_{RX} = \left(\frac{Z_R}{(N-1)Z_R + R_O + Z_0} \right)$$

Signal Return Crosstalk (concluded)

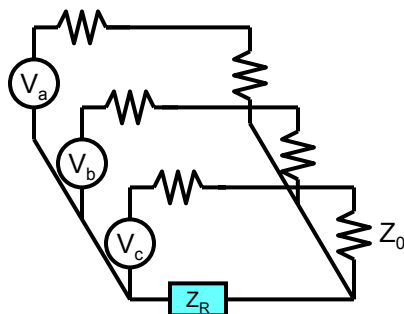

$$k_{RX} \leq \left(\frac{Z_R}{R_O + Z_0} \right)$$

- Since Z_R is usually $\ll R_O + Z_0$ we can approximate the formula with a simple ratio
- High output impedance reduces return crosstalk
 - Z_R/Z_0 for voltage mode $R=0$
 - $Z_R/2Z_0$ for matched $R=Z$
 - ∞ for current mode $R=\infty$
- Even with current mode signaling, however, it is advantageous to have a source termination: $R_O=Z_0$
 - But terminate to far side of return impedance

Source Terminated Current Mode

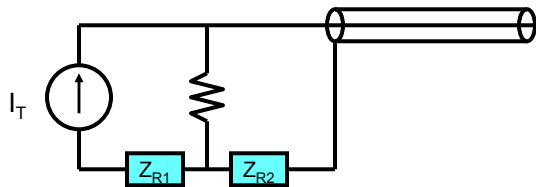

What is k_{RX} for this configuration?

Bipolar vs. Unipolar Signaling

- Unipolar signaling
 - logic 0 is 0 mA
 - logic 1 is $2x$ mA
- Bipolar signaling
 - logic 0 is $-x$ mA
 - logic 1 is x mA
 - gives balanced transmitter offsets
 - same for 0 and 1
 - allows the use of 0 as a receiver reference
- Same applies to voltage-mode x V rather than x mA
- Can use offset threshold for unipolar signaling - complicated

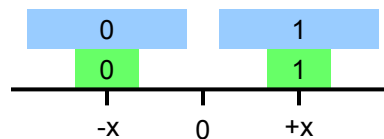
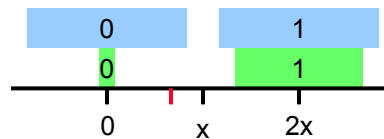

Threshold should be at midpoint of 'Tx excluded region', not midpoint of nominal values

A Typical Bipolar Current-Mode Driver

- Steers 5mA current between out+ and out-
 - constant draw from both current sources
- Relatively small devices
 - about $10\mu\text{m}/0.13\mu\text{m}$
 - termination is much bigger
- Use directly for differential signaling
- Tie out- to return for single-ended signaling
- Half the supply power of a unipolar driver with the same signal swing

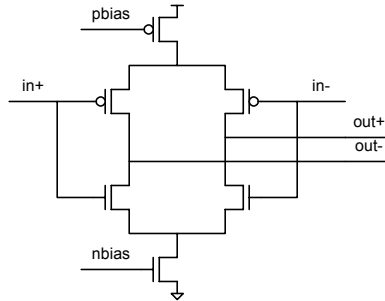

Model of Bipolar Current-Mode Driver

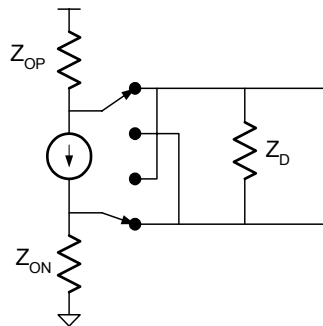
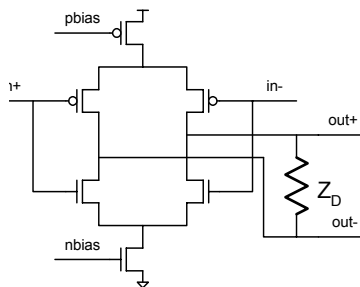

References

- Receiver compares received voltage or current to a *reference* to discriminate between symbols
- Errors in reference add directly to independent noise
- Several ways to generate a reference
 - use 0 (bipolar signaling)
 - derive from receiver power supply
 - send from transmitter

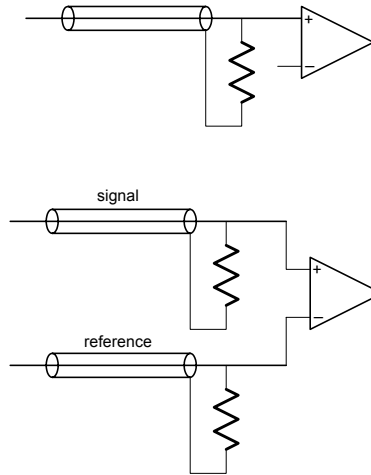

Source Termination (Without receiver termination)

- What is response at S and R to 10mA current step on source?
 - assume line and termination are both 50Ω
- What about a narrow current pulse?

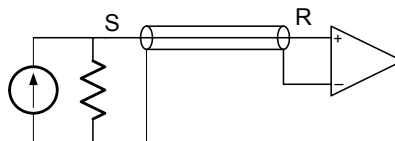

Source Termination Advantages and Disadvantages

- Power
 - current driver
 - half the power as terminating at both ends
 - voltage driver
 - half the power as parallel termination
 - no static power
- Cross talk
 - rejects near-end cross talk
 - but creates near-end cross talk at the far end of the line
- Proper waveform is observed only at receiver

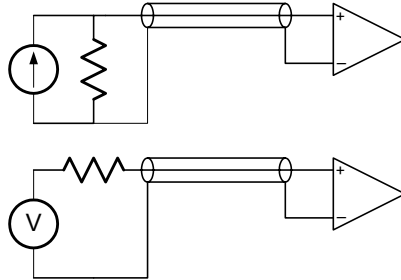

- More sensitive to inter-symbol interference
 - one bounce vs. Two

Source Termination The Bottom Line

- Little difference between terminating just at the source and just at the receiver
- Much better to terminate both ends of the line

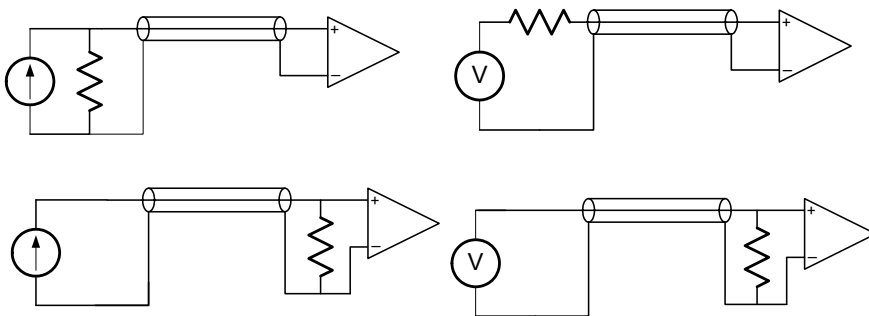

A Voltage-Mode Source Terminated Driver

- Looks like a simple driver, but...
 - Must digitally *trim* FETs to get $R_T = Z_0$ to an acceptable tolerance
 - Need a very low transmitter supply (250mV) to get an appropriate signal level
 - $\pm 125\text{mV}$ would be better
 - if transmit supply is generated with a switching regulator, very low power is possible

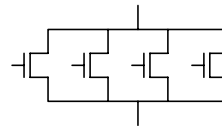
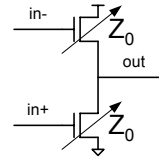

Underterminated Sources

- Conventional inverter drivers
 - have too high an output resistance (200Ω typical)
 - operate off of too high a supply voltage (2.5V typical)
- If the inverter tries to drive a line to full swing, it must *ring-up* the line resulting in large delay
- These inverters can be used as *underterminated* sources (high output impedance) to directly drive a 50Ω line with a low swing

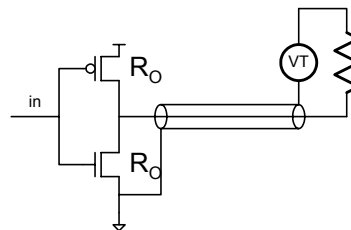

- Line is parallel terminated to mid-rail supply, V_T .
- What are the signal levels on the line?
- Why mid-rail terminate?

Differential Signaling

- A *differential* signal is sent as a difference in voltage or current between two lines
- Typically a positive signal is sent on one line and its complement on the other line
- This uses twice as many pins as *single-ended* signaling right?
 - wrong! 1.3-1.8x
 - differential signaling has a separate return for each signal
 - typically have 1 return for 2-8 signals

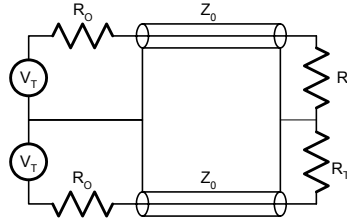

Advantages of Differential Signaling

- Signal serves as its own reference
 - compare positive signal to complement to detect
- Twice the signal swing
 - effective swing is A-B
- Noise immunity
 - many noise source become common mode
- Return current
 - becomes strictly DC
 - can be 0 for bipolar signaling

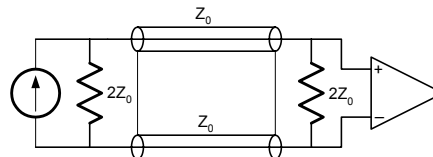
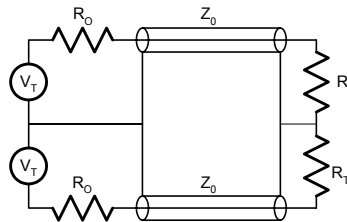

Differential Signaling and Balanced Transmission Lines

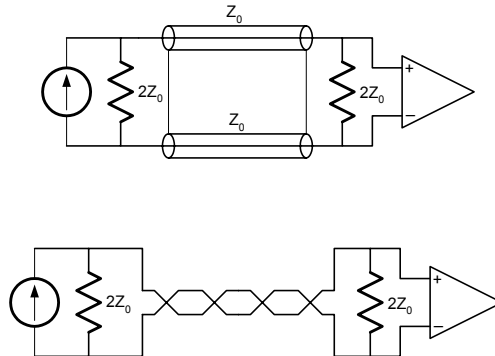

Next Time

- Signaling over lumped media
 - on-chip capacitive lines
 - off-chip LC circuits
- Signal encoding and Signal Amplitude
- Driving RC lines