EE273 Lecture 4 Noise in Digital Systems

January 21, 2004

Heinz Blennemann
Stanford University

Today's Assignment

- Problem set 3
 - on Web and handout
 - Due at start of class next Wednesday January 28
 - problem session on Friday January 23 11AM
- Reading
 - Sections 6.4 through 6.6
 - Complete before class on Monday January 26

Proportional and Independent Noise Sources

- Some noise is *proportional* to signal swing
 - crosstalk
 - inter-symbol interference
 - signal return noise
 - signaling power supply noise
 - if you increase the signal swing, you increase the noise
- Need to eliminate or cancel this noise
 - You can't overpower it!
- Some noise is independent of signal swing
 - receiver sensitivity
 - receiver offset
 - unrelated power supply noise
 - reference offsets
- Can eliminate or overpower this noise

EE273, L4, Jan 21, 2004

Copyright 2004 (C) by WJD & HCB, All Rights Reserved

5

Proportional and Independent Noise Sources

$$V_N = K_N V_S + V_{NI}$$

$$\frac{V_S}{2} \geq K_N V_S + V_{NI}$$

$$V_S \geq \frac{2V_{NI}}{(1 - 2K_N)}$$

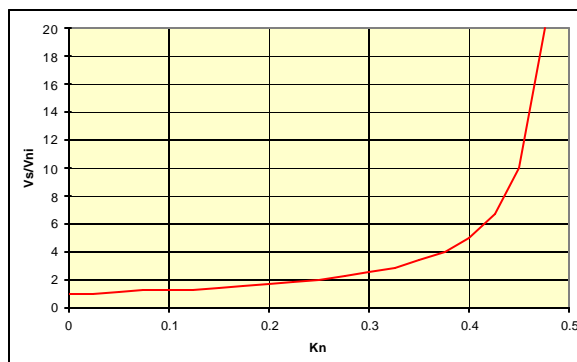

EE273, L4, Jan 21, 2004

Copyright 2004 (C) by WJD & HCB, All Rights Reserved

6

Bounded and Statistical Noise Sources

- Bounded noise sources
 - Bound total amplitude of noise via worst-case analysis
 - Noise guaranteed not to exceed this amount
 - Pessimistic but simple analysis
 - Examples
 - Crosstalk to adjacent lines (prop)
 - ISI (prop)
 - Receiver offset (fixed)
- Statistical noise sources
 - Approximate noise by a random process
 - Actual noise may really be random or may be deterministic
 - Noise amplitude characterized by RMS value
 - Can compute probability that noise will be less than margin
 - Examples
 - Johnson (thermal) noise (fixed)
 - Shot (quantization) noise
 - Crosstalk to large number of lines (prop)

EE273, L4, Jan 21, 2004

Copyright 2004 (C) by WJD & HCB, All Rights Reserved

7

Which sources are Proportional? Fixed? Which are Bounded? Statistical?

- 250mV differential signal
- 15% high-frequency attenuation
- 5% crosstalk from adjacent lines
- 5% ISI from reflections
- 20mV receiver offset+sensitivity
- 10mV RMS Gaussian noise
- What is the Bit Error Rate?

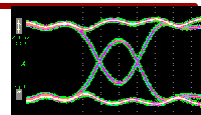

Signal Swing (dp-dn)		500
Gross Margin		250
Crosstalk	0.05	25
Reflections	0.05	25
Attenuation	0.15	75
KN	0.25	125
Receiver offset+sensitivity		20
Bounded noise		145
Net Margin		105
Gaussian Noise		10
VSNR		10.5
BER		1.15E-24

EE273, L4, Jan 21, 2004

Copyright 2004 (C) by WJD & HCB, All Rights Reserved

8

Power Supply Noise

- The power supply network has parasitic elements
 - on-chip: resistive
 - off-chip: inductive
- Current draw across these elements induces a noise voltage
 - $Ri + Ldi/dt$
- Instantaneous current is what matters
 - may be many times the DC current
 - 10W chip draws 4A at 2.5V
 - peak current may be 10-20A.

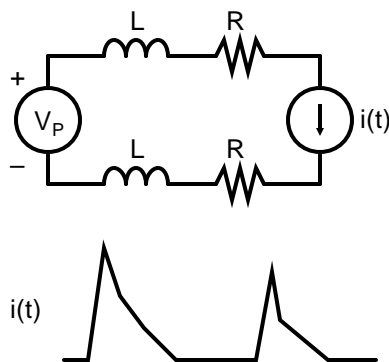

Types of Supply Noise

- Two types of loads
 - logic loads
 - signal loads
- Two types of noise
 - single-supply noise
 - differential-supply noise

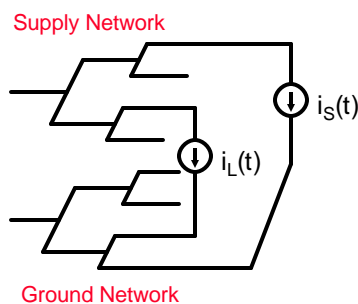

Single Supply Noise

- Voltage drops across parasitics cause variation in the voltage of a single supply (V_{DD} or GND) from one point in the system to another
- If a signal is referenced to the local supply, this variation is additive voltage noise
- The problem can be reduced by using an appropriate reference
 - reference to receiver supply
 - send an explicit reference

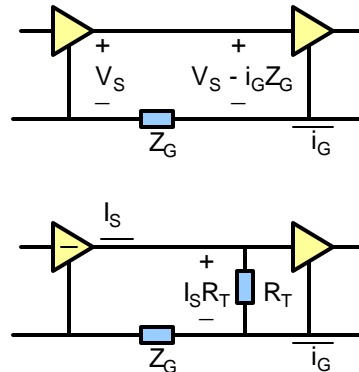

Differential Supply Noise

- Drops across supply parasitics cause the local supply voltage, V_{PL} , to vary over time
 - affects the delay of many elements
 - systems may not meet timing specifications
 - causes jitter in timing circuits

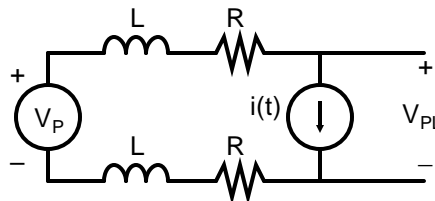

Cross Talk

- Noise induced by one signal that interferes with another signal
- Capacitive coupling between on-chip lines
- Capacitive *and* Inductive coupling between off-chip lines
- Coupling over shared signal returns

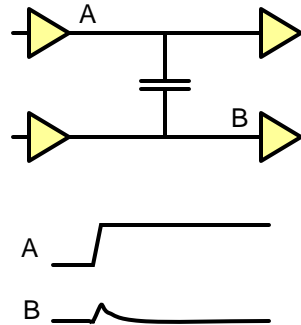

EE273, L4, Jan 21, 2004

Copyright 2004 (C) by WJD & HCB, All Rights Reserved

13

Cross Talk Between Capacitive Lines

- On-chip wires have significant capacitance to adjacent wires
 - on same layer
 - on adjacent layers
- When adjacent signals change, voltage on a floating line is disturbed
 - capacitive voltage divider
 - signal is not restored

$$k_{2c} = \frac{2C_c}{2C_c + C_o}$$

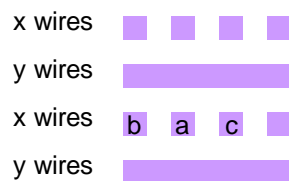

a is victim, b and c are aggressors

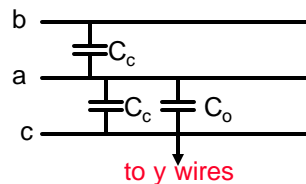

EE273, L4, Jan 21, 2004

Copyright 2004 (C) by WJD & HCB, All Rights Reserved

14

Capacitive Lines with Drive

- If victim line, a, is driven, a will be disturbed but then restored with time constant $\tau=R(C_c+C_o)$
- If rise on aggressor, b, is slow compared to τ , magnitude of disturbance is reduced

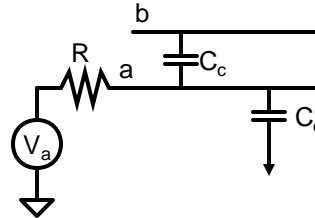

$$\left(\frac{t}{t_r}\right)\left(1 - \exp\left(-\frac{t_r}{t}\right)\right)$$

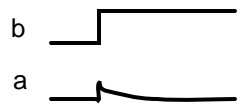

$$\tau=R(C_c+C_o)$$

Cross Talk and Delay

- Capacitive cross talk can affect delay of RC signals
- If aggressor(s) switch in opposite direction, effective capacitance of C_c is doubled
- If aggressor(s) switch in the same direction, C_c is effectively eliminated
- Can cause 2:1 variation in delay in some cases
- Significant cause of jitter if timing is critical

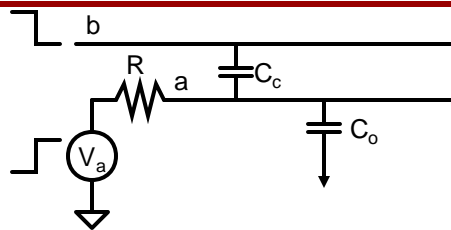

Transmission Line Cross Talk

- A signal transition on one transmission line induces forward and reverse traveling waves on adjacent transmission lines

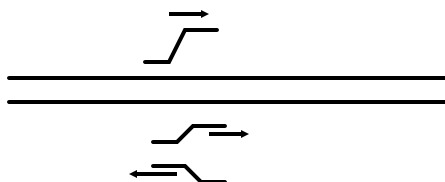

EE273, L4, Jan 21, 2004

Copyright 2004 (C) by WJD & HCB, All Rights Reserved

17

Transmission Line Cross Talk Experiment

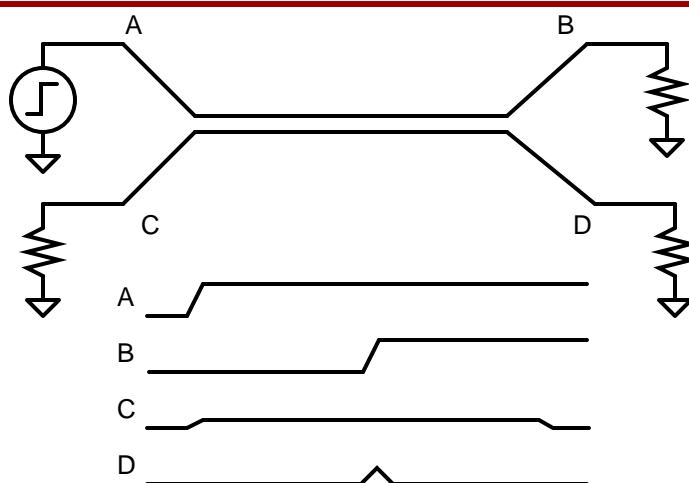

EE273, L4, Jan 21, 2004

Copyright 2004 (C) by WJD & HCB, All Rights Reserved

18

Experimental Cross Talk Measurements

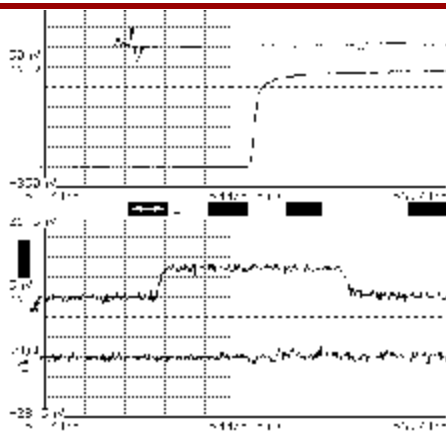

EE273, L4, Jan 21, 2004

Copyright 2004 (C) by WJD & HCB, All Rights Reserved

19

Inductive and Capacitive Coupling

- Consider a positive transient on aggressor line, A
- Capacitive coupling induces a *voltage* on victim line B
 - positive waves in both forward and reverse directions
- Inductive coupling induces a *current* in line B
 - positive wave in the reverse direction
 - negative wave in the forward direction

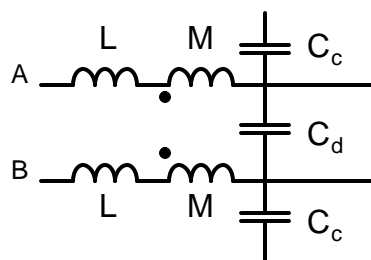

$$k_{lx} = \frac{M}{L}$$

$$k_{cx} = \frac{C_d}{C}$$

EE273, L4, Jan 21, 2004

Copyright 2004 (C) by WJD & HCB, All Rights Reserved

20

Near-end and Far-end Crosstalk

- Inductive and capacitive coupling *add* at the **near** end of the line
 - both waves are positive
 - pulse begins at beginning of coupled section
 - pulse width equals length of coupled section
- Inductive and capacitive coupling *subtract* at the **far** end of the line
 - in a homogeneous medium cancellation is exact
 - narrow pulse coincident with wave on aggressor

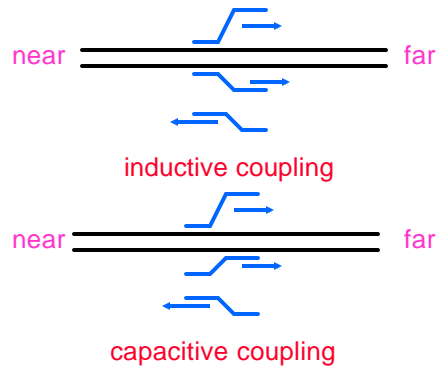

EE273, L4, Jan 21, 2004

Copyright 2004 (C) by WJD & HCB, All Rights Reserved

21

Near End and Far End Crosstalk The Equations

$$k_{rx} = \frac{k_{cx} + k_{lx}}{4}$$

$$k_{fx} = \frac{k_{cx} - k_{lx}}{2}$$

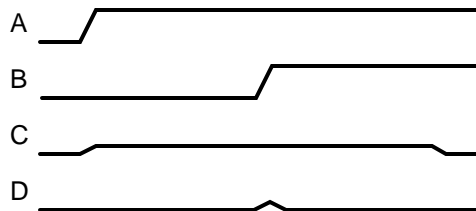

EE273, L4, Jan 21, 2004

Copyright 2004 (C) by WJD & HCB, All Rights Reserved

22

Crosstalk and Termination

- The noise resulting from crosstalk depends on the termination
- E.g., if $k_{fx} = 0$ and $k_{rx} = 0.1$ compare termination at both ends to termination at receiver only
 - Both ends: near end crosstalk absorbed by source termination, little or no contribution to noise at destination
 - $k_{Nrx} = k_{rx}k_r$
 - Receiver only: near end crosstalk reflects from source and adds directly to noise at receiver
 - $k_{Nrx} = k_{rx}$
- What happens with termination only at source?

EE273, L4, Jan 21, 2004

Copyright 2004 (C) by WJD & HCB, All Rights Reserved

23

Crosstalk and Termination

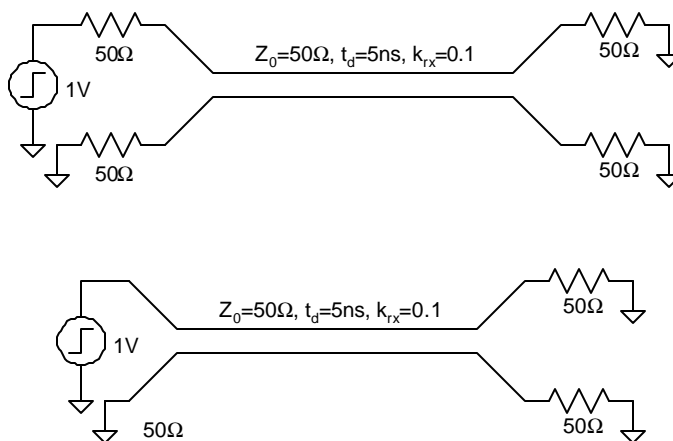

EE273, L4, Jan 21, 2004

Copyright 2004 (C) by WJD & HCB, All Rights Reserved

24

Next Time

- Signal return crosstalk
- Intersymbol interference
- Managing noise