

E-Mail Security

Raj Jain
Washington University in Saint Louis
Saint Louis, MO 63130
Jain@cse.wustl.edu

Audio/Video recordings of this lecture are available at:

<http://www.cse.wustl.edu/~jain/cse571-07/>



- ❑ Email Overview: SMTP, POP, IMAP, Radix-64, MIME
- ❑ Security Services: Privacy, authentication, Integrity, Non-Repudiation, Anonymity
- ❑ Secure Email Standards: S/MIME, PGP, DKIM, ...
- ❑ Spam

Internet Email Overview

- ❑ **Simple Mail Transfer Protocol (SMTP):**
Protocol to deposit email in another user's mailbox
Was originally designed for 7-bit ASCII text messages
- ❑ **Post Office Protocol (PoP):**
Protocol to retrieve email from your mailbox
Authenticates the user
- ❑ **Internet Mail Access Protocol (IMAP)**
- ❑ **Multimedia Internet Mail Encoding (MIME):**
To encode non-text messages

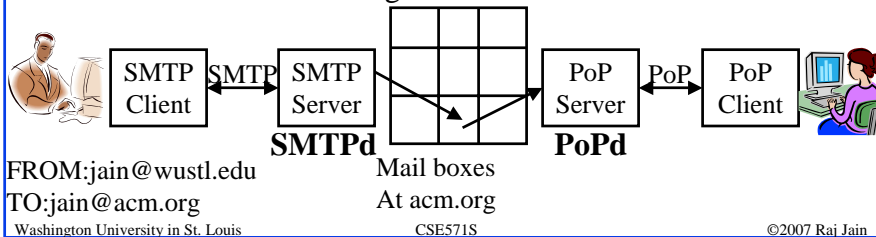

16-3

SMTP

- ❑ Defined in RFC 2821 and RFC 2822
- ❑ Clients connect to port 25 of SMTP server
- ❑ It is a push protocol and does not allow to pull
- ❑ Extended SMTP (ESMTP) is defined in RFC 2821
- ❑ ESMTP uses EHLO in stead of HELO
- ❑ ESMTP allows finding the maximum message size
- ❑ SMTP-AUTH is an authentication extension to SMTP (RFC 4954)
- ❑ Allows only authorized users to send email

Radix-64 Encoding

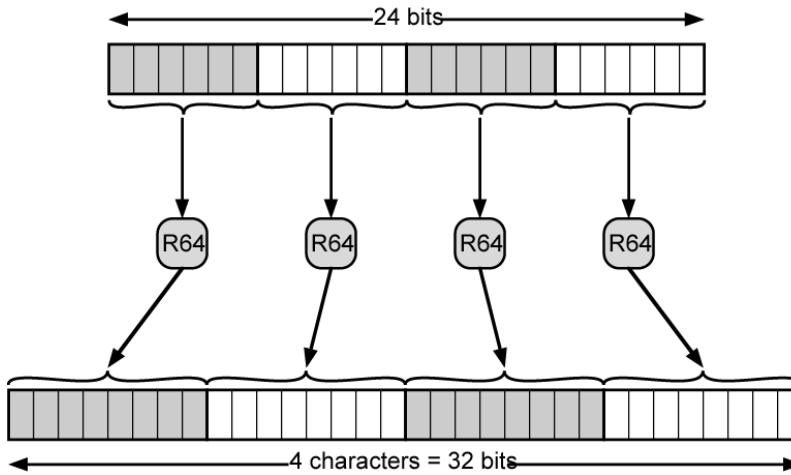

MIME Example

```
--unique-boundary-1
Content-Type: multipart/parallel;
boundary=unique-boundary-2

--unique-boundary-2
Content-Type: audio/basic
Content-Transfer-Encoding: base64

... base64-encoded 8000 Hz single-channel
u-law-format audio data goes here....

--unique-boundary-2
Content-Type: image/gif
Content-Transfer-Encoding: Base64
... base64-encoded image data goes here....
```

Security Services for E-Mail

- Privacy: of content
- Authentication: of Sender
- Integrity: of Content
- Non-repudiation: Sender cannot deny
- Proof of Submission: Proof of sending
(Certified mail) – MTA can sign a message digest
- Proof of Delivery: to recipient
(return receipt + Content non-repudiation)
- Message flow confidentiality
- Anonymity

Security Services for E-Mail (Cont)

- Containment: Keeping messages in a security zone
- Audit: event log
- Accounting: Accounting log
- Self Destruct: Receiving mail program will destroy the message
- Message Sequence Integrity: in-order delivery

Establishing Keys

- ❑ 1-to-1
- ❑ Public Keys:
 - Need public key to send an encrypted message
 - Can sign a message and send a certificate
- ❑ Secret Keys:
 - Via KDC

Privacy

- ❑ Employee vs. Employer
- ❑ End-to-End Privacy
- ❑ Use public key to encrypt a secret key
- ❑ Same encrypted message can be sent to multiple recipients
- ❑ Distribution lists require trusting the exploder

Source Authentication

- ❑ Sign a hash of the message with private key
(Good for distribution lists also)
- ❑ Secret Key:
 - MAC=CBC residue with secret key
 - Message digest of the secret key
 - Message digest is encrypted with the secret key
(Same digest for multiple recipients)
 - Can share a secret key with mail exploder

Message Integrity

- ❑ Generally goes with source authentication
Integrity with source anonymity is meaningless
- ❑ You can use a shared secret
- ❑ Anyone can change the message encrypted or
protected with public key

Non-Repudiation

- ❑ Public Key:
 - Non-Repudiation: sender signs the message with private key
 - Plausible Deniability: Sender computes a MAC using a random key S and sends $[[S]_{\text{Bob Public}}]_{\text{Alice Private}}$
- ❑ Secret Key:
 - Non-Repudiation: Notary N . N and recipient share a secret
 - N computes a seal = digest of the message and alice's name using a secret key
 - N shares a secret key with recipient and sends A MAC of the message, seal, and Alice.
 - A judge could ask N to verify if the seal is valid.

Proof of Delivery

- ❑ Delivering MTA or recipient can sign a message digest
- ❑ Impossible to prove that recipient got the message.
 - If recipient signs it before getting the last part of the message, it may not get complete message but has signed.
 - If recipient signs after getting the last part of the message, it may not sign but has the message.

Verifying Posting Date

- ❑ Preventing Backdating: Notary signs and dates the message
- ❑ Preventing Postdating: Notary signs and dates the message along with a fact not known before the date, e.g., newspaper headline, lottery number, ...

Digital Postmarks

- ❑ Post office can date stamp your document
(Service available in USA and other countries also)
- ❑ Client software signs a document and sends it to DPM service
- ❑ DPM authenticates the signature, generates a timestamp and signs the resulting package (hash of message, signature, time)
- ❑ The DPM receipt is sent to the client software and also stored in a non-repudiation database with the message and signature
- ❑ The client software wraps the original document and DPM receipt
- ❑ Anyone can verify the signature and time
- ❑ Original document can be requested from DPM service database
- ❑ www.usps.com/electronicpostmark/

Anonymity

- ❑ penet.fi allowed two-way communication.
Assigned code name to sender.
- ❑ If someone replies they are also assigned a code name
 - Assigned code name to the source exploder of the replies.
- ❑ Message Flow Confidentiality
 - Can send random messages through third party
 - Can use several intermediaries

Anonymous Remailers

- ❑ Pseudonymous Remailers: Give a pseudonym to the sender and send.
- ❑ Keep a log of pseudonym and actual address => Can be disclosed
- ❑ Cypherpunk Remailers: Removes the senders address (no return address) => No log
- ❑ Mixmaster Remailers: Anonymous remailer that sends messages in fixed size packets and reorders them to prevent tracing
- ❑ Mixminion Remailers: Strongest anonymity. Handle replies, forward anonymity, replay prevention, key rotation, exit policies, integrated directory servers, dummy traffic

Secure Email Standards

- ❑ Privacy Enhanced Mail (PEM) - Not deployed
- ❑ S/MIME - Uses PEM principles
- ❑ PGP
- ❑ STARTTLS (SMTP over TLS – RFC 2487)
- ❑ SMTP-AUTH (SMTP with password authentication)
- ❑ DKIM

S/MIME

- ❑ Secure MIME
- ❑ Originally developed by RSA Data Security Inc.
- ❑ Later control passed on to IETF
- ❑ Can use any certificate
- ❑ Bob first sends a signed message with a certificate
- ❑ Alice can then send an encrypted message to Bob
- ❑ PEM and S/MIME use X.500 names
- ❑ S/MIME requires Email as "Alternate Name" in the X.509 certificate
- ❑ Also, a new component E was added to the X.500 name

S/MIME Example

```
-----boundarymarker
Content-Type: application/pkcs7-signature;
  name="smime.p7s"
Content-Transfer-Encoding: base64
Content-Disposition: attachment; filename="smime.p7s"
Content-Description: S/MIME Cryptographic Signature
ABDECDIPAQaAIHGNPAISJPDSFPSDNADNPA
-----boundarymarker
```

Pretty Good Privacy (PGP)

- Used RSA and IDEA (RSA patent in US until 2000)
- V2.6.2 became legal for use within US and can be downloaded from MIT
- A patent-free version using public algorithm has also been developed
- Code published as an OCRable book
- Open PGP and GNU Privacy Guard
- Uses certificates issued by almost anyone
- Certificates can be registered on public sites, e.g., MIT
- hushmail.com is an example of pgp mail service

DomainKeys Identified Mail (DKIM)

- ❑ RFC 4871
- ❑ Sending MTA inserts a signature on behalf of the sender
- ❑ Verifying (Receiving) MTA verifies the signature based on public key of the sender

Spam Statistics

- ❑ 30 Billion spams per day (June 2005) to 90 billion spams per day (feb 2007)
- ❑ 80 to 85% of mail is spam
- ❑ Most spam originates from USA (19.6%) but 73.58% of spamvertisers are in China.
- ❑ Addresses are harvested from web pages, usenet groups, corporate directories
- ❑ Spam is sent using botnets, open relays, and open proxies
- ❑ Many DNS blackhole list sites were closed down due to DDoS attacks

CAN-SPAM Act of 2003

- Spamming is a misdemeanor
- You can send unsolicited commercial email iff
 1. Unsubscribe compliance
 - Unsubscribe mechanism
 - Opt-out honored within 10 days
 - Opt-out lists used only for compliance
 2. Content compliance
 - Accurate from, subject, advertisers address
 - Identify Adult content
 3. Sending behavior Compliance
 - Not sent through an open relay
 - Not sent to harvested address
 - Cannot contain false header

Anti-SPAM:End-User Techniques

- Address munging: jain at wustl dot edu
- Avoid responding to spam
- Use contact forms
- Disable HTML in e-mail: Web bugs (1x1 transparent gifs) can identify who read the mail
- Disposable e-mail addresses
- Reporting spam: spam@uce.gov
- Responding to spam: Overload the advertiser

Anti-SPAM: Administrator Techniques

- Authentication and Reputation
- Challenge/Response Systems
- Checksum-based filtering: Matching checksum => Spam, hash busters
- Country-based filtering
- DNS Black Lists
- Enforcing RFC standards
- HELO/EHLO checking: HELO 127.0.0.1 or HELO localhost
- Greylisting: Error code 4xx => Retry later
- Fake MX Records: Multiple MX records, spammers do not retry
- Greeting delay: Spammers do not wait

Administrator Techniques (Cont)

- Hybrid filtering: Pattern matching and scoring
- Rule-based filtering: more general filtering and scoring
- Statistical content filtering: Learning from user submitted spam/ham
- Reverse DNS checks: Email address domain=IP address domain?
- Sender-supported whitelists and tags: Certified not be spammer
- SMTP callback verification: Check return address

Anti-SPAM: Sender ISP Techniques

- Background checks on new users and customers
- Confirmed opt-in for mailing list: Removes false submission
- Egress spam filtering: Check customer's email addresses
- Limit e-mail backscatter: bouncing messages
- Port 25 blocking
- Port 25 interception: Rate limit and egress spam filter
- Rate limiting
- Monitor Spam reports
- Strong Acceptable Use Policy

Anti-SPAM: Law Enforcement

- Honeypots
- Spamtraps

Summary

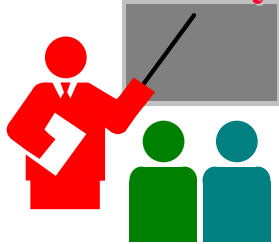

- ❑ UA, MTA, SMTP, PoP, IMAP, Radix-64, MIME
- ❑ Encryption is done using secret keys, which are sent using public key encryption
- ❑ S/MIME and PGP both use certificates
- ❑ Spam identification/reduction requires recipient, administrators, ISPs, and government actions

Homework 16

- ❑ Read chapter 20 complete, and relevant sections of 21, 22 of the textbook
- ❑ Try answering Exercise 20.4 and 20.7