

Quality of Service In Data Networks

Raj Jain
The Ohio State University
Columbus, OH 43210
Jain@CIS.Ohio-State.Edu

These slides are available on-line at
<http://www.cis.ohio-state.edu/~jain/cis788-99/>

Raj Jain



- ❑ ATM QoS and Issues
- ❑ Integrated services/RSVP and Issues
- ❑ Differentiated Services and Issues
- ❑ QoS using MPLS
- ❑ End-to-end QoS

QoS Components

① Signaling
and Admission control



② Shaping

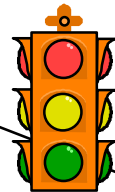

③ Policing

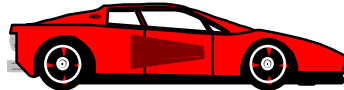
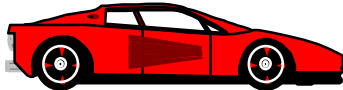

Scheduling ⑤

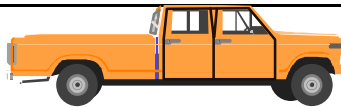

④ Routing

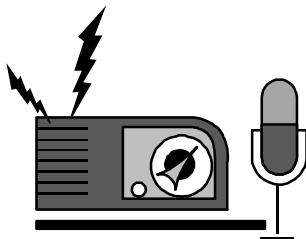
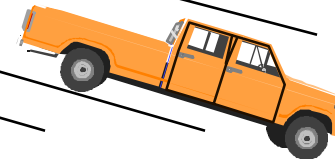
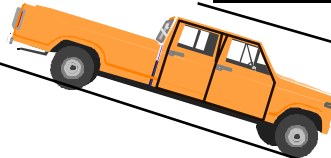

⑦ Traffic Monitoring
and feedback

⑥ Buffer Mgmt

ATM QoS: Issues

- ❑ Can't easily specify QoS: What is the CDV required for a movie?
- ❑ Signaling too complex \Rightarrow Need Lightweight Signaling
- ❑ Need priority or weight among VCs to map DiffServ and 802.1D
- ❑ Need Group Address
- ❑ Need Heterogeneous Point-to-Multipoint: Variegated VCs
- ❑ Can't easily aggregate QoS: $VP = \Sigma VCs$
- ❑ Need QoS Renegotiation

Integrated Services

1. **Best Effort Service:** Like UBR.
 2. **Controlled-Load Service:** Performance as good as in an unloaded datagram network. No quantitative assurances. Like nrt-VBR or UBR w MCR
 3. **Guaranteed Service:** rt-VBR
 - Firm bound on data throughput and delay.
 - Like CBR or rt-VBR
- Need a signaling protocol: RSVP
 - Design philosophy similar to ATM
 - Per-flow
 - End-to-end
 - Signaling

Problems with IntServ+RSVP

- ❑ Complexity in routers: classification, scheduling
- ❑ Not scalable with # of flows
⇒ Not suitable for backbone.
- ❑ Need a concept of “Virtual Paths” or aggregated flow groups for the backbone.
- ❑ Need policy controls: Who can make reservations?
⇒ RSVP admission policy (rap) working group.
- ❑ Receiver Based:
Need sender control/notifications in some cases.
- ❑ Soft State: Need route/path pinning (stability).
- ❑ No negotiation and backtracking
- ❑ Note: RSVP is being revived for MPLS and DiffServ

Raj Jain

Trend: Differentiation Not Integration

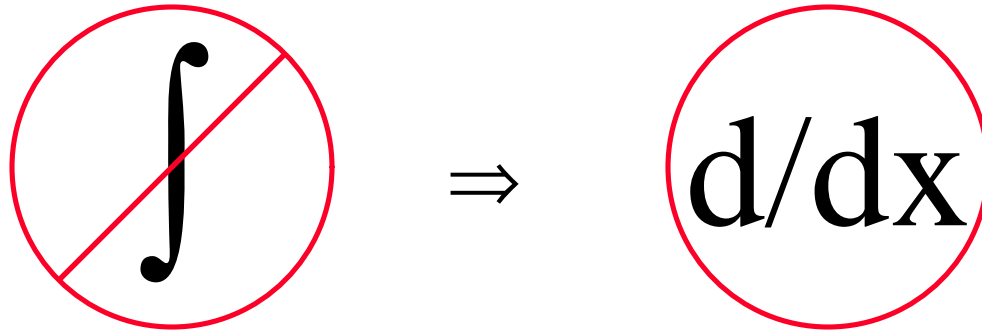

- DiffServ to standardize IPv4 ToS byte's first six bits
- Packets gets marked at network ingress
Marking \Rightarrow treatment (behavior) in rest of the net
Six bits \Rightarrow 64 different per-hop behaviors (PHB)



DiffServ (Cont)

- ❑ Per-hop behavior = % of link bandwidth, Priority
- ❑ Services: End-to-end. Voice, Video, ...
 - Transport: Delivery, Express Delivery, ...
Best effort, controlled load, guaranteed service
- ❑ DS group will not develop services
They will standardize “Per-Hop Behaviors”
- ❑ Marking based on static “Service Level Agreements” (SLAs). Avoid signaling.

Expedited Forwarding

- ❑ Also known as “Premium Service”
- ❑ Virtual leased line
- ❑ Similar to CBR
- ❑ Guaranteed minimum service rate
- ❑ Policed: Arrival rate $<$ Minimum Service Rate
- ❑ Not affected by other data PHBs
 - ⇒ Highest data priority (if priority queueing)
- ❑ Code point: 101 110

Assured Forwarding

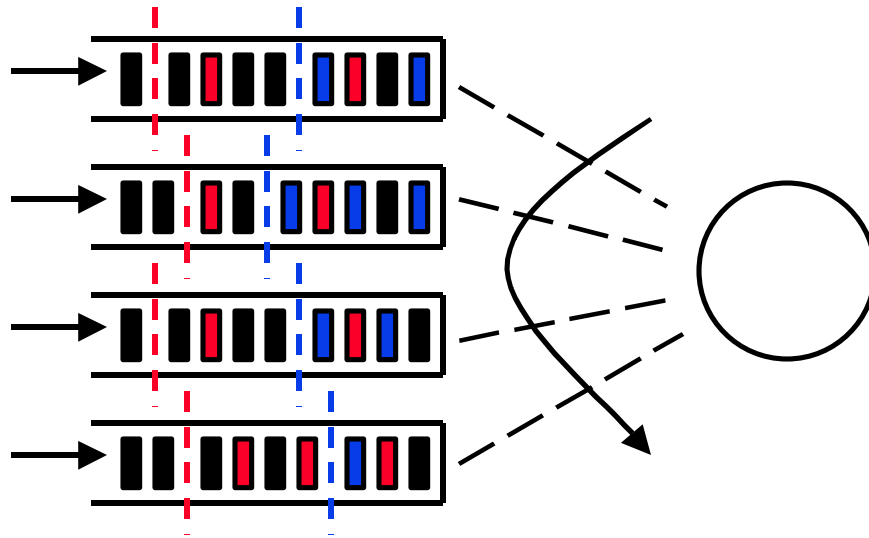

- ❑ PHB Group
- ❑ Four Classes: No particular ordering
- ❑ Three drop preference per class

Assured Forwarding (Cont)

- ❑ DS nodes SHOULD implement all 4 classes and MUST accept all 3 drop preferences. Can implement 2 drop preferences.
- ❑ Similar to nrt-VBR/ABR/GFR
- ❑ Code Points:

Drop Prec.	Class 1	Class 2	Class 3	Class 4
Low	010 000	011 000	100 000	101 000
Medium	010 010	011 010	100 010	101 010
High	010 100	011 100	100 100	101 100

- ❑ Avoids 11x000 (used for network control)

Problems with DiffServ

- ❑ End-to-end $\neq \Sigma$ per-Hop
Designing end-to-end services with weighted guarantees at individual hops is difficult.
Only Expedited Forwarding will work.
- ❑ Designed for static Service Level Agreements (SLAs)
Both the network topology and traffic are highly dynamic.
- ❑ How to ensure resource availability inside the network?
- ❑ DiffServ is unidirectional \Rightarrow No receiver control

DiffServ Problems (Cont)

- QoS is for the aggregate not micro-flows.
Not intended/useful for end users. Only ISPs.
 - Large number of short flows are better handled by aggregates.
 - Long flows (voice and video sessions) need per-flow guarantees.
 - High-bandwidth flows (1 Mbps video) need per-flow guarantees.
- ⇒ DiffServ alone is not sufficient for backbone.
Signaling via RSVP will be required.

MPLS Mechanisms for QoS

- ❑ Explicit Routing: Multiple label switched paths (LSPs) can be used in parallel to the same egress.
- ❑ Signaling, Admission Control, Routing: Each LSP can have priority, preemption, policing, overbooking
- ❑ Constrained based routing of LSPs
Allows both Traffic constraints and Resource Constraints (Resource Attributes)
- ❑ Hierarchical division of the problem (Label Stacks)
- ❑ Danger: Too much too soon...again

Bandwidth Broker

- ❑ Repository of policy database. Includes authentication
- ❑ Users request bandwidth from BB
- ❑ BB sends authorizations to leaf/border routers
Tells what to mark.
- ❑ Ideally, need to account for bandwidth usage along the path
- ❑ BB allocates only boundary or bottleneck

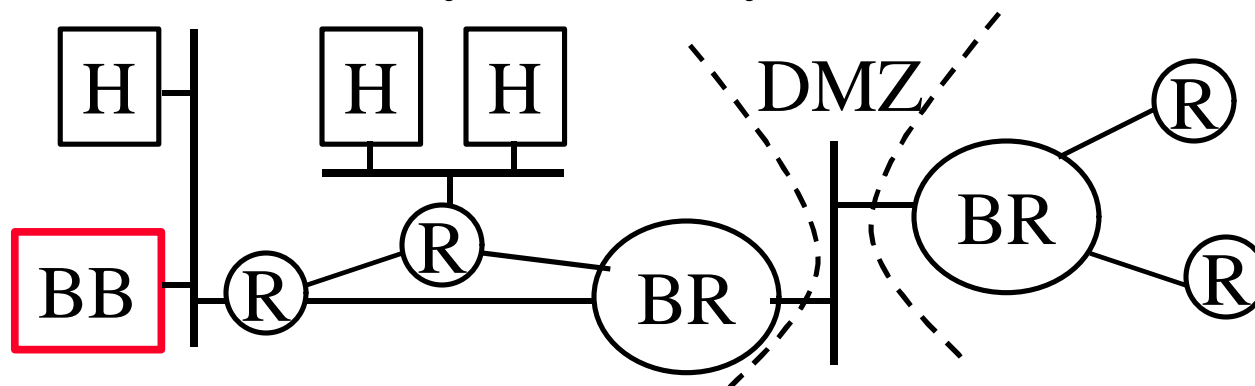

IEEE 802.1D Model

- ❑ Massive bandwidth. Simple priorities will do.
- ❑ **Up to eight priorities:** Strict.
 - 1 Background
 - 2 Spare
 - 0 Best Effort**
 - 3 Excellent Effort
 - 4 Control load
 - 5 Video (Less than 100 ms latency and jitter)
 - 6 Voice (Less than 10 ms latency and jitter)
 - 7 Network Control

End-to-end View

- ❑ ATM/PPP backbone, Switched LANs/PPP in Stub
- ❑ IntServ/RSVP, 802.1D, MPLS in Stub networks
- ❑ DiffServ, ATM, MPLS in the core

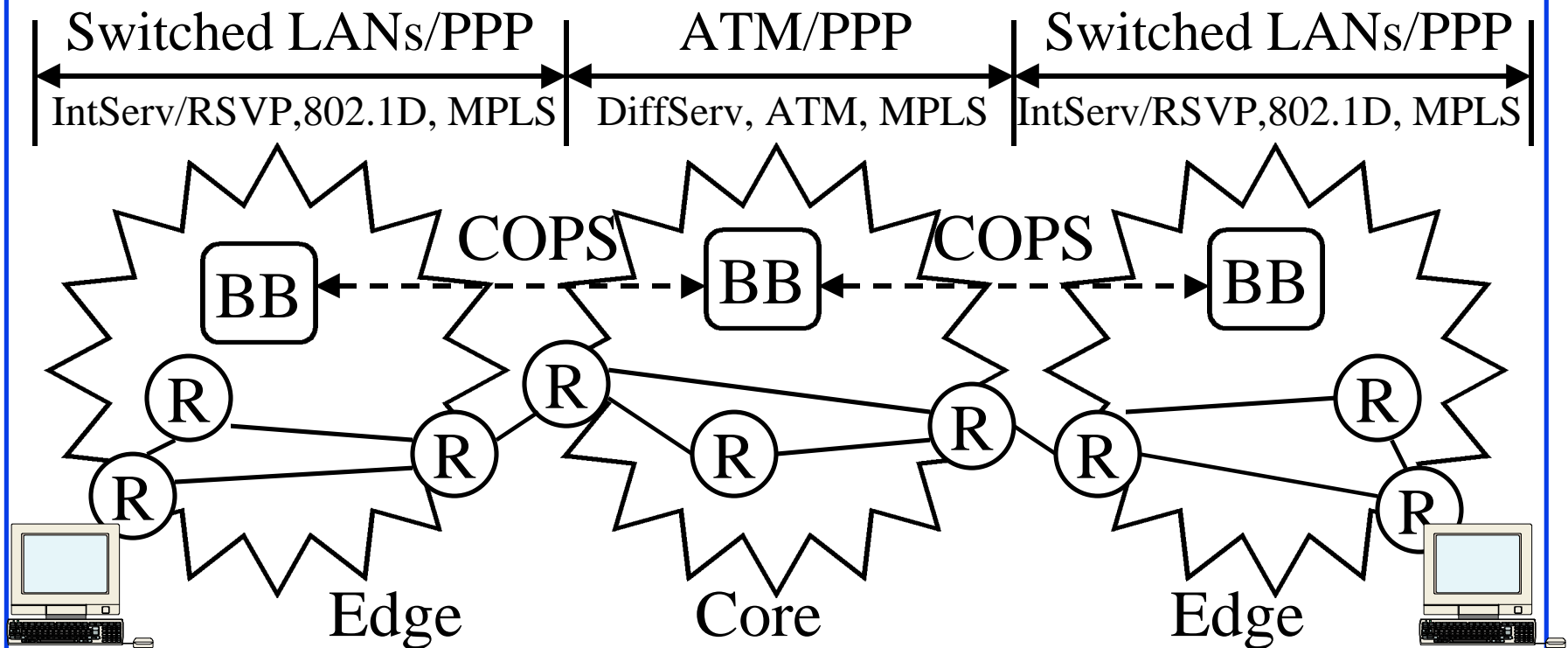

Raj Jain

Additional Mechanisms

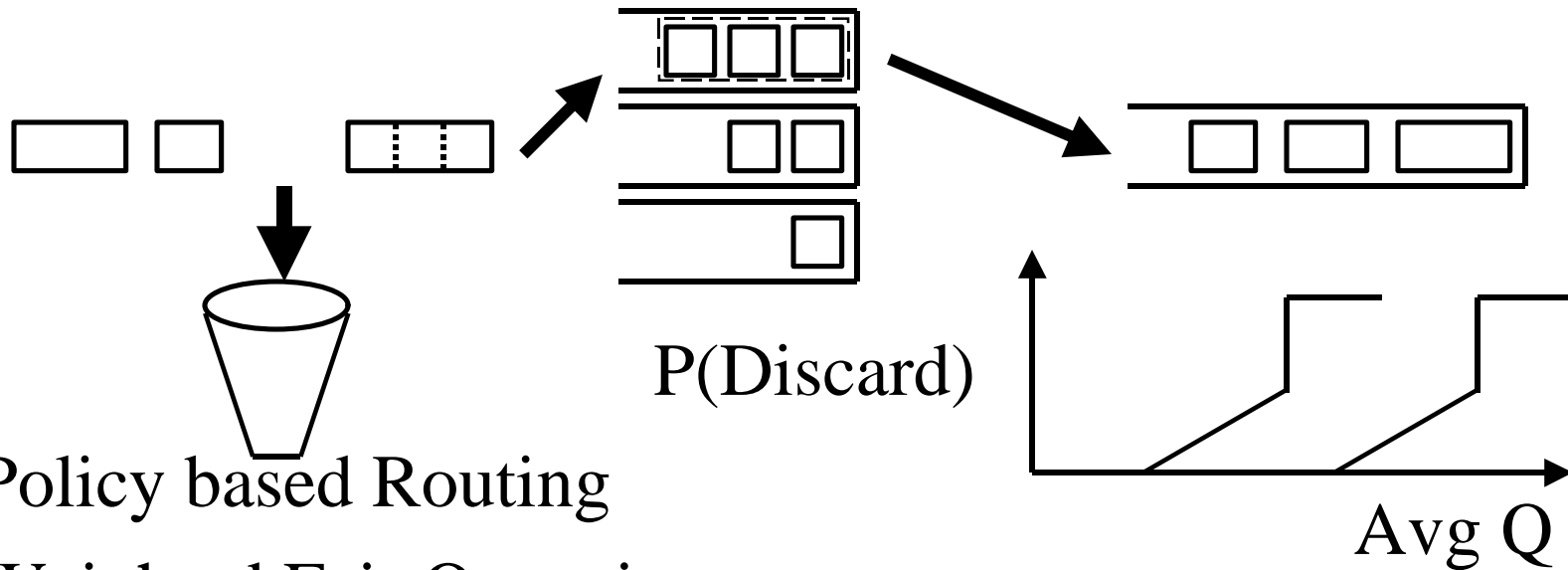

- ❑ Policy based Routing
- ❑ Weighted Fair Queueing
- ❑ Weighted Random Early Detection
- ❑ Link Fragmentation and Interleaving
- ❑ These internal mechanisms do not require standardization

Summary

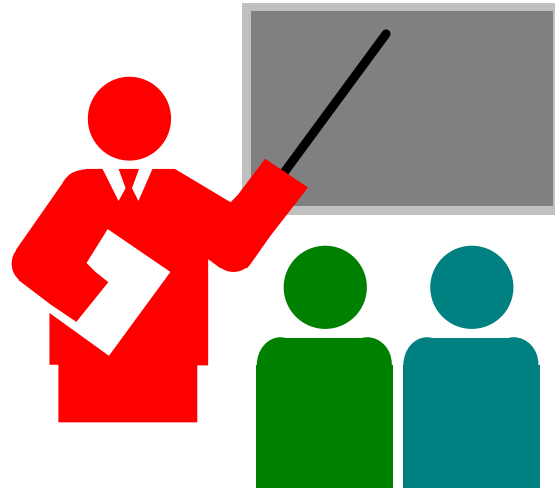

- ❑ ATM: CBR, VBR, ABR, UBR, GFR
- ❑ Integrated Services: GS = rtVBR, CLS = nrt-VBR
- ❑ Signaling protocol: RSVP
- ❑ Differentiated Services will use the DS byte
- ❑ MPLS allows traffic engineering and is most promising
- ❑ 802.1D allows priority

Raj Jain

References

- ❑ For a detailed list of references see:
[refs/ipqs_ref.htm](http://www.cis.ohio-state.edu/~jain/cis788-97/ipqs_ref.htm)
- ❑ Integrated Services Overview, http://www.cis.ohio-state.edu/~jain/cis788-97/integrated_services/index.htm
- ❑ Multimedia over IP (RSVP, RTP, RTCP, RTSP),
http://www.cis.ohio-state.edu/~jain/cis788-97/ip_multimedia/index.htm
- ❑ Additional papers and presentations on QoS are at:
<http://www.cis.ohio-state.edu/~jain/>